



THURLBY THANDAR INSTRUMENTS

TG1000 & TG2000

DDS Function Generators

INSTRUCTION MANUAL



Table of Contents

Introduction	2
Specifications	3
Safety	6
EMC	8
Installation	9
Connections	10
Front Panel Connections	10
Rear Panel Connections	11
General	12
Initial Operation	12
Standard Waveform Operation	15
Setting Generator Parameters	15
AUX Output	18
Warnings and Error Messages	19
Sweep Operation	20
General	20
Setting Sweep Parameters	20
Gated Mode	25
Tone Mode	26
FSK	27
Modulation	28
System Operations from the Utility Menu	29
Calibration	31
Equipment Required	31
Calibration Procedure	31
Calibration Routine	32
Remote Calibration	33
Remote Operation	34
USB Interface	38
Remote Commands	39
Maintenance	42
Appendix 1. Warning and Error Messages	43
Appendix 2. Factory System Defaults	44

Note: The latest revisions of this manual, device drivers and software tools can be downloaded from: <http://tti1.co.uk/downloads/manuals-generator.htm>

This manual is 48591-1020 Issue 7

Introduction

This manual is for both the TG2000 and TG1000 function generators. The TG1000 has a maximum frequency of 10MHz and no remote control capability but is otherwise functionally the same as the TG2000 20MHz generator. Wherever there are differences in the specification or operation, the limits for the TG1000 are shown in square brackets [] after the TG2000 limits.

This function generator uses direct digital synthesis to provide high performance and extensive facilities at a breakthrough price. It can generate a variety of waveforms between 1mHz and 20MHz [10MHz] with a resolution of 6 digits and an accuracy better than 10ppm.

Direct digital synthesis for accuracy & stability

Direct digital synthesis (DDS) is a technique for generating waveforms digitally using a phase accumulator, a look-up table and a DAC. The accuracy and stability of the resulting waveforms is related to that of the crystal master clock.

The DDS generator offers not only exceptional accuracy and stability but also high spectral purity, low phase noise and excellent frequency agility.

A wide range of waveforms

High quality sine, square and pulse waveforms can be generated over the full frequency range of 1mHz to 20MHz [10MHz].

Triangle waveforms can also be generated but with limitations as to the maximum usable frequency.

Variable symmetry/duty-cycle is available for squarewave and pulse waveforms.

Sweep

All waveforms can be swept from 0.2Hz to their maximum frequency in a single sweep at a rate variable between 50 milliseconds and 999 seconds. The sweep is fully phase continuous.

Sweep can be linear or logarithmic, single or continuous. Single sweeps can be triggered from the front panel, the trigger input, or the digital interfaces. A sweep marker is provided.

AM

External Amplitude Modulation is available for all waveforms.

FSK and Tone modes

Frequency Shift Keying provides phase coherent switching between two selected frequencies; in Tone mode the output is stepped asynchronously through a user-defined list of up to 16 frequencies. In both modes the switching source can be the internal trigger generator, front panel, an external signal or a remote command.

Easy and convenient to use

All of the main generator parameters are clearly displayed together on a backlit LCD with 4 rows of 20 characters. Sub menus are used to set the parameters for each function.

All parameters can be entered directly from the numeric keypad. Alternatively most parameters can be incremented or decremented using the rotary encoder.

This system combines quick numeric data entry with quasi-analogue adjustment when required.

Fully programmable via USB and Addressable RS-232 (TG2000 only)

The generator has both USB and RS-232 interfaces which can be used for remote control of all of the instrument functions.

As well as operating in conventional single instrument mode the RS-232 serial interface can also be used in addressable mode whereby up to 32 units can be linked to a single PC serial port.

Specifications

Specifications apply at 18°- 28°C after one hour warm-up, at maximum output into 50Ω. TG1000 limits, where different, are shown in square brackets [] after the TG2000 limits.

WAVEFORMS

Standard waveforms of sine, square, triangle, DC, positive pulse and negative pulse.

Sine

Range:	1mHz to 20MHz [10MHz]
Resolution:	1mHz or 6 digits
Accuracy:	10 ppm for 1 year; ± 1mHz below 0.2Hz
Temperature Stability:	Typically <1 ppm/°C outside 18° to 28°C
Output Level:	2.5mV to 10Vp-p into 50Ω
Harmonic Distortion:	<0.3% THD to 20kHz (typically 0.1%) <-45dBc to 300kHz <-35dBc to 20MHz [10MHz] (typically <-40dBc)
Non-harmonic Spuri:	<-55dBc to 1MHz, <-55dBc + 6dB/octave 1MHz to 20MHz [10MHz]

Square

Range:	1mHz to 20MHz [10MHz]
Resolution:	1mHz or 6 digits
Symmetry Control:	20% to 80% (1% resolution) 1mHz to 20MHz [10MHz]
Accuracy:	10 ppm for 1 year; ± 1mHz below 0.2Hz
Output Level:	2.5mV to 10Vp-p into 50Ω
Rise and Fall Times:	<22ns
Aberrations:	<5% + 2mV

Triangle

Range:	1mHz to 1 MHz
Resolution:	1mHz or 6 digits
Accuracy:	10 ppm for 1 year; ± 1mHz below 0.2Hz
Output Level:	2.5mV to 10Vp-p into 50Ω
Linearity Error:	<0.5% to 100 kHz

Positive and Negative Pulses

Range:	1mHz to 20MHz [10MHz]
Resolution:	1mHz or 6 digits
Symmetry Control:	20% to 80% (1% resolution) 1mHz to 10MHz
Accuracy:	10 ppm for 1 year; ± 1mHz below 0.2Hz
Output Level:	1.25mV to 5Vp-p into 50Ω positive or negative only pulses, with respect to the DC Offset baseline.
Rise and Fall Times:	<22ns
Aberrations:	<5% + 2mV

OPERATING MODES

Continuous

Continuous cycles of the selected waveform are output at the programmed frequency.

Gated

Non-phase coherent gating - output carrier wave is on while Gate signal is high and off while low.

Carrier frequency:	From 1mHz to 20MHz [10MHz].
Carrier waveforms:	All
Trigger rep. rate:	DC to 100 kHz external; to 5kHz using internal trigger generator.
Gate signal source:	Manual (front panel MAN TRIG key), external signal (TRIG/GATE IN), internal gate generator or remote interface.

Sweep

Carrier Waveforms:	All
Sweep Mode:	Linear or logarithmic, single or continuous.
Sweep Width:	From 0.2Hz to 20MHz [10MHz] in one range. Phase continuous. Independent setting of the start and stop frequency.
Sweep Time:	50ms to 999s (3 digit resolution).
Marker:	Available from AUX output. Variable during sweep.
Sweep Trigger Source:	The sweep may be free run or triggered from any of the following sources: Manual (front panel MAN TRIG key), external from TRIG/GATE IN or from remote interface.

External Amplitude Modulation

Carrier Frequency:	From 1mHz to 20MHz [10MHz].
Carrier Waveforms:	All
Modulation Source:	VCA IN socket

Frequency Shift Keying (FSK)

Phase coherent switching between two selected frequencies at a rate defined by the switching signal source.

Carrier frequency:	From 1Hz to 20MHz [10MHz].
Carrier waveforms:	All
Switch repetition rate:	DC to 5kHz (internal trigger) or DC to 1MHz (external trigger).
Switching signal source:	Manual (front panel MAN TRIG key), internal trigger generator, external signal (TRIG/GATE IN) or remote interface.

Tone

The tone is output while the trigger signal is high and stopped while the trigger signal is low. The next tone is output when the trigger signal is high again.

Carrier Waveforms:	All
Frequency List:	Up to 16 frequencies from 1Hz to 20MHz [10MHz]
Switching Source:	Manual (front panel MAN TRIG key), internal trigger generator, external signal (TRIG/GATE IN) or remote interface.
Min Switching Time:	1ms per tone

OUTPUTS

Main Output

Output Impedance:	50Ω or 600Ω
Amplitude:	5mV to 20V pk-pk open circuit, (2.5mV to 10V pk-pk into 50Ω/600Ω). Output can be specified as HiZ (open circuit value) or V (voltage into characteristic impedance) in pk-pk, r.m.s. or dBm.
Amplitude Accuracy:	±3% ±1mV at 1kHz into 50Ω/600Ω.
Amplitude Flatness:	±0.2dB to 500kHz; ±2dB to 20MHz [±1dB to 10MHz].

DC Offset Range:	±10V. DC offset plus signal peak limited to ±10V from 50Ω/600Ω.
DC Offset Accuracy:	typically ±3% ±10mV, unattenuated.
Resolution:	3 digits for both Amplitude and DC Offset.
Pulse Aberrations:	<5% + 2mV.

Aux Out

Multifunction output user definable or automatically selected to be any of the following:

Waveform Sync:	A square wave at the main waveform frequency. Symmetry is 50% for sine and triangle waves at MAIN OUT; for square waves and pulses symmetry is the same as that of the waveform at MAIN OUT.
Trigger:	Outputs a replica of the current trigger signal.
Sweep Sync:	Outputs a trigger signal at the start of sweep to synchronize an oscilloscope. Can additionally output a sweep marker.
Output Signal Level:	Output impedance 50Ω nominal. Logic levels of <0.8V & >3V, except for Sweep Sync. Sweep Sync is a 3-level waveform: low at start of sweep, high for the duration of the last frequency step at end of sweep, with a narrow 1V pulse at the marker point.

INPUTS

Ext Trig /Gate

Frequency Range:	DC - 1MHz for FSK; DC – 100kHz for Gate; DC – 2.5kHz for Tone and Sweep.
Signal Range:	Threshold nominally TTL level; maximum input ±10V.
Minimum Pulse Width:	100ns for Gate and FSK modes; 0.2ms for Sweep and Tone modes.
Input Impedance:	10kΩ

VCA In

Frequency Range:	DC - 100kHz.
Signal Range:	2.5V for 100% level change at maximum output.
Input Impedance:	typically 6kΩ.

INTERFACES (TG2000 only)

RS-232:	Variable Baud rate, 19200 Baud maximum. 9-pin D-connector. As well as operating in a conventional RS-232 mode the interface can be operated in addressable mode whereby up to 32 instruments can be addressed from one RS-232 port.
USB:	Standard USB hardware connection.

GENERAL

Display:	20 character x 4 row alphanumeric LCD.
Data Entry:	Keyboard selection of mode, waveform etc.; value entry direct by numeric keys or by rotary control.
Stored Settings:	Up to 9 complete instrument set-ups may be stored and recalled from non-volatile memory.
Size:	260(W) x 88(H) x 235(D)
Weight:	2kg. (4.5lb.)
Power:	110-120V AC or 220V-240V AC ±10%, 50/60Hz, adjustable internally; 35VA max. Installation Category II.
Operating Range:	+5°C to 40°C, 20-80% RH.
Storage Range:	-20°C to + 60°C.
Environmental:	Indoor use at altitudes up to 2000m, Pollution Degree 2.
Safety & EMC:	Complies with EN61010-1 & EN61326.

Safety

This generator is a Safety Class I instrument according to IEC classification and has been designed to meet the requirements of EN61010–1 (Safety Requirements for Electrical Equipment for Measurement, Control and Laboratory Use). It is an Installation Category II instrument intended for operation from a normal single phase supply.

This instrument has been tested in accordance with EN61010–1 and has been supplied in a safe condition. This instruction manual contains some information and warnings which have to be followed by the user to ensure safe operation and to retain the instrument in a safe condition.

This instrument has been designed for indoor use in a Pollution Degree 2 environment in the temperature range 5°C to 40°C, 20% – 80% RH (non–condensing). It may occasionally be subjected to temperatures between +5° and –10°C without degradation of its safety. Do not operate while condensation is present.

Use of this instrument in a manner not specified by these instructions may impair the safety protection provided. Do not operate the instrument outside its rated supply voltages or environmental range.

WARNING! THIS INSTRUMENT MUST BE EARTHED

Any interruption of the mains earth conductor inside or outside the instrument will make the instrument dangerous. Intentional interruption is prohibited. The protective action must not be negated by the use of an extension cord without a protective conductor.

When the instrument is connected to its supply, terminals may be live and opening the covers or removal of parts (except those to which access can be gained by hand) is likely to expose live parts. The apparatus shall be disconnected from all voltage sources before it is opened for any adjustment, replacement, maintenance or repair.

Any adjustment, maintenance and repair of the opened instrument under voltage shall be avoided as far as possible and, if inevitable, shall be carried out only by a skilled person who is aware of the hazard involved.

If the instrument is clearly defective, has been subject to mechanical damage, excessive moisture or chemical corrosion the safety protection may be impaired and the apparatus should be withdrawn from use and returned for checking and repair.

Make sure that only fuses with the required rated current and of the specified type are used for replacement. The use of makeshift fuses and the short–circuiting of fuse holders is prohibited.

Do not wet the instrument when cleaning it and in particular use only a soft dry cloth to clean the LCD window.

The following symbols are used on the instrument and in this manual:–



Caution –refer to the accompanying documentation, incorrect operation may damage the instrument.



terminal connected to chassis ground.



mains supply OFF.



mains supply ON.



alternating current.

EC Declaration of Conformity

We Thurlby Thandar Instruments Ltd
Glebe Road
Huntingdon
Cambridgeshire PE29 7DR
England

declare that the

TG1000 & TG2000 DDS Function Generators

meet the intent of the EMC Directive 2004/108/EC and the Low Voltage Directive 2006/95/EC. Compliance was demonstrated by conformance to the following specifications which have been listed in the Official Journal of the European Communities.

EMC

Emissions:

- a) EN61326-1 (2006) Radiated, Class B
- b) EN61326-1 (2006) Conducted, Class B
- c) EN61326-1 (2006) Harmonics, referring to EN61000-3-2 (2006)

Immunity:

EN61326-1 (2006) Immunity Table 1, referring to:

- a) EN61000-4-2 (1995) Electrostatic Discharge
- b) EN61000-4-3 (2006) Electromagnetic Field
- c) EN61000-4-11 (2004) Voltage Interrupt
- d) EN61000-4-4 (2004) Fast Transient
- e) EN61000-4-5 (2006) Surge
- f) EN61000-4-6 (2007) Conducted RF

Performance levels achieved are detailed in the user manual.

Safety

EN61010-1 Installation Category II, Pollution Degree 2.



CHRIS WILDING
TECHNICAL DIRECTOR
2 March 2010

This instrument has been designed to meet the requirements of the EMC Directive 2004/108/EC. Compliance was demonstrated by meeting the test limits of the following standards:

Emissions

EN61326-1 (2006) EMC product standard for Electrical Equipment for Measurement, Control and Laboratory Use. Test limits used were:

- a) Radiated: Class B
- b) Conducted: Class B
- c) Harmonics: EN61000-3-2 (2006) Class A; the instrument is Class A by product category.

Immunity

EN61326-1 (2006) EMC product standard for Electrical Equipment for Measurement, Control and Laboratory Use.

Test methods, limits and performance achieved are shown below (requirement shown in brackets):

- a) EN61000-4-2 (1995) Electrostatic Discharge : 4kV air, 4kV contact, Performance A (B).
- b) EN61000-4-3 (2006) Electromagnetic Field:
3V/m, 80% AM at 1kHz, 80MHz – 1GHz: Performance A (A) and 1.4GHz to 2GHz:
Performance A (A); 1V/m, 2.0GHz to 2.7GHz: Performance A (A).
- c) EN61000-4-11 (2004) Voltage Interrupt: ½ cycle and 1 cycle, 0%: Performance A (B);
25 cycles, 70%: Performance A (C); 250 cycles, 0%: Performance B (C).
- d) EN61000-4-4 (2004) Fast Transient, 1kV peak (AC line only; signal connections <3m,
therefore not tested), Performance A (B).
- e) EN61000-4-5 (2006) Surge, 0-5kV (line to line), 1kV (line to ground), Performance A (B).
- f) EN61000-4-6 (2007) Conducted RF, 3V, 80% AM at 1kHz (AC line only; signal
connections <3m, therefore not tested), Performance A (A).

According to EN61326 the definitions of performance criteria are:

Performance criterion A: 'During test normal performance within the specification limits.'

Performance criterion B: 'During test, temporary degradation, or loss of function or performance which is self-recovering'.

Performance criterion C: 'During test, temporary degradation, or loss of function or performance which requires operator intervention or system reset occurs.'

Cautions

To ensure continued compliance with the EMC directive the following precautions should be observed:

- a) connect the generator to other equipment using only high quality, double-screened cables. For the purposes of EMC testing it is assumed that signal connections from the instrument will be <3m and therefore immunity tests for signal lines (Fast Transient and Conducted RF) have been omitted.
- b) after opening the case for any reason ensure that all signal and ground connections are remade correctly before replacing the cover. Always ensure all case screws are correctly refitted and tightened.
- c) In the event of part replacement becoming necessary, only use components of an identical type, see the Service Manual.

Mains Operating Voltage

Check that the instrument operating voltage marked on the rear panel is suitable for the local supply. Should it be necessary to change the operating voltage, proceed as follows:

- 1) Disconnect the instrument from all voltage sources.
- 2) Unclip the front bezel by gently pulling the centre of each long edge up and forward.
The case halves are held together by 4 plastic push-rivets. Use the blade of a small screwdriver in the slot beside each rivet to first ease out the rivet head and then fully remove the rivet body. Separate the case halves. Visit www.tti-test.com for further details.
- 3) Remove the screws securing the pcb to the case lower and lift out the pcb with front and rear panels attached; lift one side of the pcb at a time, with the case pcb clips on that side pulled clear of the pcb edge.
- 4) Change the voltage settings by changing the soldered links beside the transformer:
For 230V operation fit link LK2 only
For 115V operation fit links LK1 and LK3 only
- 5) Reassemble in the reverse order.
- 6) To comply with safety standard requirements the operating voltage marked on the rear panel must be changed to clearly show the new voltage setting.
- 7) Change the fuse to suit the new operating voltage, see below.

Fuse

Ensure that the correct mains fuse is fitted for the set operating voltage. The correct mains fuse types are:

for 230V operation:	250 mA (T) 250V HRC
for 100V or 115V operation:	500 mA (T) 250V HRC

The use of makeshift fuses or the short-circuiting of the fuse holder is prohibited.

Mains Lead

Connect the instrument to the AC supply using the mains lead provided. Should a mains plug be required for a different mains outlet socket, a suitably rated and approved mains lead set should be used which is fitted with the required wall plug and an IEC60320 C13 connector for the instrument end. To determine the minimum current rating of the lead-set for the intended AC supply, refer to the power rating information on the equipment or in the Specification.

WARNING! THIS INSTRUMENT MUST BE EARTHED.

Any interruption of the mains earth conductor inside or outside the instrument will make the instrument dangerous. Intentional interruption is prohibited.

Front Panel Connections

MAIN OUT

This is the output from the main generator; output source impedance can be set to 50Ω or 600Ω. It will provide up to 20V peak-to-peak e.m.f. which will yield 10V peak-to-peak into a matched load. To maintain waveform integrity only 50Ω cable should be used and the receiving end should be terminated with a 50Ω load. It can tolerate a short circuit for 60 seconds.



Do not apply external voltages to these outputs.

AUX OUT

This is a TTL/CMOS level output which may be set to any of the following signals from the **AUX OUT** screen.

waveform sync	A sync signal phase coincident with the MAIN OUT waveform. For sine and triangle waves the sync waveform rising edge is at the 0° phase point of MAIN OUT and the falling edge is at the 180° phase point. For square waves and pulses both phase and symmetry are coincident with MAIN OUT.
Trigger	Provides a replica version of the actual trigger signal; internal, external, manual and remote all produce a trigger sync.
Sweep sync	Goes low at the start of sweep and high at the last frequency step of the sweep. In addition, a 1/4-amplitude marker pulse can be output at a specified marker frequency.

AUX OUT logic levels are nominally 0V and 5V from typically 50Ω. AUX OUT will withstand a short circuit.



Do not apply external voltage to this output.

TRIG/GATE IN

This is the external input for Trigger, Gate and Sweep operations.



Do not apply external voltages exceeding ±10V.

VCA IN

This is the input socket for external amplitude modulation.



Do not apply external voltages exceeding ±10V.

Rear Panel Connections (TG2000 only)

RS-232

9-pin D-connector compatible with addressable RS-232 use. The pin connections are shown below:

Pin	Name	Description
1	–	No internal Connection
2	TXD	Transmitted data from instrument
3	RXD	Received data to instrument
4	–	No internal connection
5	GND	Signal ground
6	–	No internal connection
7	RXD2	Secondary received data
8	TXD2	Secondary transmitted data
9	GND	Signal ground

Pin 2, 3 and 5 may be used as a conventional RS-232 interface with XON/XOFF handshaking. Pins 7, 8 and 9 are additionally used when the instrument is used in addressable RS-232 mode. Signal grounds are connected to instrument ground. The RS-232 address is set from the **remote** menu on the **UTILITY** screen, see System Operations section.

USB

The USB port accepts a standard USB cable. The Windows plug-and-play functions should automatically recognise that the instrument has been connected.

Initial Operation

This section is a general introduction to the organisation of the instrument and is intended to be read before using the generator for the first time. Detailed operation is covered in later sections starting with Standard Waveform Operation.

In this manual front panel keys and sockets are shown in capitals, e.g. STATUS, AUX OUT; all soft-key labels, entry fields and messages displayed on the LCD are shown in a different type-font, e.g. **WAVEFORM**, **sine**.

DDS Principles

In this instrument waveforms are generated by Direct Digital Synthesis (DDS). A phase accumulator is incremented at a rate proportional to the required output frequency. The most significant 12 bits of the accumulator are used to address a look-up table ROM that converts the phase information into sinewave amplitude data; this data is then passed to a 10-bit Digital-to-Analogue Converter (DAC) which produces the output waveform. For triangle waves the ROM look-up table is by-passed and the phase accumulator output is passed directly to the DAC.

At low frequencies all 4096 points in the output wave are stepped through, but as the frequency increases points are progressively missed out. Sinewaves and triangles are subsequently filtered to smooth the steps in the DAC output; this technique ensures good sinewave purity up to the maximum frequency of the generator but the practical limit to which excellent triangle linearity is maintained is only about 100kHz. Squarewaves and pulses are derived from the sinewave using a variable threshold comparator; this permits symmetry control of these waveforms across the whole instrument frequency range.

The major advantages of DDS over conventional analogue generation are:

- Frequency accuracy and stability is that of the crystal oscillator.
- Frequencies can be set with high resolution from mHz to MHz.
- Low phase noise and distortion.
- Very wide frequency sweeps are possible.
- Fast phase continuous frequency switching.
- In addition, being a digital technique, it is easier to make every parameter programmable from the keyboard, or remotely via the USB or RS-232 interfaces.

Switching On

Switch on the generator using the ON/OFF switch on the rear panel. To fully disconnect from the AC supply unplug the mains cord from the back of the instrument or switch off at the AC supply outlet; make sure that the means of disconnection is readily accessible. Disconnect from the AC supply when not in use.

At power up the generator displays the installed software revision and conducts a self-test. Power-on self-test takes a few seconds, after which the status screen is displayed, showing the generator parameters set to their default values, with the MAIN OUT output set off. Refer to the System Operations section for how to change the power up settings to either those at power down or to any one of the stored settings. Recall the status screen at any time with the STATUS key; a second press returns the display to the previous screen.

Change the basic generator parameters as described in the Standard Waveform Operation section and switch the output on with the ON key; the lamp above the key will light to show that output is on.

Display Contrast

All parameter settings are displayed on the 20 character x 4 row backlit liquid crystal display (LCD). The contrast may vary a little with changes of ambient temperature or viewing angle but can be optimised for a particular environment by using the front panel contrast control. Insert a small screwdriver or trimmer tool through the adjustment aperture marked LCD and rotate the control for optimum contrast.

Keyboard

Pressing the MENU key calls the top-level menu from which all functions can be accessed. Selections are made from this menu using the display soft-keys and numeric values are then changed using the numeric keys or rotary control, see the Principles of Editing section.

The keys are as follows:

- MENU calls the top-level menu screen from which the main functions can be directly selected. These are WAVEFORM, FREQUENCY, AMPLITUDE, DC OFFSET, SYMMETRY, MODE, UTILITY and AUX OUT. Pressing the associated soft-key of any of these functions calls a further screen which permits the parameters of that function to be edited either from the numeric keypad or by using the rotary control/cursor keys.
- Numeric/Unit keys permit direct entry of a value for the parameter currently selected. Thus, having selected the FREQUENCY screen (by pressing the FREQUENCY soft-key on the MENU screen), a new frequency of 100kHz, for example, is set by pressing 1, 0, 0, kHz. CE (Clear Entry) undoes a numeric entry digit by digit. ESCAPE returns a setting being edited to its last value.
- Eight soft-keys around the display are used to directly set or select parameters from the currently displayed menu; their operation is described in more detail in the next section.
- The STATUS key always returns the display to the default start-up screen which gives an overview of the generator's status. Pressing STATUS again returns the display to the previous screen.

Further explanations will be found in the detailed descriptions of the generator's operation in the sections that follow.

Status Display

After the messages at switch-on, or at any time the STATUS key is pressed, the Status display is shown. With the generator set to the factory defaults (Appendix 2), the display will be:

```
WAVE:sine
FREQ:10.0000kHz  CONT
AMPL:+4.00Vpp
DC:+0.00Vdc  (+0.00V)
```

This display gives an overview of the status of the main generator parameters. If a waveform is selected for which symmetry can be set (see Specification) the additional field of **SYMMetry** is shown to the right of the waveform type, see example below:

```
WAVE:square  SYM:35%
FREQ:10.0000kHz  CONT
AMPL:+4.00V
DC:+0.00Vdc  (+0.00V)
```

For convenience, the WAVEFORM, FREQUENCY, AMPLITUDE, DC OFFSET, SYMMETRY and MODE screens can be directly selected from the Status display, (i.e. without having to first return to the main MENU) by pressing the appropriate soft-key beside WAVE, FREQ, AMPL, etc.

Principles of Editing

Each screen called up by pressing a soft-key on the top level MENU display shows parameter value(s) and/or a list of choices. Choices are made using the soft-key associated with the screen item to be selected. Parameter values can be edited by using the ROTARY CONTROL in combination with the left and right arrowed CURSOR keys, or by direct numeric keyboard entry; The examples which follow assume factory default settings.

A diamond beside a screen item indicates that it is selectable; hollow diamonds identify deselected items and filled diamonds denote selected items. For example, press the **MODE** soft-key on the main menu to get the screen shown below:

MODE	more...◇
◆ continuous	
◇ gated	setup...◇
◇ sweep	setup...◇

The filled diamond indicates that the selected mode is **continuous**. **Gated** or **sweep** modes are selected by pressing the associated soft-key which will make the diamond beside that item filled and the diamond beside **continuous** hollow. This screen also illustrates how an ellipsis (three dots following the screen text) indicates that a further screen follows when that item is selected. In the case of the MODE screen illustrated, pressing the **setup...** soft-key on the bottom line brings up the **SWEEP SETUP** menu; note that selecting this item does not change the **continuous** mode selection.

Some screen items are marked with a double-headed arrow (a split diamond) when selected to indicate that the item's setting can be changed by further presses of the soft-key, by pressing either cursor key or by using the rotary control. For example, pressing the AUX OUT soft-key on the main menu brings up the screen shown below.

AUX OUT
◆ output: on
◇ mode: auto
◇ srce: waveform sync

Repeated presses of the **output** soft-key will toggle the output between **on** and **off**. Similarly when **srce** (source) is selected, repeated presses of the **srce** soft-key will step through all possible selections of the AUX OUT source (**waveform sync**, **trigger**, and **sweep sync**). The rotary control can also be used to step through the selections.

In screens where a parameter with a numeric value is displayed the cursor keys move the edit cursor (a flashing underline) through the numeric field and the rotary control will increment or decrement the value; the step size is determined by the position of the edit cursor within the numeric field. Thus for **FREQUENCY** set to **1.00000 MHz** rotating the control will change the frequency in 1kHz steps. Turning the control quickly will step numeric values in multiple increments.

The display will auto-range up or down as the frequency is changed but the increment size and displayed units are maintained. In the example above (**FREQUENCY** set to **1.00000 MHz**), the lowest frequency that can be set by rotating the control is 1kHz, shown as **0.00100 MHz**. The displayed units can be changed at any time by pressing the appropriate key, e.g. pressing kHz or Hz will change the display for the above example to **1.00000 kHz** or **1000.00 Hz** respectively. To reduce the frequency further using the rotary control it is necessary to move the cursor to set a smaller increment size.

Standard Waveform Operation

When first switched on, and at all subsequent power-ups, unless specified otherwise on the UTILITY menu, the generator will be set to the factory defaults (Appendix 2), with the MAIN OUT off. The basic parameters can be changed as described below.

Setting Generator Parameters

Main Menu

The starting point for changing any parameter is the Main Menu, accessed by pressing the MENU key.

```
◇ WAVEFORM  SYMMETRY ◇  
◇ FREQUENCY      MODE ◇  
◇ AMPLITUDE  UTILITY ◇  
◇ DC OFFSET  AUX OUT ◇
```

The set-up screen for each of the principal parameters is displayed by pressing the appropriate soft-key on this Main Menu; the parameters can then be changed as described below.

Waveform Selection

```
WAVEFORM  
◆sine      +pulse ◇  
◇square    -pulse ◇  
◇triangle  dc only ◇
```

Pressing the **WAVE** soft-key on the main menu gives the **WAVEFORM** screen which lists all the waveforms available. The currently selected waveform (sine with the factory defaults setting) is indicated by the filled diamond; the selection is changed by pressing the soft-key beside the required waveform.

Sine square and triangle are bipolar waveforms centred about the baseline level set from the DC Offset screen; +pulse and -pulse are uni-polar waveforms that are respectively positive and negative with respect to the baseline. When **dc only** is selected the output 'waveform' is the baseline DC voltage only, set from the DC Offset screen.

Frequency

```
FREQUENCY  
  10·0000 kHz  
◆freq      period◇
```

Pressing the **FREQ** key gives the **FREQUENCY** screen. With **freq** selected as shown above, the frequency can be entered directly from the keyboard in any convenient units, e.g. 12.34kHz can be entered directly in kHz but can also be entered as 12340Hz or 0.01234MHz.

With **period** selected instead of **freq** the frequency can be set in terms of a period; the period can be entered directly in any convenient units, e.g. 0.1ms can also be entered as 0.0001s or 100us. The hardware is actually programmed in terms of frequency and when a period entry is made the synthesised frequency is the nearest equivalent value that the frequency resolution and conversion calculation gives. Since the instrument's frequency resolution is 1mHz there will generally be no noticeable loss of precision for frequencies above 1kHz (periods <1ms) but the conversion errors will increase progressively for entries of longer periods; to maintain precision, low frequencies (<1kHz) should be entered in terms of frequency.

Turning the rotary control will increment or decrement the numeric value in steps determined by the position of the edit cursor (flashing underline); the cursor is moved with the left and right arrowed cursor keys.

Note that the upper frequency limits vary for the different waveform types; refer to the Specifications section for details.

Amplitude

```
AMPLITUDE
+4.00 Vpp      Vpp◊
◊srce:50Ω load:hiZ◊
```

Pressing the **AMPLITUDE** soft-key on the main menu gives the **AMPLITUDE** screen.

The actual source impedance of the generator can be set to either 50Ω (factory default) or 600Ω with alternate presses of the **srce** (source) soft-key. In addition, an assumed load of 50Ω, 600Ω or hiZ (open-circuit) can be selected with successive presses of the **load** soft-key. When an amplitude setting is made the selected source impedance and expected load termination are taken into account such that the actual output amplitude is that shown in the display.

The waveform amplitude can be set in terms of peak-to-peak Volts (Vpp), r.m.s. Volts (Vrms) or dBm (referenced to a 50Ω or 600Ω terminating load). The most appropriate units can be selected with successive presses of the units soft-key, which steps through the three options of **Vpp**, **Vrms** and **dBm** in turn. Note that when dBm is selected a **load:hiZ** setting is automatically changed to **load:50Ω** because a termination is always assumed; pressing the **load:50Ω** soft-keys will now only toggle between **load:50Ω** and **load:600Ω** settings.

With the appropriate form of amplitude selected, numeric entries can be made directly from the keyboard in either mV or Volts, e.g. 250mV can be entered as 250mV or 0.25V. Turning the rotary control will increment or decrement the numeric value in steps determined by the position of the edit cursor (flashing underline); the cursor is moved with the left and right arrowed cursor keys.

Alternate presses of the ± key will invert the MAIN OUT output; if DC OFFSET is non-zero, the signal is inverted about the same offset. The exception to this is if the amplitude is specified in dBm; since low level signals are specified in -dBm (0dBm = 1mW into 50Ω = 224mVrms) the - sign is interpreted as part of a new amplitude entry and not as a command to invert the signal.

DC Offset

```
DC OFFSET
program +0.00 Vdc
(actual +0.00 Vdc)
◊srce:50Ω load:hiZ◊
```

Pressing the OFFSET key gives the **DC OFFSET** screen. The offset can be entered directly from the keyboard in mV or Volts, e.g. 100mV can be entered as 100mV or 0.1V. During a new offset entry the ± key can be used at any time to set the offset negative; alternate presses toggle the sign between + and -.

Turning the rotary control will increment or decrement the numeric value in steps determined by the position of the edit cursor (flashing underline); the cursor is moved by the left and right arrowed cursor keys. Because DC offset can have negative values, the rotary control can take the value below zero; although the display may autorange to a higher resolution if a step takes the value close to zero, the increment size is maintained correctly as the offset is stepped negative. For example, if the display shows

program = +205 mVdc

with the cursor in the most significant digit, the rotary control will decrement the offset in 100mV steps as follows:

```
program = +205 mVdc
program = +105 mVdc
program = +005 mVdc
program = -095 mVdc
program = -195 mVdc
```

The actual DC offset at the MAIN OUT socket is attenuated by the fixed-step output attenuator when this is in use. Since it is not obvious when the signal is being attenuated the actual offset is shown in brackets as a non-editable field below the programmed value.

For example, if the amplitude is set to 2.5Vpp the output is not attenuated by the fixed attenuator and the actual DC offset (in brackets) is the same as that set. The **DC OFFSET** display shows:

```
DC OFFSET
program +1.50 Vdc
(actual +1.50 Vdc)
◊srce:50Ω load:hiZ◊
```

If the amplitude is now reduced to 250mVpp which introduces the attenuator, the actual DC offset changes by the appropriate factor:

```
DC OFFSET
program +1.50 Vdc
(actual +151 mVdc)
◊srce:50Ω load:hiZ◊
```

The above display shows that the set DC offset is +1.50V but the actual offset is +151mV. Note that the actual offset value also takes into account the true attenuation provided by the fixed attenuator, using the values determined during the calibration procedure. In the example displayed the output signal is 250mVpp exactly and takes account of the small error in the fixed attenuator; the offset is 151.mV exactly, taking account of the effect of the known attenuation (slightly less than the nominal) on the set offset of 1.50V.

Whenever the set DC offset is modified by a change in output level in this way a warning message that this has happened will be displayed. Similarly, because waveform clipping occurs if the DC offset plus signal peak exceeds $\pm 10V$, a warning message will be displayed if this condition is set. This is explained more fully in the Warnings and Error Messages section.

When **dc only** is selected on the **WAVEFORM** screen the output 'waveform' is the baseline DC voltage only, set from this screen. Since there is no switching waveform, the DC level can be set over the full $\pm 10V$ range; the attenuator is automatically used to give a setting resolution down to 1mV below 1Vdc and the **actual** value will always match the **program** value.

The source impedance and assumed load can also be set from this screen.

Symmetry

```
SYMMETRY          50%◆
◊20%              60%◊
◊30%      50 %   70%◊
◊40%              80%◊
```

Pressing **SYMMETRY** on the Main menu gives the SYMMETRY screen.

Symmetry can only be varied for squarewave and pulse waveforms; selecting **SYMMETRY** for any other waveform will cause the error message **Symmetry has no effect on this wave** to be displayed before the **SYMMETRY** screen is shown.

For squarewave and pulse waveforms the symmetry can be set between 20% and 80% (mark:space). 20%, 30%, etc. can be set directly with the appropriate soft-key or any in-range value can be set with a 1% resolution by direct numeric entry or by using the rotary control.

AUX Output

AUX OUT is a multifunction CMOS/TTL level output that can be automatically or manually set to be any of the following:

- **waveform sync** : A sync signal phase coincident with the MAIN OUT waveform. For sine and triangle waves the sync waveform rising edge is at the 0° phase point of MAIN OUT and the falling edge is at the 180° phase point. For square waves and pulses both phase and symmetry are coincident with MAIN OUT.
- **trigger** : Outputs a replica of the current trigger signal, i.e. the trigger source selected on the TRIG/GATE SETUP screen.
- **sweep sync** : Outputs the sweep trigger and marker signals.

The setting up of the signals themselves is discussed in the relevant sections later in this manual. Pressing the AUX OUT key calls the **AUX OUT** setup screen.

```
AUX OUT
◆output: on
◇ mode: auto
◇ srce: waveform sync
```

AUX OUT is turned on and off by alternate presses of the **output** soft-key.

The selection of the signal to be output from the AUX OUT socket is made using the **srce** (source) soft-key; repeated presses of **srce** cycle the selection through the choices (**waveform sync**, etc.) listed above. Alternatively, with the **srce** selected (double-headed arrow) the rotary control or cursor keys can be used to step backwards and forwards through the choices.

The source selection of the AUX OUT waveform can be made automatic (**auto**) or user-defined (**manual**) with alternate presses of the **mode** soft-key. In automatic mode the AUX OUT waveform most appropriate for the current main waveform is selected.

For example, **waveform sync** is automatically selected for continuous waveforms but **trigger** is selected in gated waveform mode.

The automatic selection can still be changed manually by the **srce** soft-key even when **auto** mode has been selected but the selection will revert to the automatic choice if the mode is changed. **Manual** must be selected by the **mode** soft-key for a source other than the automatic choice to remain set. The **auto** selection will generally set the most frequently used signal, e.g. **waveform sync** for all continuous main waveforms.

Warnings and Error Messages

Two classes of message are displayed on the screen when an illegal combination of parameters is attempted.

WARNING messages are shown when the entered setting causes some change which the user might not necessarily expect. Examples are:

1. Changing the amplitude from, for example, 2.5 Volts pk-pk to 25mV pk-pk brings in the step attenuator; if a non-zero offset has been set then this will now be attenuated too. The message **DC OFFSET CHANGED BY AMPLITUDE** will be shown temporarily on the screen but the setting will be accepted; in this case the actual, attenuated, offset will be shown in brackets below the set value.
2. With the output level set to 10V pk-pk, increasing the DC offset beyond $\pm 5V$ will cause the message **DC OFFSET + LEVEL MAY CAUSE CLIPPING**. The offset change will be accepted (producing a clipped waveform) and the user may then choose to change the output level or the offset to produce a signal which is not clipped. (**clip?**) will show in the display beside **AMPLITUDE** or **DC OFFSET** while the clipped condition exists.

ERROR messages are shown when an illegal setting is attempted, most generally a number outside the range of values permitted. In this case the entry is rejected and the parameter setting is left unchanged. Examples are:

1. Entering a frequency of 2MHz for a triangle waveform. The error message:
Frequency too high for the triangle wave is shown.
2. Entering an amplitude of 25Vpp. The error message:
Number too high - value unchanged is shown.

The messages are shown on the display for approximately two seconds. The last two messages can be viewed again by pressing the **last error...** soft-key on the UTILITY screen, see System Operations section.

Each message has a number and the full list appears in Appendix 1.

The default set-up is for all warning and error messages to be displayed and for a beep to sound with each message. This set-up can be changed on the **error...** menu on the UTILITY screen. The **error** menu is shown below:

◇error beep:	ON
◇error message:	ON
◇warn beep:	ON
◇warn message:	ON

Each feature can be turned ON and OFF with alternate presses of the associated soft-key; the factory default is for all features to be ON. If the setting is changed and is required for future use it should be saved by changing the **POWER-ON SETTING** on the **power on...** menu of the UTILITY screen to **restore last setup**.

Sweep Operation

General

Principles of Sweep Operation

All waveforms can be swept phase-continuously from 0.2Hz up to the maximum frequency for the selected waveform. Although the frequency is stepped, not truly swept as in an analogue generator, the short step interval (100us) gives a close approximation to an analogue instrument except for the widest sweeps in the shortest time; see the Frequency Stepping Resolution section for further discussion.

The frequency steps are calculated in real-time using a 2-stage process. Major steps are calculated every 5ms with full precision; the values calculated follow a linear or log sweep law depending on the choice made on the **SWEEP SPACING** menu. Within each major step minor steps are calculated every 100us by linear interpolation for both linear and log sweeps. Linear interpolation gives a small loss of precision for the minor points of log sweeps but the error is still less than ± 1 digit of the displayed frequency except for the widest sweeps in the shortest time. The advantage that linear interpolation of the minor points gives is that it is fast enough for all points (major and minor) to be calculated in real time. This in turn permits Start, Stop and Marker frequencies to be changed with Sweep still running, making performance much closer to that of an analogue instrument.

Sweep mode is turned on and off either by the **sweep** soft-key on the **MODE** screen (accessed from the Main menu), by the **on** and **off** soft-key on the **SWEEP SETUP** screen, accessed by pressing **setup...** on the **MODE** screen, or by the **on** and **off** soft-keys on any of the **SWEEP SETUP** sub-menus. Turning sweep off from any of the latter menus always returns the operating mode to continuous.

Connections for Sweep Operation. Aux Out and Trig In

Sweeps are generally used with an oscilloscope or hard-copy device to investigate the frequency response of a circuit. The MAIN OUT is connected to the circuit input and the circuit output is connected to an oscilloscope or, for slow sweeps, a recorder.

An oscilloscope can be triggered by connecting its trigger input to the generator's AUX OUT; AUX OUT defaults to **sweep sync** when sweep is turned on. **sweep sync** goes low at the start of sweep and high at the last frequency step of the sweep; depending on the sweep time set this should be long enough for an oscilloscope to retrace, for example.

AUX OUT will additionally output a marker pulse if the marker frequency is set within the sweep frequency range. See Sweep Marker section for setting marker frequency.

For triggered sweeps, a trigger signal must be provided at the front panel TRIG/GATE IN socket or by pressing the MAN TRIG key or by a remote command.

The generator does not provide a ramp output for use with X-Y displays or recorders.

Setting Sweep Parameters

Pressing the **sweep setup...** soft-key on the **MODE** screen displays the **SWEEP SETUP** screen.

SWEEP SETUP	off	◇
◇ range...	type...	◇
◇ time...	spacing...	◇
◇ manual...	marker...	◇

Menus for setting up the range, time (sweep rate), type (continuous, triggered, etc.) spacing (lin/log) and marker position are all accessed from this screen using the appropriate soft-key. In addition the control screen for manual sweep (i.e. sweeping using the rotary control) is selected from this screen and Sweep Mode itself is turned on and off with alternate presses of the **on** and **off** soft-key; sweep can also be turned on by the **sweep** soft-key on the **MODE** screen.

On all the following menus, pressing the **done** soft-key returns the display to this **SWEEP SETUP** screen. On all the following menus sweep can be turned on and off with alternate presses of the **on** and **off** soft-key. Turning sweep off from this or the following menus always returns the mode to continuous.

Sweep Range

Pressing the **range...** soft-key calls the **SWEEP RANGE** screen.

```
SWEEP RANGE      off ◊
◊start: 100.00 kHz
◊stop:  20.000 MHz
◊centre/span    done ◊
```

The maximum sweep range for all waveforms is 0.2Hz to 20MHz[10MHz], except triangle (1MHz). Sweep range can be defined by start and stop frequencies or in terms of a centre frequency and span. **start** and **stop** soft-keys permit the two end points of the sweep to be set directly from the keyboard or by using the rotary control; frequencies can be entered with a resolution of 0.1Hz (or 5 digits) but in sweep mode the instrument operates with an increment resolution of 0.2Hz and the actual frequency of any particular step will be rounded up to the nearest 0.2Hz increment. The start frequency must be lower than the stop frequency (but see Sweep Type for selecting sweep direction).

Pressing the **centre/span** soft-key changes the screen to permit entry in terms of **centre** frequency and sweep **span** about that frequency; pressing the **start/stop** soft-key on that screen returns the display to the start and stop frequency form of entry.

Note that when the sweep is displayed in terms of centre frequency and span, the span will be shown to the nearest 0.2Hz increment but the centre frequency can be shown to 0.1Hz resolution.

Sweep Time

Pressing the **time...** soft-key calls the **SWEEP TIME** screen.

```
SWEEP TIME      off ◊
                0.05 s
                                done ◊
```

The sweep time can be set from 0.05s to 999s with 3-digit resolution by direct keyboard entry or by using the rotary control. The shortest sweep times will have the fewest steps (a 100ms sweep will have only 1000 steps whereas a 10s sweep will have 100,000 steps) and will consequently have a coarse stepping resolution with very wide sweeps, see Frequency Stepping Resolution section for more discussion.

Sweep Type

Pressing the **type** soft-key calls the **SWEEP TYPE** screen.

```
SWEEP TYPE      off ◊
◄mode:continuous
◊direction: up
◊sync: on       done ◊
```

This screen is used to set the sweep mode (continuous; triggered; hold and reset; manual) and sweep direction.

Successive presses of the **direction** soft-key select one of the following sweep directions:

- up** start frequency to stop frequency.
- down** stop frequency to start frequency.
- up/down** start frequency to stop frequency and back to start frequency.
- down/up** stop frequency to start frequency and back to stop frequency.

The total sweep time is always that set on the **SWEEP TIME** screen, i.e. for **up/down** and **down/up** operation the sweep time in each direction is half the total. Similarly the total number of steps is the same for all choices, i.e. there will be half the number of steps in each direction for **up/down** and **down/up** operation. In the sweep mode descriptions which follow the direction is assumed to be **up** but all modes can be used with all sweep directions.

In **continuous** mode the generator sweeps continuously between the start and stop frequencies, triggered repetitively by an internal trigger generator whose frequency is determined by the sweep time setting. At the stop frequency the generator resets to the start frequency after a delay long enough for an oscilloscope to retrace, for example, and begins a new sweep.

If **sync** is set to **on** (the default) the generator actually steps from the stop frequency to zero frequency and then starts the next sweep from the first point of the waveform, synchronised to the (internally generated) trigger signal. This is useful because the sweep always starts from the same point in the waveform but the waveform discontinuity can be undesirable in some circumstances, e.g. filter evaluation.

With **sync** set to **off**, the frequency steps directly and phase continuously from the stop frequency to the start frequency but is not synchronised to the software-generated trigger signal.

In **triggered** mode the generator holds the output at the start frequency until it recognises a trigger. When triggered, the frequency sweeps to the stop frequency, resets, and awaits the next trigger. If **sync** is set to **on** the frequency resets to zero frequency (i.e. no waveform) and starts a new sweep at the first point of the waveform when the next trigger is recognised. If **sync** is set to **off** the waveform resets to the start frequency and runs at that frequency until the next trigger initiates a new sweep.

In **hold & reset** mode the generator holds the output at the start frequency until it recognises a trigger; when triggered, the frequency sweeps to the stop frequency and holds. At the next trigger the output is reset to the start frequency where it is held until the next sweep is initiated by a further trigger. If **sync** is set to **off** the output operates exactly as described above; if **sync** is set to **on** the frequency actually goes to zero at the start and begins each new sweep at the first point of the waveform.

For **triggered** and **hold & reset** modes the trigger source can be the internal trigger generator, an external signal applied to TRIG IN, pressing the MAN TRIG key on the front panel, or a remote command. The trigger source is selected on the TRIG/GATE SETUP screen, called by pressing the **gated setup...** soft-key on the **MODE** screen; refer to the Gate Source paragraph in the Gated Mode section for further details.

In **manual** mode the whole sweep process is controlled from the **MANUAL SWEEP** screen.

Manual Sweep

Before manual control can be used, **manual** must first be selected on the **SWEEP TYPE** screen, see above. Pressing the **manual** soft-key on the **SWEEP SETUP** screen then calls the **MANUAL SWEEP** screen; if **manual** has not first been set as the sweep type, the message **manual sweep mode not selected** will be displayed before the **MANUAL SWEEP** screen is shown. Sweep parameters unique to manual operation are set on the **MANUAL SWEEP** screen and Manual Sweep operation using the rotary control is only possible whilst this screen is shown.

```

MANUAL SWEEP    off ◊
 12.30%  2.5477 MHz
◊wrap:on
◊res: medium    done ◊

```

In manual mode the frequency can be stepped through the sweep range, defined on the **SWEEP RANGE** screen, using the rotary control. Clockwise rotation sweeps the frequency up and anticlockwise sweeps the frequency down; the **direction** setting on the **SWEEP TYPE** screen is ignored in Manual Sweep mode. As the frequency is swept the display shows both the frequency at each step and the step position within the sweep, expressed as a percentage of the total sweep range; 0% is the Start frequency and 100% is the Stop frequency. The resolution of the frequency steps is set by the **resolution** soft-key. With **res: coarse** the sweep range is divided into 100 (1%) increments for the purposes of manual stepping; **medium** splits it into 1000 (0.1%) steps and **fine** splits it into 10,000 (0.01%) steps. Each complete turn of the rotary knob corresponds to 36 steps; turning the rotary control rapidly will cause the frequency to jump by more than one step. Sweep spacing (linear or logarithmic) is as set on the **SWEEP SPACING** menu (see Sweep Spacing section below).

The frequency stepping resolution can be changed during a manual sweep such that **coarse** resolution can be used to quickly find a frequency of interest and **fine** resolution then selected to step the frequency in smaller increments.

If **wrap** is set **on** the sweep wraps-round from **start** frequency to **stop** frequency and vice-versa; if **wrap** is set **off** the sweep finishes at either the **start** or **stop** frequency depending on the direction of the rotary control.

Exiting Manual Sweep mode (by pressing the **done** soft-key) returns the display to the **SWEEP SETUP** screen with the instrument running at the last selected step frequency; the instrument is still in Sweep mode but not sweeping.

Sweep Spacing

Pressing the **spacing...** soft-key on the **SWEEP SETUP** screen calls the **SWEEP SPACING** screen.

```

SWEEP SPACING  off ◊
◆logarithmic
◊linear
                                     done ◊

```

With **linear** selected the sweep changes the frequency at a linear rate; with **logarithmic** selected the sweep spends an equal time in each frequency decade.

Sweep Marker

Pressing the **marker...** soft-key on the **SWEEP SETUP** screen calls the **MARKER FREQ** screen.

```

MARKER FREQ    off ◊
program:10.000 MHz
                                     done ◊

```

When set to **sweep sync** AUX OUT will additionally output a marker pulse if the marker frequency is set within the sweep frequency range. The marker pulse is approximately 25% of the amplitude of the sweep sync pulse.

A new marker frequency can be programmed directly from the keyboard or by using the rotary control and cursor keys. The marker can be programmed to be any frequency within the sweep range but the actual frequency will be that of the nearest 'minor' step, see Principles of Operation section for an explanation of major and minor frequency steps.

The minimum marker duration is 100us (1 minor step) but for longer sweeps the marker duration is increased (in 100us increments) such that is never less than 1/250th of the complete sweep in order to keep the marker visible if the whole sweep is displayed on an oscilloscope. Thus for a sweep time of 100ms the marker duration would be 400us. The first 100us increment represents the closest frequency step to the programmed marker value.

The marker will not show if it is programmed to a frequency outside of the sweep range.

Frequency Stepping Resolution

The generator frequency is stepped, not truly linearly swept, between the Start and Stop frequencies. The number of discrete frequency steps in a sweep is determined by the sweep time set on the **SWEEP TIME** screen; the size of each step, i.e. the frequency stepping resolution, is determined by the number of steps and the sweep range (set on the **SWEEP RANGE** screen).

At the shortest sweep times (i.e. the fewest steps) with the widest frequency spans the frequency changes will be quite large at each step; if the output is applied to a filter, for example, the response will be a succession of step-change levels with (at higher frequencies) many cycles of the same frequency at each step. This is a limitation of a DDS generator in sweep mode but in part, of course, this effect can only be created because of the very wide sweeps that can be achieved with DDS techniques; analogue generators usually have more restricted capabilities.

General

In Gated mode the generator outputs the waveform whenever the gating signal is high. The generator is not synchronised with the gate source and the start and stop phase of the generator waveform is therefore unpredictable. Except for the ability to turn the output signal on and off, Gated mode is identical to Continuous mode. The same frequency setting is used in the two modes. This permits the signal to be set up and applied before enabling the Gate.

Gated mode is turned on by pressing the **gated** soft-key on the **MODE** screen, called by the **MODE** soft-key on the main menu.

```
MODE                more...◇
◇continuous
◆gated              setup...◇
◇sweep              setup...◇
```

The selection of the gate source signal is made by pressing the **setup...** soft-key opposite **gated** on the **MODE** screen:

```
TRIG/GATE SETUP
◆source: manual
◇int period: 90.8ms
```

Gate Source

Successive presses of the **source:** soft-key on the **TRIG/GATE SETUP** screen step the source through the three possible options of **manual**, **external** and **internal**.

With **manual** selected the generator output is turned on and off by successive presses of the front panel MAN TRIG key or by the *TRG command from a remote interface.

With **external** selected the generator output runs when the signal at the TRIG/GATE IN socket is high; this input has a TTL level (1.5V) threshold. The minimum pulse width that can be used in this mode is 100ns and the maximum repetition rate is 100kHz. The maximum signal level that can be applied without damage is $\pm 10V$.

With **internal** selected the generator is gated by an internal gate source whose period is set by selecting **int period** on the same **TRIG/GATE SETUP** screen.

```
TRIG/GATE SETUP
◇source:internal
◆int period: 12.2ms
```

The period can be set from 0.2ms to 999s by direct keyboard entries in ms or seconds. Turning the rotary control will increment or decrement the numeric value in steps determined by the position of the edit cursor (flashing underline); the cursor is moved with the left and right arrowed cursor keys. The internal source is a square wave; the duration of the gate is therefore 0.1ms to 499.5s in step with the source period of 0.2ms to 999s.

AUX OUT in Gate Mode

When Gated mode is selected the AUX OUT source automatically defaults to **trigger**; **trigger** is a replica of the actual gate signal, i.e. the signal at the TRIG/GATE IN socket, the internal gate source or the high/low condition 'toggled' by alternate presses of the MAN TRIG key or the *TRG remote command.

Tone Mode

General

In Tone mode the output is stepped through a user-defined list of up to 16 frequencies under the control of the selected trigger source. The frequency list is defined using the **TONE SETUP** screen and the trigger source is selected on the TRIG/GATE SETUP screen. Tone mode is turned on using the **tone** soft-key on the **MODE** screen.

Tone Frequency

Press the **tone setup...** soft-key on the **MODE** screen, called by pressing the **MODE** soft-key on the main menu to get the **TONE SETUP** screen:

```
TONE SETUP
source as gate setup
◇1.00000 kHz #1
◆2.00000 kHz del◇
```

Each frequency in the list can be changed by pressing the appropriate soft-key and entering the new value from the keyboard. The selected frequency can be deleted from the list by pressing the **del** (delete) soft-key. Additional frequencies can be added to the end of the list by selecting **end of list** with the appropriate soft-key and entering the new frequency from the keyboard.

The whole list can be scrolled back and forward through the display using the rotary control.

Tone Gate Source

The tone frequency steps (changes) when the specified trigger signal goes high and continues until the level changes again, at which point the output immediately returns to the DC Offset level specified; the output is then gated off until the next occurrence of the trigger signal at which time the next frequency in the list is gated on. Note that, just as with Gated mode, the tone frequency is not synchronised with the tone stepping gate source and the start and stop phase of each tone is therefore entirely unpredictable.

The trigger signal used for stepping the tone is exactly the same source as that used for Gated mode and is set up on the **TRIG/GATE SETUP** screen, called by pressing the **gated setup...** soft-key on the **MODE** screen. The tone switching trigger source can be **manual** (front panel MAN TRIG key, or remote command), an **external** signal applied to the TRIG/GATE IN socket, or **internal** from the internal trigger generator. Refer to the Gate Source paragraph in the Gated Mode section for selection of the trigger source.

When **external** is the selected tone stepping trigger source the maximum switching frequency that is recommended (applied to the TRIG/GATE IN socket) is 1kHz.

General

FSK (Frequency Shift Keying) mode permits fast phase-continuous switching between two frequencies within the range of 1Hz to 20MHz [10MHz]. All other parameters of the waveform (amplitude, offset, symmetry) remain the same as the frequency is switched.

FSK mode is turned on by pressing the **FSK** soft-key on the **MODE** screen, called by pressing the **MODE** soft-key on the main menu.

Frequency Setting

The two frequencies **f0** and **f1**, between which the waveform is switched, are set on the FSK FREQUENCIES screen, called by pressing the **FSK set-up...** soft-key on the **MODE** screen.

<pre>FSK FREQUENCIES source as gate setup ◆f0: 1.000 kHz ◇f1: 10.0000 kHz</pre>

With each frequency selected in turn (filled diamond) the frequency can be set using direct numeric keyboard entries or by using the cursor keys and rotary control.

Trigger Source

The trigger source is the same source as that used for Gated and Tone modes and is accessed and set up in the same way from the **TRIG/GATE SETUP** screen, called by pressing the **gated setup...** soft-key on the **MODE** screen.

For an external trigger, **f0** is the frequency output with the TRIG/GATE IN signal low and **f1** is the frequency output with the TRIG/GATE IN signal high.

Modulation

Amplitude Modulation of the carrier is possible by applying a suitable signal (which can be AC coupled if required) to the front panel VCA IN socket. A positive voltage increases the output amplitude and a negative voltage decreases the amplitude. The modulating signal is applied at the appropriate level to obtain the modulation depth required at the set output amplitude. If the output amplitude is changed the amplitude of the modulating signal will have to be changed if the same modulation depth is to be maintained. Note that clipping will occur if the combination of amplitude setting and VCA IN signal attempts to drive the output above 20Vpp open-circuit voltage (10Vpp into 50Ω).

The VCA IN signal is applied to the amplifier chain prior to the output attenuators. The amplifier itself is controlled over a limited range (~10dB) and the full amplitude range is achieved by switching in up to five -10dB attenuation stages. Peak modulation cannot exceed the maximum of the 'range' within which the output has been set by choice of amplitude setting. It is up to the user to observe the waveforms when using external VCA and to make adjustments if the waveform is clipping.

Within each 'range' the maximum output setting at which clipping is avoided is reduced from range maximum to half this value as modulation is increased from 0% to 100%; 100% modulation will be achieved at this mid-range setting with a VCA IN signal of approximately 2.5Vpp.

Any waveform can be modulated, including DC. Modulation frequency range is DC to 100kHz.

Modulating the generator with a squarewave gives step changes in the output amplitude which are suitable for testing signal compressors and automatic gain control circuits.

Suppressed Carrier Modulation can be achieved by first DC biasing the VCA IN sufficient to suppress the carrier and then applying the modulating signal.

System Operations from the Utility Menu

Pressing the **UTILITY** soft-key on the main menu calls a list of further menus which give access to various system operations including storing/recalling set-ups from non-volatile memory, error messages, power-on settings and calibration.

Storing and Recalling Set-ups

Complete waveform set-ups can be stored to or recalled from non-volatile RAM using the menus called by the **store...** and **recall...** soft-keys on the **UTILITIES** screen.

Pressing **store...** calls the store screen:

```
Save to store No: 1
◇ execute
```

Nine stores, numbered 1 to 9 inclusive, are available. Select the store using the rotary control or direct keyboard entry and press **execute** to implement the store function.

Pressing **recall...** calls the recall screen:

```
Recall store No: 1
◇ set defaults
◇ execute
```

In addition to the user-defined stores, the factory defaults can be reloaded by pressing the **set defaults** soft-key. Note that loading the defaults does not change the set-ups stored in memories 1 to 9, or the RS-232/USB interface settings.

Warnings and Error messages

The default setup is for all warning and error messages to be displayed and for a beep to sound with each message. This setup can be changed on the **error...** menu:

```
◇ error beep: ON
◇ error message: ON
◇ warn beep: ON
◇ warn message: ON
```

Each feature can be turned ON or OFF with alternate presses of the appropriate soft-key.

The last two error messages can be viewed by pressing the **last error...** soft-key on the **UTILITIES** screen. Each message has a number and the full list appears in Appendix 1. See also Warnings and Error Messages in the Standard Waveform Operation section.

Remote Interface Setup

Pressing **remote...** calls the **REMOTE SETUP** screen which permits RS-232/USB choice and selection of address and Baud rate. Full details are given in the Remote Operation section.

Power On Setting

Pressing the **power on...** soft-key calls the **POWER ON SETTING** screen:

```
POWER ON SETTING
◇ default values
◇ restore last setup
◆ recall store no. 1
```

The setting loaded can be selected with the appropriate soft-key to be **default values** (the default setting), **restore last setup** (i.e. the settings at power down are restored at power up) or any of the settings stored in non-volatile memories 1 to 9. **Default values** restores the factory default settings, see Appendix 2.

Calibration

Pressing **calibrate...** calls the calibration routine, see Calibration section.

Calibration

All parameters can be calibrated without opening the case, i.e. the generator offers 'closed-box' calibration. All adjustments are made digitally with calibration constants stored in Flash. The calibration routine requires only a DVM, an oscilloscope and a frequency counter and takes no more than a few minutes.

The crystal in the timebase is pre-aged but a further ageing of up to ± 5 ppm can occur in the first year. Since the ageing rate decreases exponentially with time it is an advantage to recalibrate after the first 6 month's use. Apart from this it is unlikely that any other parameters will need adjustment.

Calibration should be carried out only after the generator has been operating for at least 30 minutes in normal ambient conditions.

Equipment Required

- 3½ digit DVM with 0.25% DC accuracy and 0.5% AC accuracy at 1kHz.
- Frequency counter capable of measuring 20.00000MHz.
- An oscilloscope for the Symmetry adjustment (CAL 13 & CAL14).

The DVM is connected to the MAIN OUT and the counter to the AUX OUT.

Frequency meter accuracy will determine the accuracy of the generator's clock setting and should ideally be ± 1 ppm.

Calibration Procedure

The calibration procedure is accessed by pressing the **calibrate...** soft-key on the **UTILITIES** screen.

```
CALIBRATION SELECTED
  Are you sure ?
◇ password...  tests...◇
◇ exit        continue ◇
```

The software provides for a 4-digit password in the range 0000 to 9999 to be used to access the calibration procedure. If the password is left at the factory default of 0000 no messages are shown and calibration can proceed as described in the Calibration Routine section; only if a non-zero password has been set will the user be prompted to enter the password.

Setting the Password

On opening the Calibration screen press the **password...** soft-key to show the password screen:

```
ENTER NEW PASSWORD
  ----
```

Enter a 4-digit password from the keyboard; the display will show **CONFIRM NEW PASSWORD**. Re-enter the password; the display will show the message **NEW PASSWORD STORED!** for two seconds and then revert to the **UTILITIES** menu. If any keys other than 0-9 are pressed while entering the password, or if the password is re-entered incorrectly, the message **ILLEGAL PASSWORD!** will be shown.

Using the Password to Access Calibration or Change the Password

With the password set, pressing **calibration...** on the **UTILITIES** screen will now show:

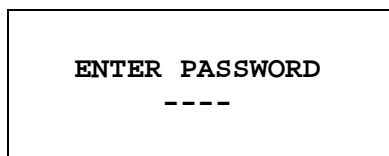

When the correct password has been entered from the keyboard the display changes to the opening screen of the calibration routine and calibration can proceed as described in the Calibration Routine section. If an incorrect password is entered the message **INCORRECT PASSWORD!** is shown for two seconds before the display reverts to the **UTILITIES** menu.

With the opening screen of the calibration routine displayed after correctly entering the password, the password can be changed by pressing **password...** soft-key and following the procedure described in Setting the Password. If the password is set to 0000 again, password protection is removed.

The password is held in Flash. In the event of the password being forgotten, contact the manufacturer for help in resetting the instrument.

Calibration Routine

The calibration procedure proper is entered by pressing **continue** on the opening Calibration screen; pressing **exit** returns the display to the **UTILITIES** menu. At each step the display changes to prompt the user to adjust the rotary control or cursor keys, until the reading on the specified instrument is at the value given. The cursor keys provide coarse adjustment, and the rotary control fine adjustment. Pressing **next** increments the procedure to the next step; pressing **previous** decrements back to the previous step. Alternatively, pressing **exit** returns the display to the last CAL screen at which the user can choose to either **save new values, recall old values** or **calibrate again**.

The first two displays specify the connections and adjustment method. The subsequent displays, CAL 01 to CAL 15, permit all adjustable parameters to be calibrated.

The full procedure is listed below; the name of the control signal being adjusted at each step and the default DAC value are shown in brackets. The display itself shows a summary of the step adjustment procedure and the actual DAC value.

- CAL 01 Output DC offset zero; adjust for $0V \pm 5mV$ (DCOFFSET, 0007).
- CAL 02 Output DC offset +ve full scale; adjust for $10V \pm 20mV$ (DCOFFSET, -1973).
- CAL 03 Output DC offset -ve full scale; check for $-10V \pm 20mV$ (DCOFFSET, 1959).
- CAL 04 Multiplier control zero offset; adjust for minimum output (AMPL, 0008).
- CAL 05 Multiplier offset; adjust for $0V \pm 5mV$ (MULTOFST -1494).
- CAL 06 Squarewave, note offset.
- CAL 07 Waveform offset; adjust for CAL06 value $\pm 10mV$ (WAVOFST, -0293).
- CAL 08 Waveform full-scale; adjust for $10V \pm 10mV$ (AMPL, 1814).
- CAL 09 Squarewave full scale; adjust for $10V \pm 10mV$ (SQLEVEL, 0701).
- CAL 10 -20dB output attenuator; adjust for $1V \pm 1mV$ (AMPL, 1813).
- CAL 11 -40dB output attenuator; adjust for $0.1V \pm 0.1mV$ (AMPL, 1818).
- CAL 12 -10dB intermediate attenuator; adjust for $3.16V \pm 10mV$ (AMPL 1798).
- CAL 13 Squarewave symmetry (50%); adjust for $50\mu s \pm 0.1\mu s$ (SYM, 0000). 10kHz
- CAL 14 Squarewave symmetry (75%); adjust for $75\mu s \pm 0.1\mu s$ (SYM, -0513). 10kHz
- CAL 15 Clock calibrate. 10MHz at main and aux outputs; adjust to $\pm 1ppm$. Fail if outside these limits, ± 1700 shown on the display (CLKCAL).

Each adjustment step allows the processor to calculate a calibration constant which is stored in Flash. Because each step allows a very wide adjustment range it is possible to stop the instrument functioning completely; if this is suspected the default values listed above should be set and a complete recalibration should then be performed.

Remote Calibration

Calibration of the instrument may be performed over the RS-232 or USB interface. To completely automate the process the multimeter and frequency meter will also need to be remote controlled and the controller will need to run a calibration program unique to this instrument.

The remote calibration commands allow a simplified version of manual calibration to be performed by issuing commands from the controller. The controller must send the CALADJ command repeatedly and read the DMM or frequency meter until the required result for the selected calibration step is achieved. The CALSTEP command is then issued to accept the new value and move to the next step.

While in remote calibration mode very little error checking is performed and it is the controller's responsibility to ensure that everything progresses in an orderly way. Only the following commands should be used during calibration.

WARNING: Using any other commands while in calibration mode may give unpredictable results and could cause the instrument to lock up, requiring the power to be cycled to regain control.

CALIBRATION <cpd> [,nrf] The calibration control command. <cpd> can be one of three sub-commands:-

START Enter calibration mode; this command must be issued before any other calibration commands will be recognised.

SAVE Finish calibration, save the new values and exit calibration mode.

ABORT Finish calibration, do not save the new values and exit calibration mode.

<nrf> represents the calibration password. The password is only required with CALIBRATION START and then only if a non-zero password has been set from the instrument's keyboard. The password will be ignored, and will give no errors, at all other times. It is not possible to set or change the password using remote commands.

CALADJ <nrf> Adjust the selected calibration value by <nrf>. The value must be in the range -100 to +100. Once an adjustment has been completed and the new value is as required the CALSTEP command must be issued for the new value to be accepted.

CALSTEP Step to the next calibration point.

For general information on remote operation and remote command formats, refer to the following sections.

Remote Operation (TG2000 only)

The instrument can be remotely controlled via its RS-232 or USB interfaces. When using RS232 it can either be the only instrument connected to the controller or it can be part of an addressable RS-232 system which permits up to 32 instruments to be addressed from one RS-232 port.

The USB interface operates internally through the instrument's RS232 interface. USB remote control consequently operates exactly as described for single-instrument RS232 use but via the USB connector.

Application software on the computer can then access the instrument as if it is connected via the RS232 connector. The USB port cannot, however, be used as part of an addressable RS232 system.

Remote command format and the remote commands themselves are detailed in the Remote Commands chapter.

Address and Baud Rate Selection

For successful operation, each instrument connected to the addressable RS-232 system must be assigned a unique address and all must be set to the same Baud rate.

The instrument's remote address for operation on the RS-232 interface is set via the **REMOTE** menu, called using the **remote...** soft-key on the **UTILITIES** screen, see System Operations section.

```
REMOTE
┆interface: RS-232
┆address: 05
┆baud rate: 9600
```

With **address** selected, the soft-key, cursor keys or rotary control can be used to set the address.

With **baud rate** selected, the soft-key, cursor keys or rotary control can be used to set the baud rate for the RS-232 interface.

Remote/Local Operation

At power-on the instrument will be in the local state with the REMOTE lamp off. In this state all keyboard operations are possible. When the instrument is addressed to listen and a command is received the remote state will be entered and the REMOTE lamp will be turned on. In this state the keyboard is locked out and remote commands only will be processed. The screen reverts to the STATUS display but with the actual DC Offset replaced in the bottom right-hand corner by a **local** soft-key.

The instrument may be returned to the local state by pressing the **local** key; however, the effect of this action will remain only until the instrument is addressed again or receives another character from the interface, when the remote state will once again be entered.

RS-232 Interface

RS-232 Interface Connector

The 9-way D-type serial interface connector is located on the instrument rear panel. The pin connections are as shown below:

Pin	Name	Description
1	–	No internal connection
2	TXD	Transmitted data from instrument
3	RXD	Received data to instrument
4	–	No internal connection
5	GND	Signal ground
6	–	No internal connection
7	RXD2	Secondary received data (addressable RS-232 only)
8	TXD2	Secondary transmitted data (addressable RS-232 only)
9	GND	Signal ground (addressable RS-232 only)

Single Instrument RS-232 Connections

For single instrument remote control only pins 2, 3 and 5 are connected to the PC. However, for correct operation links must be made in the connector at the PC end between pins 1, 4 and 6 and between pins 7 and 8, see diagram. Pins 7 and 8 of the instrument must **not** be connected to the PC, i.e. do not use a fully wired 9-way cable.

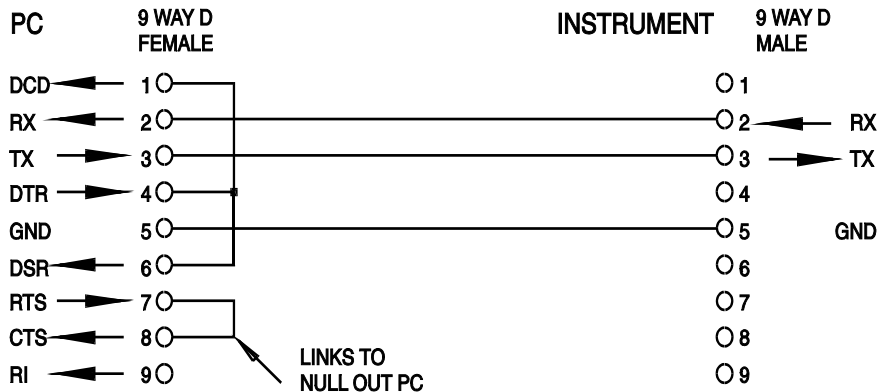

Baud Rate is set as described above in Address and Baud Rate Selection; the other parameters are fixed as follows:

Start Bits: 1 Parity: None
 Data Bits: 8 Stop Bits: 1

Addressable RS-232 Connections

For addressable RS-232 operation pins 7, 8 and 9 of the instrument connector are also used. Using a simple cable assembly, a 'daisy chain' connection system between any number of instruments, up to the maximum of 32 can be made, as shown below:

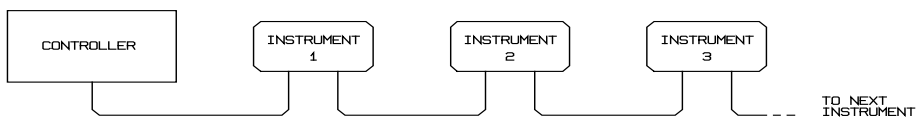

The daisy chain consists of the transmit data (TXD), receive date (RXD) and signal ground lines only. There are no control/handshake lines. This makes XON/XOFF protocol essential and allows the inter-connection between instruments to contain just 3 wires.

The wiring of the adaptor cable is shown below:

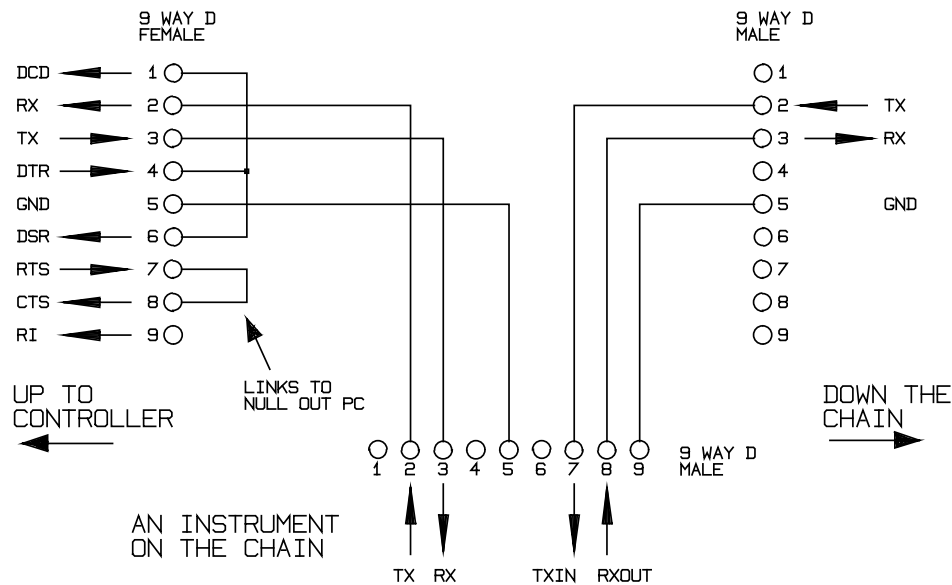

All instruments on the interface must be set to the same baud rate and all must be powered on, otherwise instruments further down the daisy chain will not receive any data or commands.

The other parameters are fixed as follows:

Start Bits: 1	Parity: None
Data Bits: 8	Stop Bits: 1

RS-232 Character Set

Because of the need for XON/XOFF handshake it is possible to send ASCII coded data only; binary blocks are not allowed. Bit 7 of ASCII codes is ignored, i.e. assumed to be low. No distinction is made between upper and lower case characters in command mnemonics and they may be freely mixed. The ASCII codes below 20H (space) are reserved for addressable RS-232 interface control. In this manual 20H, etc. means 20 in hexadecimal

Addressable RS-232 Interface Control Codes

All instruments intended for use on the addressable RS-232 bus use the following set of interface control codes. Codes between 00H and 1FH which are not listed here as having a particular meaning are reserved for future use and will be ignored. Mixing interface control codes inside instrument commands is not allowed except as stated below for CR and LF codes and XON and XOFF codes.

When an instrument is first powered on it will automatically enter the Non-Addressable mode. In this mode the instrument is not addressable and will not respond to any address commands. This allows the instrument to function as a normal RS-232 controllable device. This mode may be locked by sending the Lock Non-Addressable mode control code, 04H. The controller and instrument can now freely use all 8 bit codes and binary blocks but all interface control codes are ignored. To return to addressable mode the instrument must be powered off.

To enable addressable mode after an instrument has been powered on the Set Addressable Mode control code, 02H, must be sent. This will then enable all instruments connected to the addressable RS-232 bus to respond to all interface control codes. To return to Non-Addressable mode the Lock Non-Addressable mode control code must be sent which will disable addressable mode until the instruments are powered off.

Before an instrument is sent a command it must be addressed to listen by sending the Listen Address control code, 12H, followed by a single character which has the lower 5 bits corresponding to the unique address of the required instrument, e.g. the codes A-Z or a-z give the addresses 1-26 inclusive while @ is address 0 and so on. Once addressed to listen the instrument will read and act upon any commands sent until the listen mode is cancelled.

Because of the asynchronous nature of the interface it is necessary for the controller to be informed that an instrument has accepted the listen address sequence and is ready to receive commands. The controller will therefore wait for Acknowledge code, 06H, before sending any commands. The addressed instrument will provide this Acknowledge. The controller should time-out and try again if no Acknowledge is received within 5 seconds.

Listen mode will be cancelled by any of the following interface control codes being received:

- 12H Listen Address followed by an address not belonging to this instrument.
- 14H Talk Address for any instrument.
- 03H Universal Unaddress control code.
- 04H Lock Non-Addressable mode control code.
- 18H Universal Device Clear.

Before a response can be read from an instrument it must be addressed to talk by sending the Talk Address control code, 14H, followed by a single character which has the lower 5 bits corresponding to the unique address of the required instrument, as for the listen address control code above. Once addressed to talk the instrument will send the response message it has available, if any, and then exit the talk addressed state. Only one response message will be sent each time the instrument is addressed to talk.

Talk mode will be cancelled by any of the following interface control codes being received:

- 12H Listen Address for any instrument.
- 14H Talk Address followed by an address not belonging to this instrument.
- 03H Universal Unaddress control code.
- 04H Lock Non-Addressable mode control code.
- 18H Universal Device Clear.

Talk mode will also be cancelled when the instrument has completed sending a response message or has nothing to say.

The interface code 0AH (LF) is the universal command and response terminator; it must be the last code sent in all commands and will be the last code sent in all responses.

The interface code 0DH (CR) may be used as required to aid the formatting of commands; it will be ignored by all instruments. Most instruments will terminate responses with CR followed by LF.

The interface code 13H (XOFF) may be sent at any time by a listener (instrument or controller) to suspend the output of a talker. The listener must send 11H (XON) before the talker will resume sending. This is the only form of handshake control supported by the addressable RS-232 mode.

Full List of Addressable RS-232 Interface Control Codes

- 02H Set Addressable Mode.
- 03H Universal Unaddress control code.
- 04H Lock Non-Addressable mode control code.
- 06H Acknowledge that listen address received.
- 0AH Line Feed (LF); used as the universal command and response terminator.
- 0DH Carriage Return (CR); formatting code, otherwise ignored.
- 11H Restart transmission (XON).
- 12H Listen Address – must be followed by an address belonging to the required instrument.
- 13H Stop transmission (XOFF).
- 14H Talk Address – must be followed by an address belonging to the required instrument.
- 18H Universal Device Clear.

USB Interface

The USB interface allows the instrument to be controlled using RS232 protocol via a computer's USB port. This is useful where the computer's standard RS232 COM ports are fully utilised or non-existent.

The instrument is supplied with a disk containing drivers for various versions of Windows. Any driver updates are available via the TTI website, www.tti-test.com. The disk also contains a text file with information and details of the software installation procedure.

Installation of the interface driver is achieved by connecting the instrument to a PC via a standard USB cable. The Windows' plug and play functions should automatically recognise the addition of new hardware attached to the USB interface and if this is the first time the connection has been made, prompt for the location of a suitable driver. Provided that the standard Windows prompts are followed correctly Windows will install the appropriate driver and establish a virtual COM port within the PC. The number of the new COM port will depend upon the number of co-existing COM ports within the PC. The virtual COM port can be driven by Windows applications in exactly the same way as a standard port.

Note that it is necessary to set the virtual COM port to the same Baud rate as the instrument being controlled in exactly the same way as with a standard RS232 connection.

The driver will remain installed on the PC so that the establishment of a virtual COM port is done automatically each time the instrument is connected to the PC via USB in the future.

Further virtual COM ports are created for each additional instrument connected to the PC via USB. Each instrument is assigned a separate virtual COM port when it is first connected and the same COM port will be assigned each time that instrument is subsequently connected; the PC software makes use of the unique code embedded in each instrument to link it to the same virtual COM port irrespective of which physical USB port it is connected to.

Use can also be made of the ADDRESS? command to easily identify which instrument is being controlled by a particular COM port. Although the addressing capability is ignored in USB operation the address can still be set and used as an identifier; set each USB-connected instrument to a different address and send the ADDRESS? command from each virtual COM port to confirm which instrument is connected to that port.

The supplied disk contains an uninstall program should this be required.

Remote Commands (TG2000 only)

RS-232 Remote Command Formats

Serial input to the instrument is buffered in an input queue which is filled, under interrupt, in a manner transparent to all other instrument operations. The instrument will send XOFF when the queue is nearly full; XON will be subsequently be sent when sufficient space becomes available for more data to be received. This queue contains raw (un-parsed) data which is taken, by the parser, as required. Commands (and queries) are executed in order and the parser will not start a new command until any previous command or query is complete. In non-addressable RS-232 mode responses to commands or queries are sent immediately; there is no output queue. In addressable mode the response formatter will wait indefinitely if necessary, until the instrument is addressed to talk and the complete response message has been sent, before the parser is allowed to start the next command in the input queue.

Commands must be sent as specified in the commands list and must be terminated with the command terminator code 0AH (Line Feed, LF). Commands may be sent in groups with individual commands separated from each other by the code 3BH (;). The group must be terminated with command terminator 0AH (Line Feed, LF).

Responses from the instrument to the controller are sent as specified in the commands list. Each response is terminated by 0DH (Carriage Return, CR) followed by 0AH (Line Feed, LF).

<WHITE SPACE> is defined as character codes 00H to 20H inclusive with the exception of those which are specified as addressable RS-232 control codes.

<WHITE SPACE> is ignored except in command identifiers. e.g. '*C LS' is not equivalent to '*CLS'.

The high bit of all characters is ignored.

The commands are case insensitive.

Each query produces a specific <RESPONSE MESSAGE> which is listed along with the command in the remote commands list.

<WHITE SPACE> is ignored except in command identifiers. e.g. '*C LS' is not equivalent to '*CLS'.

<WHITE SPACE> is defined as character codes 00H to 20H inclusive with the exception of the NL character (0AH).

The high bit of all characters is ignored.

The commands are case insensitive.

Command List

This section lists all commands and queries implemented in this instrument. The commands are listed in alphabetical order within the function groups.

Note that there are no dependent parameters, coupled parameters, overlapping commands, expression program data elements or compound command program headers; each command is completely executed before the next command is started. All commands are sequential and the operation complete message is generated immediately after execution in all cases.

The following nomenclature is used:

- <rmt> <RESPONSE MESSAGE TERMINATOR>
- <cpd> <CHARACTER PROGRAM DATA>, i.e. a short mnemonic or string such as ON or OFF.
- <nrf> A number in any format. e.g. 12, 12.00, 1.2 e 1 and 120 e-1 are all accepted as the number 12. Any number, when received, is converted to the required precision consistent with the use then rounded up to obtain the value of the command.
- <nr1> A number with no fractional part, i.e. an integer.
- [...] Any item(s) enclosed in these brackets are optional parameters. If more than one item is enclosed then all or none of the items are required.

Frequency and Period

These commands set the frequency/period of the generator main output and are equivalent to pressing the **FREQ** key and editing that screen.

WAVFREQ <nrf>	Set the waveform frequency to <nrf> Hz.
WAVPER <nrf>	Set the waveform period to <nrf> sec.

Amplitude and DC Offset

AMPL <nrf>	Set the amplitude to <nrf> in the units as specified by the AMPUNIT command.
AMPUNIT <cpd>	Set the amplitude units to <VPP>, <VRMS> or <DBM>.
ZLOAD <cpd>	Set the output load, which the generator is to assume for amplitude and dc offset entries, to <50> (50Ω), <600> (600Ω) or <OPEN> (hiZ).
ZOUT <cpd>	Set the source impedance to <50> (50Ω) or <600> (600Ω).
DCOFFS <nrf>	Set the dc offset to <nrf> Volts.

Waveform Selection

WAVE <cpd>	Select the output waveform as <SINE>, <SQUARE>, <TRIANG>, <DC>, <+PULSE> or <-PULSE>.
SYMM <nrf>	Sets symmetry to <nrf> %.

Mode Commands

MODE <cpd>	Set the mode to <CONT>, <GATE>, <SWEEP>, <TONE> or <FSK>.
TONEEND <nrf>	Delete tone frequency number <nrf> thus defining the end of the list.
TONEFREQ <nrf1>,<nrf2>	Set tone frequency number <nrf1> to <nrf2> Hz.
FSKFREQ0 <nrf>	Sets FSK frequency 0 to <nrf> Hz
FSKFREQ1 <nrf>	Sets FSK frequency 1 to <nrf> Hz
SWPSTARTFRQ <nrf>	Set the sweep start frequency to <nrf> Hz.
SWPSTOPFRQ <nrf>	Set the sweep stop frequency to <nrf> Hz.
SWPCENTFRQ <nrf>	Set the sweep centre frequency to <nrf> Hz.
SWPSPAN <nrf>	Set the sweep frequency span to <nrf> Hz.
SWPTIME <nrf>	Set the sweep time to <nrf> sec.
SWPTYPE <cpd>	Set the sweep type to <CONT>, <TRIG>, <THLDRST> or <MANUAL>.
SWPDIRN <cpd>	Set the sweep direction to <UP>, <DOWN>, <UPDN> or <DNUP>.
SWPSYNC <cpd>	Set the sweep sync <ON> or <OFF>.
SWPSPACING <cpd>	Set the sweep spacing to <LIN> or <LOG>.
SWPMKR <nrf>	Set the sweep marker to <nrf> Hz.
SWPMANUAL <cpd>	Set the sweep manual parameters to <UP>, <DOWN>, <FINE>, <MEDIUM>, <COARSE>, <WRAPON> or <WRAPOFF>.

Input/Output control

OUTPUT <cpd>	Set the main output <ON>, <OFF>, <NORMAL> or <INVERT>.
AUXOUT <cpd>	Set the aux output <ON>, <OFF>, <AUTO>, <WFMSYNC>, <TRIGGER> or <SWPTRG>
TRIGIN <cpd>	Set the trig input to <INT>, <EXT>, or <MAN>.
TRIGPER <nrf>	Set the internal trigger generator period to <nrf> sec.

Miscellaneous Commands

*IDN?	Returns the instrument identification. The exact response is determined by the instrument configuration and is of the form <NAME>, <model>, 0, <version><rmt>where <NAME> is the manufacturer's name, <MODEL> defines the type of instrument and <VERSION> is the revision level of the software installed.
ADDRESS?	Returns the bus address of the instrument. The syntax of the response is <nr1><rmt>.
EER?	Returns the last error number (in <nr1> format) and message and clears the error register.
*RST	Resets the instrument parameters to their default values (see DEFAULT INSTRUMENT SETTINGS).
*RCL <nrf>	Recalls the instrument set up contained in store number <nrf>. Valid store numbers are 0 – 9. Recalling store 0 sets all parameters to the default settings (see DEFAULT INSTRUMENT SETTINGS).
*SAV <nrf>	Saves the complete instrument set up in the store number <nrf>. Valid store numbers are 1 – 9.
*TRG	This command is the same as pressing the MAN TRIG key. Its effect will depend on the context in which it is asserted.
BEEPMODE <cpd>	Set beep mode to <ON>, <OFF>, <WARN>, or <ERROR>.
BEEP	Sound one beep.
LOCAL	Returns the instrument to local operation and unlocks the keyboard.

Refer to Calibration section for remote calibration commands.

Maintenance

The Manufacturers or their agents overseas will provide a repair service for any unit developing a fault. Where owners wish to undertake their own maintenance work, this should only be done by skilled personnel in conjunction with the service manual which may be purchased directly from the Manufacturers or their agents overseas.

Cleaning

If the instrument requires cleaning use a cloth that is only lightly dampened with water or a mild detergent.

WARNING! TO AVOID ELECTRIC SHOCK, OR DAMAGE TO THE INSTRUMENT, NEVER ALLOW WATER TO GET INSIDE THE CASE. TO AVOID DAMAGE TO THE CASE NEVER CLEAN WITH SOLVENTS.

Appendix 1. Warning and Error Messages

Warning messages are given when a setting may not give the expected result, e.g. DC Offset attenuated by the output attenuator when a small amplitude is set; the setting is, however, implemented.

Error messages are given when an illegal setting is attempted; the previous setting is retained. The last two warning/error messages can be reviewed by selecting **last error** from the UTILITY screen, the latest is reported first.

Warning and error messages are reported with a number on the display; only the number is reported via the remote control interfaces.

The following is a complete list of messages as they appear on the display.

Warning Messages

- | | |
|----|--|
| 00 | No errors or warnings have been reported |
| 10 | DC Offset + level may cause clipping |
| 12 | DC only – setting will have no effect |
| 13 | DC offset changed by amplitude |
| 15 | Symmetry has no effect on this wave |
| 16 | Manual sweep mode not selected |
| 24 | Instrument not calibrated |

Error Messages

- | | |
|-----|--|
| 101 | Frequency too high for triangle wave |
| 102 | Calibration value set to maximum limit |
| 103 | Calibration value set to minimum limit |
| 104 | Number too high – value unchanged |
| 105 | Number too low – value unchanged |
| 106 | Amplitude too high for this waveform |
| 107 | Start freq greater than stop frequency |
| 108 | Stop frequency less than start frequency |
| 109 | Invalid combination of centre and span |
| 110 | Cannot recall memory – contains no data |
| 111 | Trigger period too short for Tone mode. |

Remote Errors

- | | |
|-----|---------------------------------------|
| 126 | Illegal store number requested |
| 164 | Command illegal in selected mode |
| 167 | dBm output units assume a termination |
| 173 | Illegal tone number |
| 177 | Illegal remote calibration command. |
| 255 | Remote command syntax error. |

Appendix 2. Factory System Defaults

The factory system defaults are listed in full below. They can be recalled by pressing `recall...` on the UTILITIES menu followed by `set defaults` by the remote command `*RST`.

Main Parameters

Std. Wave:	Sine	
Frequency:	10kHz	
Output:	+4.0Vpp	; Output Off
DC Offset:	0V	
Zout:	HiZ	

Gate/Trigger Parameters

Source:	Internal
Period:	1ms

Sweep Parameters

Start Frequency:	100kHz
Stop Frequency:	20MHz [10MHz]
Marker Frequency:	10MHz [5MHz]
Direction:	Up
Spacing:	Log
Sweep Time:	50ms
Type:	Continuous

AUX Out

Output:	On
Mode:	Auto
Source:	Waveform sync



Thurlby Thandar Instruments Ltd.

Glebe Road • Huntingdon • Cambridgeshire • PE29 7DR • England (United Kingdom)

Telephone: +44 (0)1480 412451 • Fax: +44 (0)1480 450409

International web site: www.tti-test.com • UK web site: www.tti.co.uk

Email: info@tti-test.com