



THURLBY THANDAR INSTRUMENTS

TG5011 & TG2511

Function/Arbitrary Generators

INSTRUCTION MANUAL



Table of Contents

Introduction	2
Specification	3
Safety	10
EMC	12
Installation	13
Connections	14
General	16
Continuous Carrier Waveform Operation	20
Pulse Generator	26
Noise Generator	29
Modulation	31
Sweep	42
Burst	47
Utility Menus	50
Stores Menu	57
Help Operations	65
Editing Arbitrary Waveforms	66
Synchronising Two Generators	70
Calibration	72
Remote Interface Operation	76
Remote Commands	83
Remote Commands Summary	90
Appendix 1. Information, Warning and Error Messages	94
Appendix 2. Factory Default Settings	102
Appendix 3. Waveform Manager Plus V4 Arbitrary Waveform Creation Software	104
Maintenance	105

Introduction

This manual is for both the TG5011 and TG2511 generators. Wherever there are differences in the specification, the limits for the TG2511 are shown in square brackets [] after the TG5011 limits.

These new programmable function/arbitrary generators use direct digital synthesis techniques to provide high performance and extensive facilities in a compact instrument. They can generate a wide variety of waveforms between 1 μ Hz and 50MHz [25MHz] with high resolution and accuracy.

Sine waves are produced with low distortion to 50MHz [25MHz]. Square waves have fast rise and fall times at up to 50MHz [25MHz]. Linear ramp waves are produced to 500kHz [250kHz]. Ramp and square waves also have variable symmetry.

The instruments can generate variable edge time pulses to 12.5MHz [6.25MHz] with variable period, pulse width, delay and amplitude.

Complex custom waveforms can be generated with 14-bit resolution and a sampling rate of 125MSa/s. Up to four waveforms can be stored in non-volatile memory.

Waveforms can also be generated by the supplied Waveform Manager Plus Version 4 Windows application and downloaded to the instrument via USB, LAN or optional GPIB interfaces or via a USB flash drive.

Front panel operation is straightforward and user friendly with all major parameters shown at all times on the large bright LCD. All major functions can be accessed with a single key or two. The knob or numeric keypad can be used to adjust frequency, amplitude, offset, and other parameters. Voltage values can be entered directly in Vpp, Vrms, dBm, or as high and low levels. Timing parameters can be entered in Hertz (Hz) or seconds.

Internal AM, FM, PM, FSK, and PWM modulation make it easy to modulate waveforms without the need for a separate modulation source. Linear and logarithmic sweeps are also built in, with sweep rates selectable from 1 ms to 500s. Burst mode operation allows for a user-selected number of cycles at each trigger event.

LAN and USB interfaces are standard and there is full compliance to LXI Class C specification.

The instruments use a high stability temperature compensated internal oscillator and the external frequency reference input lets you synchronize to an external 10 MHz frequency standard for even greater accuracy.

- Sine waves up to 50MHz [25MHz], square waves up to 50MHz [25MHz]
- 16 standard waveforms available plus pulse, noise and arbitrary
- User defined pulses with 10ns resolution
- 14 bit resolution arbitrary waveforms with 125MHz sampling frequency
- Up to 4 arbitrary waveforms of 2 to 128k points.
- Fully compliant to LXI Class C specification
- AM, FM, PM, FSK, and PWM modulation types
- Linear & logarithmic sweeps
- 3 burst types; Gated, Counted and Infinite
- 10 mVpp to 10 Vpp amplitude range (into 50 Ω)
- Independent variable rise and fall adjustment
- Visual representation of the output waveform shown at all times on the LCD
- Connect via USB and LAN
- USB host port for connection of USB flash drives for waveform and set-up storage

Specification

General specifications apply for the temperature range 5°C to 40°C. Accuracy specifications apply for the temperature range 18°C to 28°C after 30 minutes warm-up, at maximum output into 50Ω. Typical specifications are determined by design and are not guaranteed.

TG2511 limits, where different, are shown in square brackets [] after the TG5011 limits.

Waveforms

Standard Waveforms

Sine, Square, Ramp (Variable Symmetry), Triangle, Positive Ramp, Negative Ramp, Pulse, Noise (Gaussian), DC, Sin(x)/x, Exponential Rise, Exponential Fall, Logarithmic Rise, Logarithmic Fall and 4 User Defined Arbitrary Waveforms. Haversine, Gaussian, Lorentz and Cardiac are supplied on CD.

Sine

Frequency Range:	1μHz to 50MHz [1μHz to 25MHz]		
Frequency Resolution:	1μHz, 14 digits		
Output Level:	10mVp-p to 10Vp-p into 50Ω		
Amplitude Flatness (Relative to 1kHz):	<100kHz	0.1dB	
	<5MHz	0.15dB	
	<25MHz	0.3dB	
	<50MHz	0.5dB	
Harmonic Distortion:		<1 Vp-p	≥ 1Vp-p
	DC to 20kHz	-65dBc	-65dBc
	20kHz to 100kHz	-60dBc	-60dBc
	100kHz to 1MHz	-45dBc	-45dBc
	1MHz to 25MHz	-40dBc	-35dBc
	25MHz to 50MHz	-40dBc	-28dBc
Non-Harmonic Spuri:	<-60dBc to 1MHz, <-60dBc + 6dB/octave 1MHz to 50MHz		
Phase Noise (10kHz offset):	-115dBc/Hz, typical		

Square

Frequency Range:	1μHz to 50MHz [1μHz to 25MHz]		
Frequency Resolution:	1μHz, 14 digits		
Output Level:	10mVp-p to 10Vp-p into 50Ω		
Rise and Fall Times:	<8ns [<13ns]		
Overshoot:	<5%		
Variable Duty Cycle:	20% to 80% to 10MHz, 0.1% resolution		
	40% to 60% to 25 MHz, 0.1% resolution		
	50% (fixed) above 25MHz		
Asymmetry (@ 50% duty):	1% of period + 5ns		
Jitter (RMS):	0.5ns + 100 ppm of period, typical		

Ramp

Frequency Range:	1 μ Hz to 500kHz [1 μ Hz to 250kHz]
Frequency Resolution:	1 μ Hz, 12 digits
Output Level:	10mVp-p to 10Vp-p into 50 Ω
Linearity Error:	<0.1% to 30 kHz
Variable Symmetry:	0.0 % to 100.0 %, 0.1% resolution

Pulse

Frequency Range:	500 μ Hz to 12.5MHz [500 μ Hz to 6.25MHz]
Frequency Resolution:	1 μ Hz , 14 digits
Output Level:	10mVp-p to 10Vp-p into 50 Ω
Overshoot:	<5%
Jitter:	300ps + 0.01% of period, typical
Rise/Fall Times:	Rise and Fall times can be independently varied or can be varied together simultaneously.
Range:	<8ns to 40 μ s [<13ns to 40 μ s]
Resolution:	0.1ns (for rise and fall time \leq 100ns) 1ns (for rise and fall time >100ns and \leq 2 μ s) 10ns (for rise and fall time >2 μ s and \leq 40 μ s)
Width Range:	20ns to 2000s (20ns min for period \leq 40s; 200 ns min for period >40s and \leq 400s; 2 μ s min for period >400s)
Width Resolution:	10ns (for period \leq 40s) 100ns (for period >40s and \leq 400s) 1 μ s (for period >400s)
Delay Range:	0ns to 2000s
Delay Resolution:	10ns (for period \leq 40s) 100ns (for period >40s and \leq 400s) 1 μ s (for period >400s)

Arbitrary

In built arbitrary waveforms (Sinc, Exponential Rise, Logarithmic Rise and DC). Up to 4 user-defined waveforms may be stored in non-volatile memory. Waveforms can be defined by downloading of waveform data via remote interfaces or from the instrument's front panel.

Waveform Memory Size:	4 waveforms – 4 waveforms of maximum size 65536 points or 3 waveforms – 1 waveform of maximum size 131072 points and 2 waveforms of maximum size 65536 points or 2 waveforms – 2 waveforms of maximum size 131072 points. Minimum waveform size is 2 points.
Vertical Resolution:	14 bits
Frequency Range:	1 μ Hz to 10MHz [1 μ Hz to 6MHz]
Frequency Resolution:	1 μ Hz, 14 digits
Output Level:	10mVp-p to 10Vpp into 50 Ω
Sampling rate:	125MS/s

Output Filter

Selects between 50MHz Elliptic or 20MHz Bessel filter depending on the waveform.

Noise

Gaussian White Noise: Noise can be added to any carrier waveform (except pulse and square and noise itself). The amount of noise added can be specified as 0% to 50% of the amplitude of the carrier waveform. Noise can also be used as modulating waveform.

Bandwidth (-3dB):	20MHz typical
Noise crest factor (Vp/Vrms):	5.27
Output Level:	10mVp-p to 10Vpp into 50Ω

Internal Frequency Reference

Initial Setting Error:	<± 2ppm
Oscillator Ageing Rate:	<± 1ppm first year
Temperature Stability:	<1ppm over the specified temperature range

Modulation

AM

Carrier Waveforms:	Sine, Square, Ramp, Arb
Modulation Source:	Internal/External
Internal Modulating Waveforms:	Sine, Square, Up Ramp, Down Ramp, Triangle, Noise, DC, Sinc, Exponential Rise, Logarithmic Rise and User Defined Arbs
Internal Modulating Frequency:	1μHz to 20kHz, 1μHz resolution
Amplitude Depth:	0.0% to 120.0%, 0.1% resolution

FM

Carrier Waveforms:	Sine, Square, Ramp, Arb
Modulation Source:	Internal/External
Internal Modulating Waveforms:	Sine, Square, Up Ramp, Down Ramp, Triangle, Noise, DC, Sinc, Exponential Rise, Logarithmic Rise and User Defined Arbs
Internal Modulating Frequency:	1μHz to 20kHz, 1μHz resolution
Frequency Deviation:	DC to Fmax/2, 1μHz resolution

PM

Carrier Waveforms:	Sine, Square, Ramp, Arb
Modulation Source:	Internal/External
Internal Modulating Waveforms:	Sine, Square, Up Ramp, Down Ramp, Triangle, Noise, DC, Sinc, Exponential Rise, Logarithmic Rise and User Defined Arbs
Internal Modulating Frequency:	1μHz to 20kHz, 1μHz resolution
Phase Deviation:	-360.0 to +360.0 degrees, 0.1 degree resolution

PWM

Carrier Waveforms:	Pulse
Modulation Source:	Internal/External
Internal Modulating Waveforms:	Sine, Square, Up Ramp, Down Ramp, Triangle, Noise, DC, Sinc, Exponential Rise, Logarithmic Rise and User Defined Arbs
Internal Modulating Frequency:	1 μ Hz to 20kHz, 1 μ Hz resolution
Pulse Width Deviation:	0% to 100% of pulse width, resolution same as of pulse width

FSK

Carrier Waveforms:	Sine, Square, Ramp, Arb
Source:	Internal/External (via TRIG IN)
Internal Modulation:	50% duty cycle square (2mHz to 100kHz)

Triggered Burst

Each active edge of the trigger signal will produce one burst of the waveform.

Carrier Waveforms:	Sine, Square, Ramp, Arb, Pulse
Maximum Carrier Frequency:	10MHz (finite cycles), 50MHz [25MHz] (infinite), subject to carrier waveform.
Number of Cycles:	1 to 1,048,575 and infinite.
Trigger Repetition Rate:	2mHz to 1MHz internal dc to 1MHz external.
Trigger Signal Source:	Internal from keyboard or trigger generator. External from TRIG IN or remote interface.
Trigger Start/Stop Phase:	-360.0 to +360.0 degrees, 0.1 degree resolution, subject to carrier waveform

Gated

Waveform will run while the Gate signal is true and stop while false.

Carrier Waveforms:	Sine, Square, Ramp, Arb, Pulse, Noise
Maximum Carrier Frequency:	10 MHz, subject to carrier waveform
Trigger Repetition Rate:	2mHz to 1MHz internal dc to 1MHz external.
Gate Signal Source:	Internal from keyboard or trigger generator. External from TRIG IN or remote interface.
Gate Start/Stop Phase:	-360.0 to +360.0 degrees, 0.1 degree resolution, subject to carrier waveform

Sweep

Frequency sweep capability is provided for both standard and arbitrary waveforms.

Carrier Waveforms:	All standard and arbitrary except pulse.
Sweep Mode:	Linear or logarithmic, triggered or continuous.
Sweep Direction:	Up, down, up/down or down/up.
Sweep Range:	From 1 μ Hz to 50MHz [25MHz], subject to carrier waveform. Phase continuous. Independent setting of the start and stop frequency.
Sweep Time:	1ms to 500s (6 digit resolution).
Marker:	Variable during sweep.
Sweep Trigger Source:	The sweep may be free run or triggered from the following sources: Internal from keyboard or trigger generator. Externally from TRIG IN input or remote interface.

Trigger Generator

Internal source 2mHz to 1MHz square wave adjustable in 1us steps, 9 digit resolution. Available for external use from the SYNC OUT socket.

Outputs

Main Output

Output Impedance:	50 Ω
Amplitude:	20mV to 20Vp-p open circuit (10mV to 10Vp-p into 50 Ω). Amplitude can be specified open circuit (hi Z) or into an assumed load of 1 Ω to 10k Ω in Vpp, Vrms or dBm.
Amplitude Accuracy:	2% \pm 1mV at 1kHz into 50 Ω .
DC Offset Range:	\pm 10V. DC offset plus signal peak limited to \pm 10V from 50 Ω .
DC Offset Accuracy:	Typically 3% \pm 10mV.
Resolution:	3 digits or 1mV for both Amplitude and DC Offset.

Sync Out

Multifunction output user definable or automatically selected to be any of the following:

Carrier Waveform Sync:	Sine/Ramp/ Pulse	A square wave with 50% duty cycle at the waveform frequency.
	Square	A square wave with same duty cycle as the main output at the waveform frequency.
	Arbs	A square wave with 50% duty cycle at the waveform frequency. The sync is a TTL high when the first point of the waveform is output.
	Noise	No sync associated with noise.

Modulation Sync:	AM/FM/PM/ PWM	A square wave with 50% duty cycle referenced to the internal modulation waveform when modulation source is internal, or a square wave referenced to the carrier waveform when modulation source is external. No sync is associated with noise as the modulation source.
	FSK	A square wave referenced to the trigger rate. The sync is a TTL high when hop frequency is the output frequency and TTL low when carrier frequency is the output frequency for positive slope and vice versa for negative slope.
Burst Sync:		A square wave that is a TTL high when the burst begins and a TTL low when burst is completed.
Trigger:		Selects the current trigger signal. Useful for synchronizing burst or gated signals.
Sweep Sync:	Marker Off	A square wave that is a TTL high from the beginning of the sweep and a TTL low from the midpoint of the sweep
	Marker On	A square wave that is a TTL high from the beginning of the sweep and a TTL low from the marker frequency
Output Signal Level:		Logic level nominally 3V.

Ref Clock Output

Buffered version of the 10MHz clock currently in use (internal or external)

Output Level: Nominally 3V logic level from 50Ω.

Inputs

Trig In

Frequency Range: DC – 1MHz.

Signal Range: Threshold nominally TTL level; maximum input ±10V.

Minimum Pulse Width: 50ns

Polarity: Selectable as high/rising edge or low/falling edge.

Input Impedance: 10kΩ

External Modulation Input (for AM, FM, PM, PWM)

Voltage Range: ± 5V full scale

Input Impedance: 5kΩ typical

Bandwidth: DC to 20kHz

Ref Clock Input

Input for an external 10MHz reference clock

Voltage Range: 1Vpp – 5Vpp

Maximum Voltage: +5V

Minimum Voltage: -1V

Phase Synchronising Two Generators

Two generators can be synchronised together to provide outputs at the same frequency (or harmonics) and with a phase difference. The amplitude and phase of these outputs can also be modulated providing the capability to perform QAM and QPSK respectively. It is also possible to synchronise more than two generators but results are not guaranteed.

Carrier Waveforms:	Sine, Square, Ramp, Arb, Pulse	
Phase:	Range	-360.0 to +360.0 degrees
	Resolution	0.1 degree
	Accuracy	< ±5ns

Interfaces

Full digital remote control facilities are available through LAN and USB interfaces.

LAN Interface	Ethernet 100/10base – T hardware connection. LXI V1.2, Class C compliant.
USB Interface	Standard USB 2.0 hardware connection. Implemented as virtual-COM port.
USB Flash Drive	For waveform and set-up storage/recall.

General

Display:	256 x 112 pixel monochrome graphics display. White LED backlight with adjustable brightness and contrast. Black-on-white or inverse modes.
Data Entry:	Keyboard selection of mode, waveform etc.; value entry direct by numeric keys or by rotary control.
Stored Settings:	Up to 9 complete instrument set-ups may be stored and recalled from non-volatile memory.
Size:	Bench Top: 97mm height; 250mm width; 270mm long
	Rack mount: 86.5mm (2U) height; 213.5mm (½-rack) width; 244mm long.
Weight:	2.55 kg
Power:	110-240VAC ±10% 50/60Hz; 100-120VAC ±10% 400Hz; 60VA max. Installation Category II.
Operating Range:	+5°C to 40°C, 20–80% RH.
Storage Range:	–20°C to + 60°C.
Environmental:	Indoor use at altitudes up to 2000m, Pollution Degree 2.
Options:	19 inch rack mounting kit.
Safety:	Complies with EN61010–1.
EMC:	Complies with EN61326

This generator is a Safety Class I instrument according to IEC classification and has been designed to meet the requirements of EN61010–1 (Safety Requirements for Electrical Equipment for Measurement, Control and Laboratory Use). It is an Installation Category II instrument intended for operation from a normal single phase supply.

This instrument has been tested in accordance with EN61010–1 and has been supplied in a safe condition. This instruction manual contains some information and warnings which have to be followed by the user to ensure safe operation and to retain the instrument in a safe condition.

This instrument has been designed for indoor use in a Pollution Degree 2 environment in the temperature range 5°C to 40°C, 20% – 80% RH (non–condensing). It may occasionally be subjected to temperatures between +5° and –10°C without degradation of its safety. Do not operate while condensation is present.

Use of this instrument in a manner not specified by these instructions may impair the safety protection provided. Do not operate the instrument outside its rated supply voltages or environmental range.

WARNING! THIS INSTRUMENT MUST BE EARTHED

Any interruption of the mains earth conductor inside or outside the instrument will make the instrument dangerous. Intentional interruption is prohibited. The protective action must not be negated by the use of an extension cord without a protective conductor.

When the instrument is connected to its supply, terminals may be live and opening the covers or removal of parts (except those to which access can be gained by hand) is likely to expose live parts. The apparatus shall be disconnected from all voltage sources before it is opened for any adjustment, replacement, maintenance or repair.

Any adjustment, maintenance and repair of the opened instrument under voltage shall be avoided as far as possible and, if inevitable, shall be carried out only by a skilled person who is aware of the hazard involved.

If the instrument is clearly defective, has been subject to mechanical damage, excessive moisture or chemical corrosion the safety protection may be impaired and the apparatus should be withdrawn from use and returned for checking and repair.

Make sure that only fuses with the required rated current and of the specified type are used for replacement. The use of makeshift fuses and the short–circuiting of fuse holders is prohibited.

This instrument uses a Lithium button cell for non–volatile memory battery back–up; typical life is 5 years. In the event of replacement becoming necessary, replace only with a cell of the correct type, i.e. 3V Li/MnO₂ 20mm button cell type 2032. Exhausted cells must be disposed of carefully in accordance with local regulations; do not cut open, incinerate, expose to temperatures above 60°C or attempt to recharge.

Do not wet the instrument when cleaning it and in particular use only a soft dry cloth to clean the LCD window. The following symbols are used on the instrument and in this manual:–



Caution –refer to the accompanying documentation, incorrect operation may damage the instrument.



terminal connected to chassis ground.



mains supply OFF.



mains supply ON.



alternating current.

EC Declaration of Conformity

We Thurlby Thandar Instruments Ltd
Glebe Road
Huntingdon
Cambridgeshire PE29 7DR
England

declare that the

TG5011 and TG2511 Function Arbitrary Generators

meet the intent of the EMC Directive 2004/108/EC and the Low Voltage Directive 2006/95/EC. Compliance was demonstrated by conformance to the following specifications which have been listed in the Official Journal of the European Communities.

EMC

Emissions: a) EN61326-1 (2006) Radiated, Class A
 b) EN61326-1 (2006) Conducted, Class B
 c) EN61326-1 (2006) Harmonics, referring to EN61000-3-2 (2006)

Immunity: EN61326-1 (2006) Immunity Table 1, referring to:
 a) EN61000-4-2 (1995) Electrostatic Discharge
 b) EN61000-4-3 (2006) Electromagnetic Field
 c) EN61000-4-11 (2004) Voltage Interrupt
 d) EN61000-4-4 (2004) Fast Transient
 e) EN61000-4-5 (2006) Surge
 f) EN61000-4-6 (2007) Conducted RF
Performance levels achieved are detailed in the user manual.

Safety

EN61010-1 Installation Category II, Pollution Degree 2.

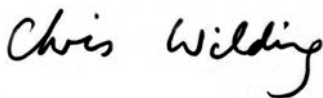

CHRIS WILDING
TECHNICAL DIRECTOR

1 March 2010

This instrument has been designed to meet the requirements of the EMC Directive 2004/108/EC. Compliance was demonstrated by meeting the test limits of the following standards:

Emissions

EN61326-1 (2006) EMC product standard for Electrical Equipment for Measurement, Control and Laboratory Use. Test limits used were:

- a) Radiated: Class A
- b) Conducted: Class B
- c) Harmonics: EN61000-3-2 (2006) Class A; the instrument is Class A by product category.

Immunity

EN61326-1 (2006) EMC product standard for Electrical Equipment for Measurement, Control and Laboratory Use.

Test methods, limits and performance achieved are shown below (requirement shown in brackets):

- a) EN61000-4-2 (1995) Electrostatic Discharge : 4kV air, 4kV contact, Performance A (B).
- b) EN61000-4-3 (2006) Electromagnetic Field:
3V/m, 80% AM at 1kHz, 80MHz – 1GHz: Performance A (A) and 1.4GHz to 2GHz:
Performance A (A); 1V/m, 2.0GHz to 2.7GHz: Performance A (A).
- c) EN61000-4-11 (2004) Voltage Interrupt: ½ cycle and 1 cycle, 0%: Performance A (B);
25 cycles, 70%: Performance A(C); 250 cycles, 0%: Performance B (C).
- d) EN61000-4-4 (2004) Fast Transient: 1kV peak (AC line), (AC line only; signal
connections <3m, therefore not tested), Performance A (B).
- e) EN61000-4-5 (2006) Surge: 0.5kV (line to line), 1kV (line to ground), Performance A (B).
- f) EN61000-4-6 (2007) Conducted RF, 3V, 80% AM at 1kHz (AC line only; signal
connections <3m, therefore not tested), Performance A (A).

According to EN61326-1 the definitions of performance criteria are:

Performance criterion A: 'During test normal performance within the specification limits.'

Performance criterion B: 'During test, temporary degradation, or loss of function or performance which is self-recovering'.

Performance criterion C: 'During test, temporary degradation, or loss of function or performance which requires operator intervention or system reset occurs.'

Cautions

To ensure continued compliance with the EMC directive observe the following precautions:

- a) Connect the generator to other equipment using only high quality, double-screened cables. For the purposes of EMC testing it is assumed that signal connections from the instrument will be <3m and therefore immunity tests for signal lines (Fast Transient and Conducted RF) have been omitted.
- b) After opening the case for any reason ensure that all signal and ground connections are remade correctly and that case screws are correctly refitted and tightened.
- c) In the event of part replacement becoming necessary, only use components of an identical type, see the Service Guide.

Mains Operating Voltage

This instrument has a universal input range and will operate from a nominal 115V or 230V mains supply without adjustment. Check that the local supply meets the AC input requirement given in the Specification.

Mains Lead

Connect the instrument to the AC supply using the mains lead provided. Should a mains plug be required for a different mains outlet socket, a suitably rated and approved mains lead set should be used which is fitted with the required wall plug and an IEC60320 C13 connector for the instrument end. To determine the minimum current rating of the lead-set for the intended AC supply, refer to the power rating information on the equipment or in the Specification.

WARNING! THIS INSTRUMENT MUST BE EARTHED.

Any interruption of the mains earth conductor inside or outside the instrument will make the instrument dangerous. Intentional interruption is prohibited.

Mounting

This instrument is suitable both for bench use and rack mounting. It is delivered with soft protective front and rear bezels which have integral moulded feet; this is the most suitable configuration for bench use.

For rack mounting the protective bezels and handle/stand can be removed such that the instrument can be fitted beside any other standard 2U half-rack instrument in a 19" rack. A suitable 2U 19" rack kit is available from the Manufacturers or their overseas agents; full details of how to remove the handle and bezels are included with the kit.

Ventilation

The generator uses a small fan fitted to the rear panel. Take care not to restrict the rear air exit or the inlet vents at the front (sides and underneath). In rack-mounted situations allow adequate space around the instrument and/or use a fan tray for forced cooling.

Handle/stand

The instrument is fitted with a 4-position handle/stand. Pull out both sides of the handle at the case pivot points, to free the position locking pegs, and rotate the handle from the stowed position to the required stand or handle position. Release the sides of the handle to lock it in the new position.

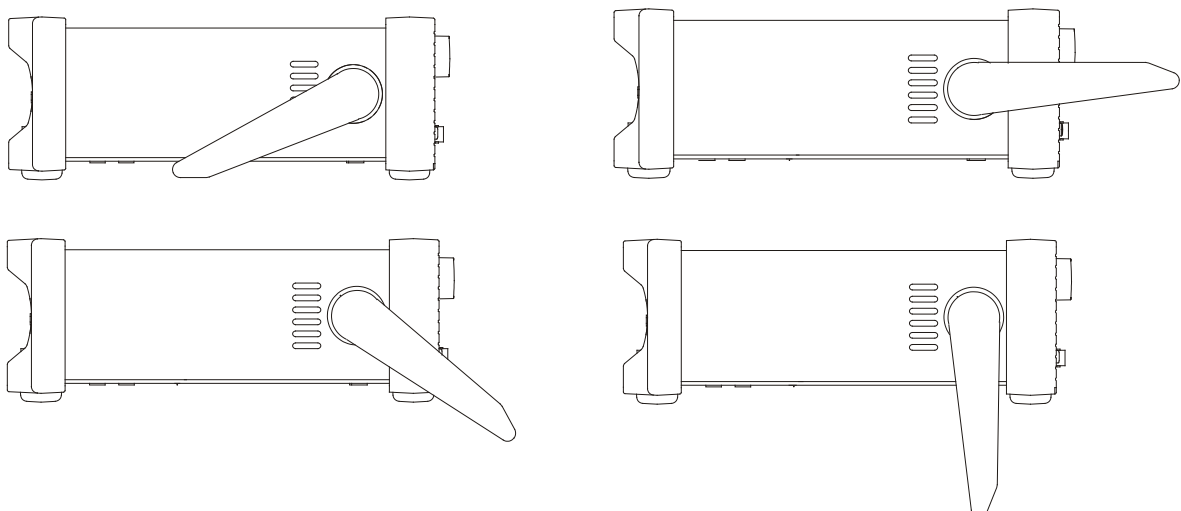

Front Panel Connections

MAIN OUT

This is the 50Ω output from main generator. It will provide up to 20V peak-to-peak e.m.f. which will yield 10V peak-to-peak into a matched 50Ω load. To maintain waveform integrity only 50Ω cable should be used and the receiving end should be terminated with a 50Ω load. It can tolerate a short circuit for 60 seconds.



Do not apply an external voltage to this output.

SYNC OUT

Multifunction output which is user definable or automatically set to be any of the following:

Carrier Waveform Sync:	Sine/Ramp/ Pulse	A square wave with 50% duty cycle at the waveform frequency.
	Square	A square wave with same duty cycle as the main output at the waveform frequency.
	Arbs	A square wave with 50% duty cycle at the waveform frequency. The sync is a TTL high when the first point of the waveform is output.
	Noise	No sync output is associated with noise.
Modulation Sync:	AM/FM/PM/ PWM	A square wave with 50% duty cycle referenced to the internal modulation waveform when modulation source is internal, or a square wave referenced to the carrier waveform when modulation source is external. No sync is associated with noise as the modulation source.
	FSK	A square wave referenced to the trigger rate. The sync is a TTL high when hop frequency is the output frequency and TTL low when carrier frequency is the output frequency for positive slope and vice versa for negative slope.
Burst Sync:		A square wave that is a TTL high when the burst begins and a TTL low when burst is completed.
Trigger:		Selects the current trigger signal. Useful for synchronizing burst or gated signals.
Sweep Sync:	Marker Off	A square wave that is a TTL high from the beginning of the sweep and a TTL low from the midpoint of the sweep
	Marker On	.A square wave that is a TTL high from the beginning of the sweep and a TTL low from the marker frequency
Output Signal Level:		Logic level nominally 3V.



Do not apply an external voltage to this output.

FLASH DRIVE

This is a USB Host port for the connection of most types of flash drive which conform to the Mass Storage Class specification. The instrument will accept drives formatted with the FAT16 or FAT32 filing systems. This port does not support any other class of device.

Rear Panel Connections

MOD IN

This is the external modulation input socket for AM, FM, PM or PWM. Full-scale input is $\pm 5V$, frequency DC to 20kHz.



Do not apply an external voltage exceeding $\pm 5V$.

10MHz REF IN

Input for an external 10MHz reference clock. Input range 1Vpp – 5Vpp.



Do not apply external voltages exceeding + 5V or –1V to this signal connection.

10MHz REF OUT

Buffered version of the 10MHz clock currently in use (internal or external). Output level nominally 3V logic from 50 Ω .



Do not apply external voltages to this output.

TRIG IN

This is the external input for Trigger, Gate and Sweep operations. It is also the input used to synchronise the generator (as a slave) to another (which is the master).



Do not apply an external voltage exceeding $\pm 10V$.

LAN

The LAN interface is designed to meet LXI (Lan eXtensions for Instrumentation) version 1.2; the instrument is Class C compliant. Remote control using the LAN interface is possible using the TCP/IP Socket protocol. The instrument also contains a basic Web server which provides information on the unit and allows it to be configured. Since it is possible to misconfigure the LAN interface, making it impossible to communicate with the instrument over LAN, a LAN Configuration Initialise (LCI) mechanism is provided via the user interface to reset the unit to the factory default.

Further details are given in the Remote Operation chapter. For more information on LXI standards refer to www.lxistandard.org/home

USB

The USB port is connected to instrument ground. It accepts a standard USB cable. If the USB driver has been installed from the CD, the Windows plug-and-play function should automatically recognise that the instrument has been connected. See the USB folder on the CD for information on installing the driver on a PC.

GPIB (IEEE–488) - optional

The GPIB interface is not isolated; the GPIB signal grounds are connected to the instrument ground.

The implemented subsets are:

SH1 AH1 T6 TE0 L4 LE0 SR1 RL1 PP1 DC1 DT1 C0 E2

The default GPIB address is 5.

Initial Operation

This section is a general introduction to the organisation of the instrument and is intended to be read before using the generator for the first time. Detailed operation is covered in later sections starting with Continuous Carrier Waveform Operation.

In this manual front panel keys and sockets are shown in capitals, e.g. SWEEP, SYNC OUT; all soft-key labels, entry fields and messages displayed on the LCD are shown in a different type-font, e.g. **Offset**, **Sine**.

Where, for example, **ARB-Load-BuiltIn2-Square** appears it means press the specified keys in order. In this case press the ARB key then the **Load** soft-key then the **BuiltIn2** soft-key then the **Square** soft-key

Switching On

The power switch is located at the bottom left of the front panel. To fully disconnect from the AC supply unplug the mains cord from the back of the instrument or switch off at the AC supply outlet; make sure that the means of disconnection is readily accessible. Disconnect from the AC supply when not in use.

At power up the generator displays a start-up message whilst initialising the application; if an error is encountered the message

Firmware Update / Battery Fail. Initialised to factory default state.

will be displayed, see the Warnings and Error Messages section.

Loading takes a few seconds, after which the carrier waveform set-up screen is displayed, showing the generator parameters set to their default values, with the MAIN OUT output set off. Refer to the Utility Operations section for how to change the power up settings to either those at power down or to the defaults.

Change the basic generator parameters as described in the Continuous Carrier Waveform Operation section and switch the output on with the OUTPUT key; the key will glow green to show that the output is on.

Keyboard

The front panel contains the liquid crystal display (LCD) and the keyboard which are used together to control all instrument functions.

The keys are grouped as follows:

- Six soft keys under the display. The function of these keys change as the instrument is operated. The current function is shown on the LCD in a box above each key. An empty box means that the key currently has no function.
- Numeric keys permit direct entry of a value for the parameter currently selected.
- Six keys under the soft keys select the carrier waveform from SINE, SQUARE, RAMP, PULSE, NOISE and ARB. The selected key glows green. Selecting any of these waveforms will cancel the previously selected waveform.
- Three keys to select the operating mode from MOD (modulation), SWEEP and BURST. The selected key glows yellow. If all keys are unlit the mode will be continuous carrier wave.
- The OUTPUT key simply switches the MAIN OUT on or off. Glows green when the output is on.
- TRIGGER key. Used to issue a manual trigger signal.
- UTILITY key gives access to menus for a variety of functions such as SYNC OUT set-up, power-up parameters and error message settings.
- STORES key allows access to the built in storage for waveforms and set-ups and to a connected flash drive.

- KNOB and left and right cursor keys. Used during numeric entry. The left and right keys move the edit position left or right and the knob increments or decrements the value of the selected digit.
- The HELP/ LOCAL key gives direct access to the complete help system. However, context sensitive help can be obtained for any key, including soft-keys, by holding the key down for 2 seconds. This key is also used to return to local from remote mode.

Further explanations will be found in the detailed descriptions of the generator's operation.

Display

All parameter settings are displayed on the 256 x 112 pixel backlit liquid crystal display (LCD). The most common type of display layout is shown below:

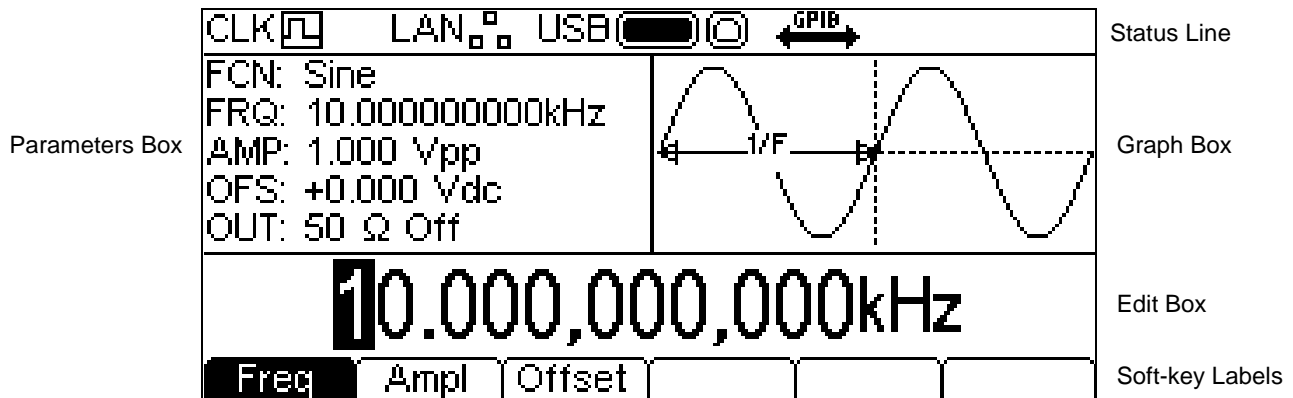

The Status Line indicates the interface status of the instrument as follows:

- The **CLK** field indicates which clock source the instrument is using. As shown, the clock source is internal. If the source is external the field will change to **CLK** with an external source icon.
- The **LAN** field indicates the status of the Local Area Network interface. As shown, there is no LAN connection. When connected the field will change to **LAN** with a network icon. While a connection is being established the indicator will flash. If the Lan is connected but not enabled the field will show as **LAN** with a network icon and a slash.
- The **USB** field indicates the status of the two USB ports. The left icon is the flash drive and the right icon is the device port for instrument remote control. As shown there is a flash drive inserted but the device port is idle. With the device active the field will show **USB** with both icons. Activity on either port will cause the corresponding icon to flash.
- The **GPIB** Field shows the GPIB port status. As shown, the port is disabled. When the port is enabled the field will show **GPIB** with a double-headed arrow. During GPIB remote control the icon will flash. If GPIB is not fitted to the instrument the field will be blank.
- The area on the extreme right will show **REM** when the instrument is in remote state with the keyboard locked. To regain keyboard control press the LOCAL key.

Below the Status Line are two boxes which show how the instrument is currently operating.

- The Parameters Box on the left shows the settings of all the carrier waveform parameters. These include **FCN** (function), **FRQ** (frequency), **AMP** (amplitude), **OFS** (offset) and **OUT** (output state). This information will be updated as the parameters are edited. While any of the modes, for example Sweep, are being edited the fields will temporarily change to show the additional parameters for that mode. See the respective sections on mode editing.
- The Graph Box on the right shows a representation of the waveform which the instrument is generating. The parameter currently being edited is indicated by arrows.

The lower part of the display contains the Edit Box which shows the value of the parameter currently being edited. This will be a numeric value or a parameter string.

Under the Edit Box are the current Soft-key Labels which change as editing proceeds.

The Status Line and the Soft-key Labels are always shown on the LCD. The section between these areas will sometimes change in appearance, for example when displaying help.

A Pop-up Box may also appear to provide error or warning messages or to give other information to the user. See Appendix 1: Information, Warning and Error Messages for a full list of messages.

Editing Principles

The instrument parameters are edited using the keyboard in conjunction with the Soft-key Labels and the Edit Box.

Generally, the required parameter is selected by pressing waveform keys, modulation keys or soft-keys or a combination of these to show the parameter in the Edit Box. The parameter is then edited using the numeric keys, the soft-keys, the knob and cursor keys or a combination of these.

Example 1: Press the SQUARE key to select square-wave then press the **Duty** soft-key to select the square-wave duty cycle parameter which will show in the Edit Box. Now use the numeric keys and Soft-keys to change the parameter as described in Numeric Editing.

Example 2: Press the SINE key to select sinewave then press the MOD key to turn on modulation. Press the **Type** soft-key to select the modulation type parameter. Now use the soft-keys to select the required type from **AM**, **FM**, **PM** or **FSK**.

Example 3: Press the ARB key followed by the **Load** soft-key then the **BuiltIn2** soft-key. Now select one of the built in waveforms from the soft-keys. The Edit Box will show the loaded waveform.

In example 3 notice the last two soft keys  and **Done**. These keys often appear when editing and they always perform the same function.



The  key is known as BACK and will move the soft-key labels and Edit Box up one level in the hierarchy; in this example the status will go back to just before the BuiltIn2 soft-key was pressed.

The **Done** key will move back to the top level in the hierarchy; in this example the status will go back to just after the Arb key was pressed.

Numeric Editing

Any numeric parameter may be changed in one of the following ways:

- Enter a new value from the numeric key pad.
- Use the left and right cursor keys to select a digit position then use the knob to increment/decrement the value at that position.

Examples of each method are shown below.

Using the Numeric Key Pad

Pressing a number key will erase the current parameter value in the Edit Box and replace it with the current entry. The Soft-key Labels will also change to a list of units applicable to the parameter being edited. The examples below show frequency units and period (time) units respectively.

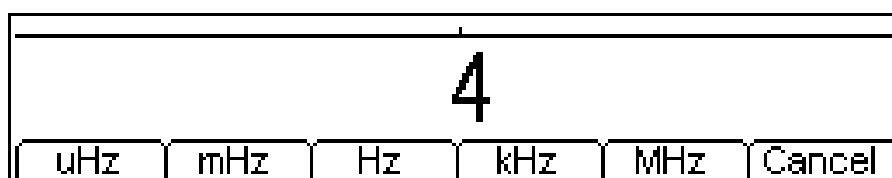

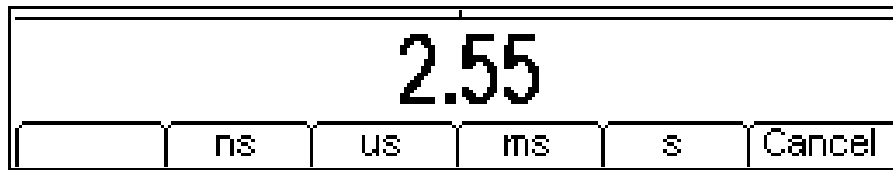

During the numeric data entry a decimal point and, if appropriate, a sign may be entered. The +/- key is used to alternately change the sign between + and -. The left cursor key may be used to erase the last digit entered. The entry may be cancelled by pressing the **Cancel** key

Once the entry is complete it may be terminated by pressing the soft-key below the required units. The value will be checked and accepted as the new value for the relevant parameter.

Using the Knob and Cursor Keys

A numeric parameter will be displayed with an inverse edit cursor over one of the digits. The left and right cursor keys may be used to move the edit cursor to any digit in the value. Values are always shown with enough digits to the right of the decimal point to show the best resolution for the parameter. For example the right-most digit in a frequency value will be μHz . Depending on the actual value one or more digits to the left of the most significant digit displayed may be zero and will not be shown. It is possible to move the edit cursor into these digit positions and the suppressed zeros will be shown as in the example below.

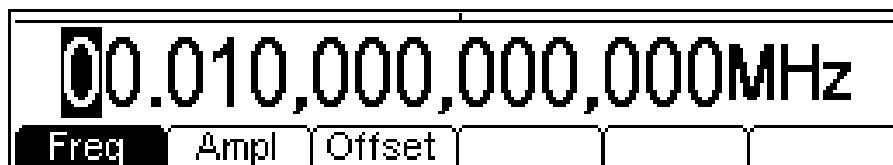

With the edit cursor positioned at the required digit the knob may be rotated left or right to decrement or increment the digit. As the value passes between 9 and 0 the digits to the left will also change. In this way it is possible to set any legal value for the parameter.

Changes made by turning the knob are applied immediately to the parameter as long as the value remains legal.

Display Contrast and Brightness

The LCD contrast may vary a little with changes of ambient temperature or viewing angle but can be optimised for a particular environment by using the contrast and brightness controls. Refer to the Utility Operations section for how to change the contrast and brightness.

Continuous Carrier Waveform Operation

The instrument can generate six types of carrier waveform: sine, square, ramp, pulse, noise and arbitrary. This section deals with the use of the instrument as a simple function generator, i.e. generating sine, square, ramp and arbitrary waveforms continuously with no modulation.

Much of the following description of frequency, amplitude and offset control apply to pulse and noise but these are sufficiently different to be given additional sections of their own.

Setting Generator Parameters

Waveform Selection

Pressing any of the carrier waveform keys, SINE, SQUARE, RAMP or ARB, will immediately switch to that waveform making it available at the MAIN OUT connector if the output is on, indicated by the OUTPUT key glowing green. If the output is not on press the OUTPUT key.

The screen below shows the effect of pressing the RAMP key.

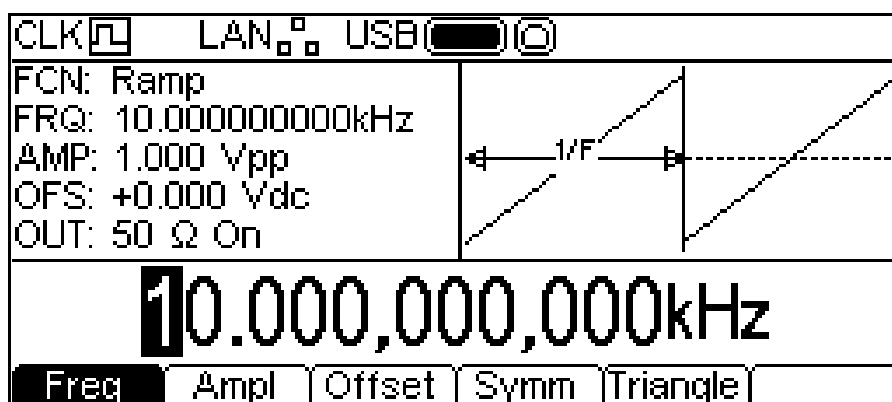

The RAMP key now glows green, the **FCN** field in the Parameters Box shows **Ramp** and the Graph Box has changed to show the ramp waveform.

Frequency

The frequency may be changed in either of the ways detailed in General: Numeric Editing.

Pressing the **Freq** soft-key while it is highlighted will change the label to **Period** and time units will be used to edit the parameter.

Note that the upper frequency limits vary for the different waveform types; refer to the Specifications section for details. Frequency setting for pulse is explained in the relevant section.

Amplitude

Pressing the **Ampl** soft-key shows the amplitude parameter in the Edit Box and the Graph Box changes to show that amplitude is being edited.

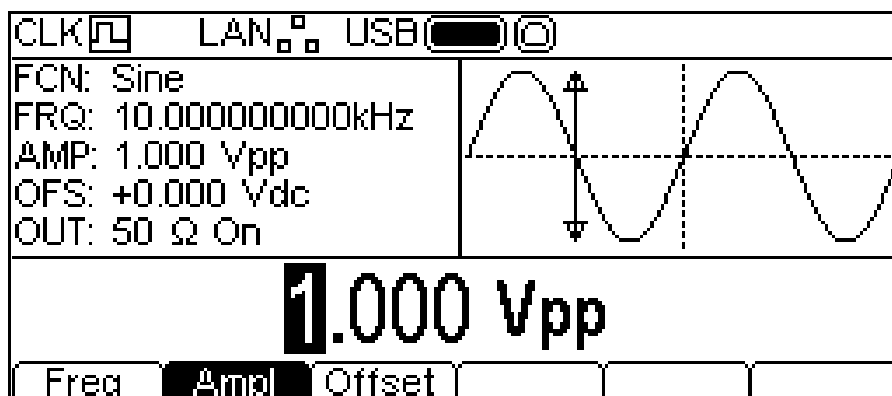

The amplitude may be changed in either of the ways detailed in General: Numeric Editing. The amplitude can be set in terms of peak-to-peak Volts (Vpp), r.m.s. Volts (Vrms) or dBm (referenced to the user specified load, see the section on setting the output load; the default is 50Ω). For Vpp and Vrms the level can be set assuming that the output is either open-circuit or terminated; dBm is not available if the output load is set to HiZ. Note that the actual generator output impedance is always 50Ω; the displayed amplitude values for other load values take this into account.

The +/- key will allow a negative amplitude value to be entered because the units may be selected as dBm where a negative value is meaningful. If the units are not dBm and a negative value is entered a warning will pop up and the value will be accepted as if it had been positive.

DC Offset

Pressing the **Offset** soft-key shows the dc offset parameter in the Edit Box and the Graph Box changes to show that offset is being edited.

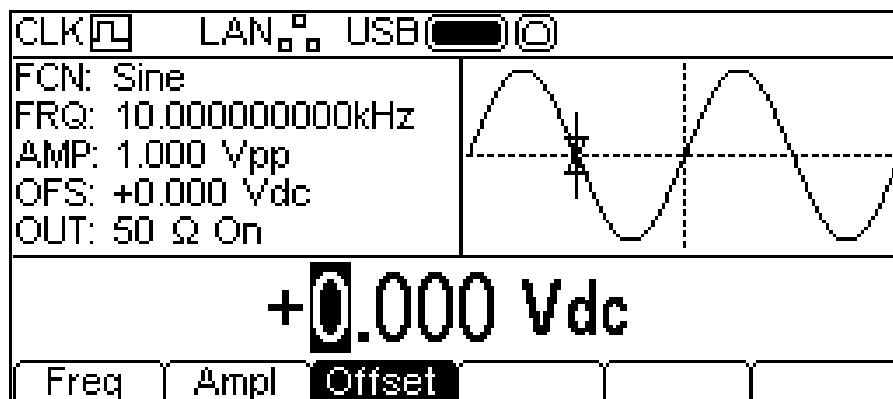

The offset may be changed in either of the ways detailed in General: Numeric Editing. During a new offset entry the +/- key can be used at any time to set a negative offset; alternate presses toggle the sign between + and - .

High Level and Low Level

The instrument allows the amplitude and offset parameters to be entered in terms of high level and low level. Pressing either the **Ampl** or **Offset** soft-key while it is highlighted will switch the mode from amplitude/offset to high/low level. To return to amplitude/offset mode press the highlighted **HiLvl** or **LoLvl** soft-key.

With high/low level mode selected the Edit Box shows the parameter, the Parameters Box shows **HIL** and **LOL** in place of **AMP** and **OFS** and the Graph Box changes to show the parameter which is being edited.

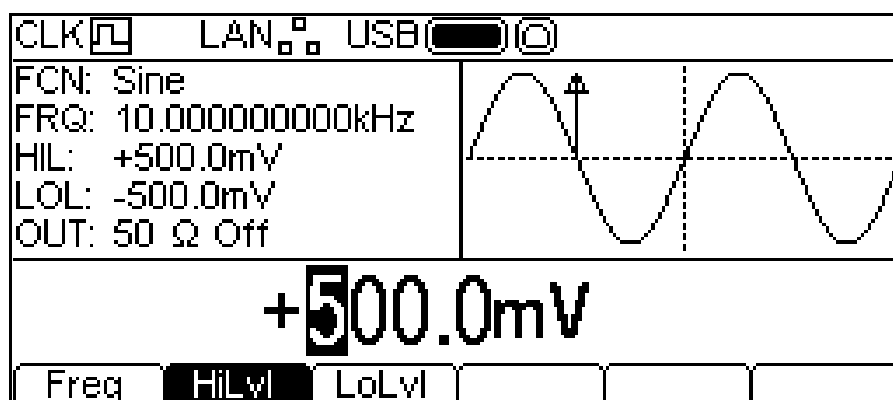

The selected parameter may be changed in either of the ways detailed in General: Numeric Editing. During a new entry the +/- key can be used at any time to set the value negative; alternate presses toggle the sign between + and - .

Special Use of the +/- Key

While editing a parameter which has only positive values the +/- key may be used as a shortcut to invert the output waveform. Alternate presses will set the output between normal and inverted. The inverted state is indicated by **Inv** appearing in the **OUT** field of the Parameters Box and the waveform being shown inverted in the Graph Box. Output inversion may also be done from the Output menu; see the Output menu in the Utilities section.

Square-wave Duty Cycle

With square-wave as the selected waveform pressing the **Duty** soft-key shows the duty cycle parameter in the Edit Box and the Graph Box changes to show that duty cycle is being edited.

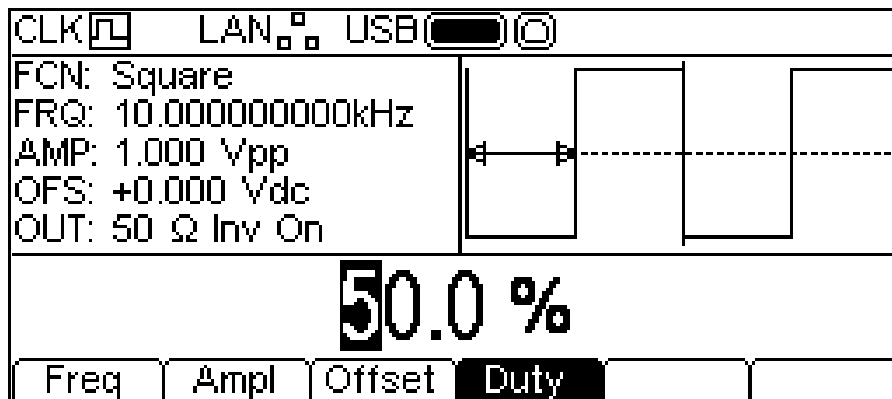

The duty cycle may be changed in either of the ways detailed in General: Numeric Editing.

Ramp Symmetry

With ramp as the selected waveform pressing the **Symm** soft-key shows the symmetry parameter in the Edit Box and the Graph Box changes to show that symmetry is being edited.

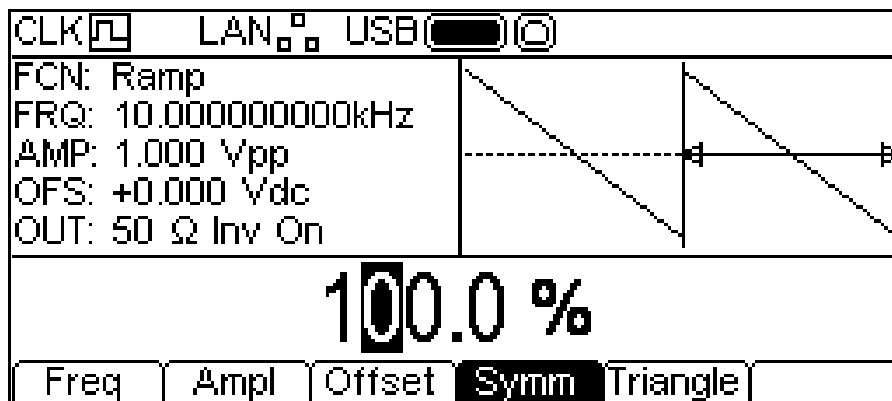

The symmetry may be changed in either of the ways detailed in General: Numeric Editing. The **Triangle** soft-key may be pressed to produce a triangle waveform, i.e. a ramp with 50% symmetry. To return to variable symmetry press the **Symm** soft-key again which will change the symmetry back to the value it had at the time the **Triangle** soft-key was pressed.

Arb Load

The instrument contains a total of eleven arbitrary waveforms, seven fixed and four user defined. There are more waveforms available on the supplied CD.

With arb as the selected waveform, pressing the **Load** soft-key switches to the Arb Load menu. This shows the name of the selected arb in the Edit Box and the Graph Box shows the arb waveform.

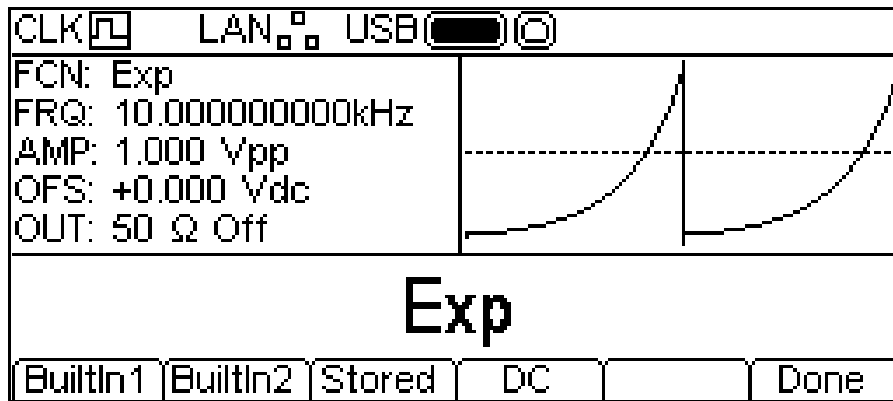

The soft-keys allow access to all the arbitrary waveforms in the instrument. **BuiltIn1** and **BuiltIn2** allow access to seven fixed waveforms which are built into the instrument and may be used like any other arb but cannot be edited. The **stored** soft-key allows access to four waveforms which are user-defined and may be edited or loaded via any interface.

To select an arbitrary waveform press the appropriate soft-key; for example, **BuiltIn1** as shown below.



The required waveform is then selected by pressing the appropriate soft-key. The  and **Done** soft-keys function as described in General: Editing Principles.

Pressing the **DC** soft-key produces a dc only waveform at the MAIN OUT connector. The screen below shows the result of pressing the ARB key with DC as the selected waveform.

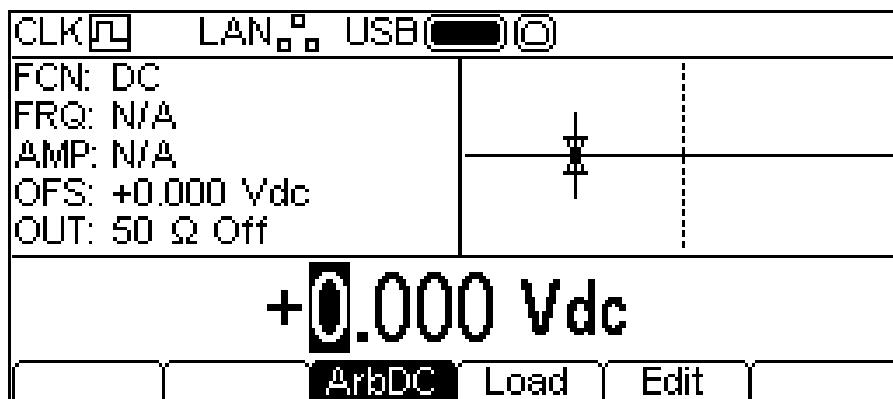

There are no **Freq** or **Amp1** soft-keys and the **Offset** soft-key has changed to **ArbDC**. The Parameters Box shows **DC** in the **FCN** field, the Graph Box shows a dc waveform with dc offset arrows and the Edit Box contains the dc voltage menu. The voltage may be changed in either of the ways detailed in General: Numeric Editing.

Arb Edit

The instrument is capable of performing simple editing of stored arbitrary waveforms. For more complex editing and creation of waveforms see the Waveform Manager Plus Version 4 Windows application supplied on the CD.

With Arb as the selected waveform, pressing the **Edit** soft-key switches to the Arb edit menu. This shows the name of the arb selected for editing in the Edit Box, together with its size in points, and the Graph Box shows the arb waveform.

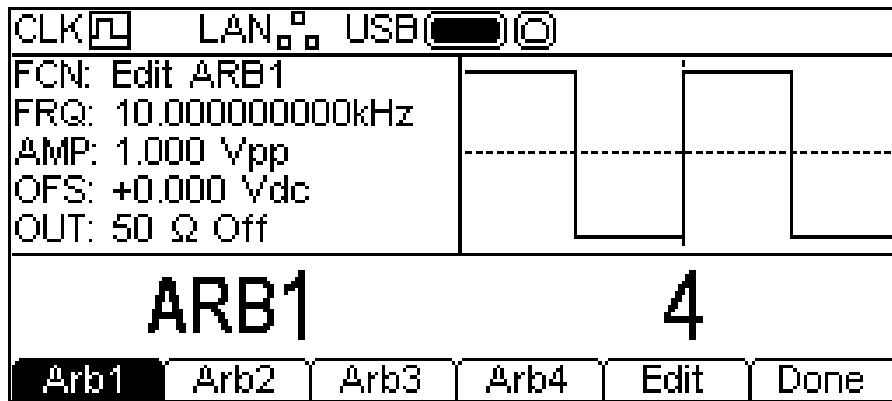

Note that the selected arb is available at the MAIN OUT connector during editing. This is shown by the **FCN** field in the Parameters Box showing **Edit NAME** where **NAME** is the name of the arb being edited. The original waveform will be output on exit from the edit menu.

It is not possible to enter edit mode if modulation, sweep or burst are selected.

The selected waveform is edited by pressing the **Edit** soft-key. For a full description of the editing capabilities see the Editing Arbitrary Waveforms section.

Sync Output

SYNC OUT is a multifunction LVTTTL level output that can be automatically or manually set to be any of the following:

- **Carrier Sync** : A square wave at the same frequency and duty as the carrier waveform. Available for all waveforms except Noise.
- **Modulation Sync**: A square-wave at the same frequency as the internal modulation waveform with a duty of 50%. Not available for external modulation.
- **Sweep Sync**: Outputs the sweep trigger and sweep marker signals.
- **Burst Sync** : A square wave coincident with a burst output.
- **Trigger** : A buffered version of the Trigger signal .

The selection of the signals themselves is discussed in the **UTILITY-Sync** menu. By default the automatic selection is enabled which will choose the most relevant output for the instrument set-up. However, it is possible to override the automatic setting. See the **UTILITY-Sync** menu for more information.

Information, Warning and Error Messages

Three classes of message are displayed on the screen in a Pop-up Box.

INFORMATION messages are shown to inform the user of actions that are being taken, for example:

Please wait... the current settings are being saved

WARNING messages are shown when the entered setting causes some change which the user might not necessarily expect. For example:

With square-wave selected at 1MHz and a Duty cycle of 25%, select sinewave and change the frequency to 25 MHz. Then select square-wave again and the message **Duty cycle has been changed, Fixed to 50% for current frequency** will pop up.

ERROR messages are shown when an illegal setting is attempted, most generally a number outside the range of values permitted. In this case the entry is rejected and the parameter setting is left unchanged.

Examples are:

1. Entering a frequency of 1MHz for a triangle waveform. The error message **"Frequency invalid Upper limit 500kHz"** is shown.
2. Entering a sinewave amplitude of 25Vpp. The error message **"Amplitude invalid Upper limit 10.000 Vpp"** is shown
3. Entering a DC offset of 20V on a sinewave with an amplitude of 1.000 Vpp. The error message **"Offset invalid Upper limit 4.500 Vdc"** is shown.

The messages are shown on the display for approximately four seconds; however, pressing any key will immediately remove the Pop-up Box and execute the function of the key which is pressed. The last two messages can be viewed again by pressing the **Help** key and selecting the first or second entries from the Help menu, see Help Operations section.

Each message has a number and the full list appears in Appendix 1.

Each warning and error message is accompanied by a beep. The beep may be enabled or disabled in the **UTILITY – System** menu.

Pulse Generator

General

The pulse generator can produce a wide range of pulses with adjustable period, width, delay and edge speed. It may also be set in Gated or Burst mode, or modulated using PWM; for more information see the sections on Modulation and Burst.

Pressing the PULSE carrier waveform key will switch to the pulse waveform. The screen below shows the effect of pressing the PULSE key.

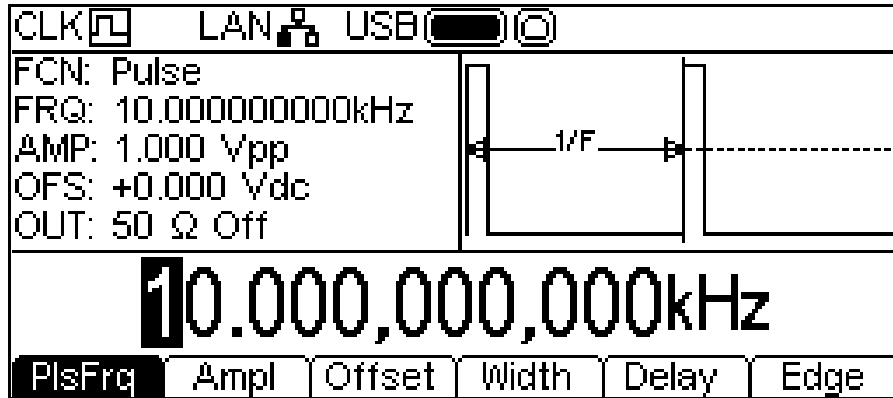

The **PlsFrq** soft-key allows setting of the pulse frequency. Pressing the key while it is highlighted will change it to **PlsPrd** and the pulse period may be entered. The pulse frequency may be changed in either of the ways detailed in General: Numeric Editing. The pulse generator uses its own value for pulse frequency/pulse period. Changing it will not affect the frequency/period value of the other carrier waveforms.

Amplitude and dc offset are adjusted in the same way as for sinewaves and they may also be set in terms of high level and low level. These parameters may be changed in either of the ways detailed in General: Numeric Editing.

Pulse Width

Pressing the **width** soft-key shows the Width parameter in the Edit Box and the Graph Box changes to show that width is being edited.

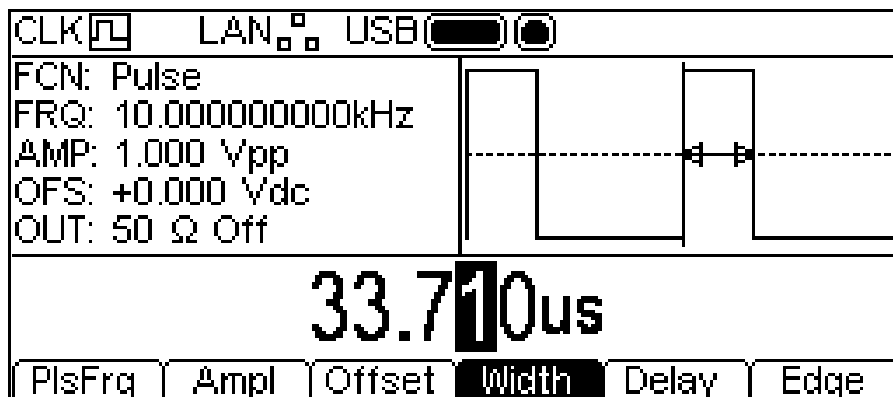

The Width may be changed in either of the ways detailed in General: Numeric Editing. Pressing the **width** soft-key while it is highlighted will change it to **Duty** and the duty cycle may be changed in terms of the percentage of the pulse period.

Pulse Delay

Pressing the **Delay** soft-key shows the delay parameter in the Edit Box and the Graph Box changes to show that delay is being edited.

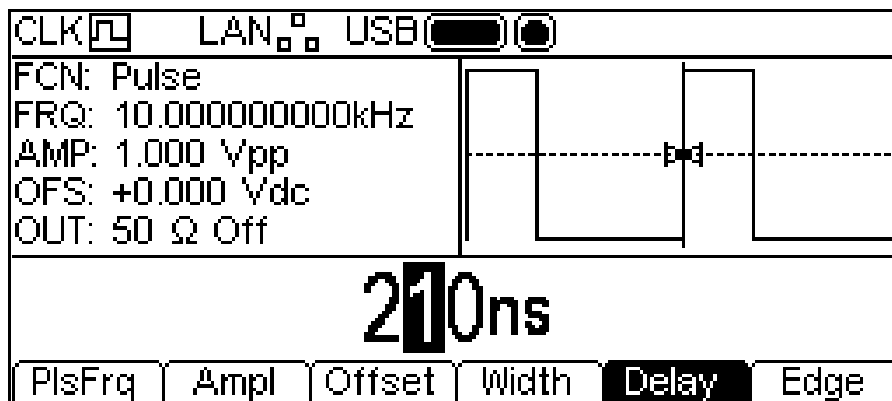

The delay may be changed in either of the ways detailed in General: Numeric Editing.

Changing the delay causes the start of the pulse to be delayed with respect to the **carrier** sync pulse available at the SYNC OUT connector. The delay also adds a delay between the trigger signal and the pulse output during burst and gate modes. See the Burst section for more details of Burst and Gate modes.

Rise Time and Fall Time

Pressing the **Edge** soft-key shows the edge parameter in the Edit Box and the Graph Box changes to show that edge is being edited. The soft-keys also change to present more options for editing the edge times of the pulse.

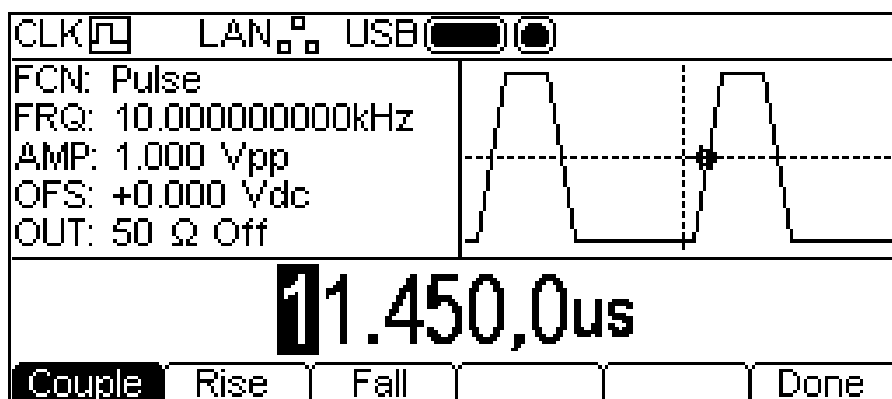

The selected edge time may be changed in either of the ways detailed in General: Numeric Editing.

There are three ways to adjust the edge times:

1. **Couple:** The edges are changed together.
2. **Rise:** Only the Rising edge is changed.
3. **Fall:** Only the falling edge is changed.

If **Rise** or **Fall** are selected the soft keys will change as shown below.



There is now a **Range** soft-key. If this is pressed the display changes to:



When using the independent options both edge times must use the same range. Choose the range by pressing the appropriate soft-key. When using the coupled option the range will change automatically as the edge times are edited. Press the **Execute** soft-key to set the selected range and return to the previous menu or press the **↕** soft key to return without changing the range.

Noise Generator

The instrument contains a wide-band Gaussian white noise generator which may be used in the following ways:

- As the main output from the carrier wave generator
- As a modulating waveform
- Added as a percentage to the current output waveform

These options are described in the following sections.

Carrier Wave Noise

Pressing the NOISE key will switch to the noise function and show the screen below.

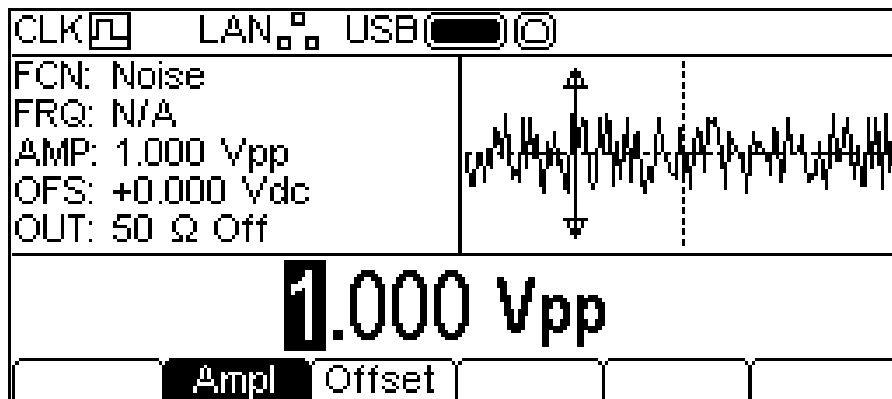

There is no **Freq** soft-key because the noise frequency cannot be edited. The amplitude or dc offset may be changed in either of the ways detailed in General: Numeric Editing. It is also possible to edit these parameters in terms of high level and low level.

Noise Modulation

Noise may be used as a modulation shape in the same way as sine or ramp etc. However, noise cannot be used as a carrier wave for modulation. See the Modulation section for more information.

Added Noise

Noise may be added to any output waveform except square, pulse and noise. However, it is possible to add noise to the arbitrary square-wave found at **ARB-Load-BuiltIn2-Square**. See the Continuous Carrier Waveform Operation: Arb Load section for more information on built in arbs.

To add noise to the output waveform press the UTILITY key, then the **Output** soft-key, then the **NseAd** soft-key. See the display below.

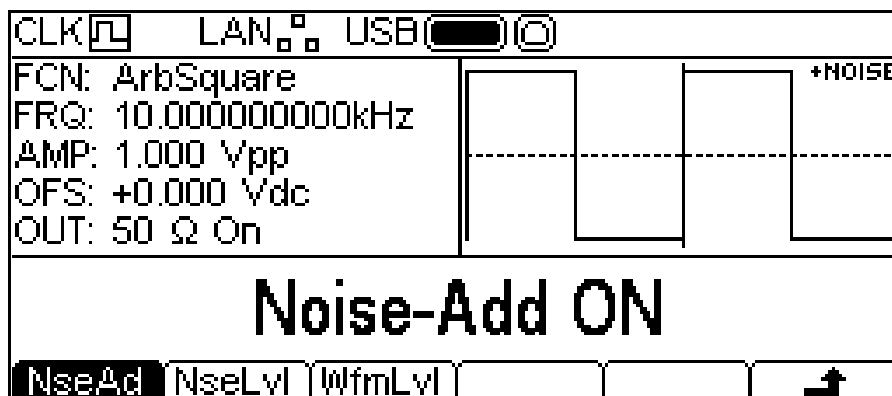

Pressing the **NseAd** soft-key will alternate between **Noise-Add ON** and **Noise-Add OFF**. With noise added the Graph Box shows **+NOISE** in the top right corner and two extra soft-key labels appear, **NseLvl** and **WfmLvl**.

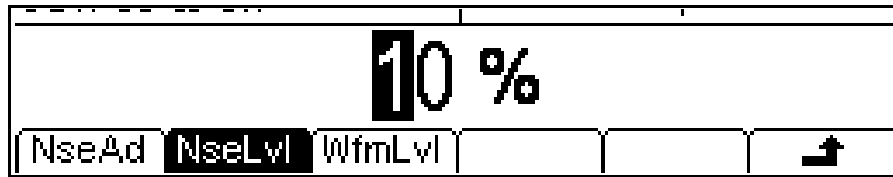

Pressing the **NseLvl** key allows the noise percentage to be set. Pressing the **WfmLvl** key allows the Waveform percentage to be set. These parameters may be changed in either of the ways detailed in General: Numeric Editing. Using the two parameters the ratio may be set anywhere in the range 50% waveform and 50% noise to 99% waveform and 1% noise.

Press the UTILITY key to exit from the Utility menus.

General

The instrument can apply five types of modulation: AM (Amplitude Modulation), FM (Frequency Modulation), PM (Phase Modulation), PWM (Pulse Width Modulation) and FSK (Frequency Shift Keying). It is not possible to apply all modulations to all carrier types or to simultaneously apply more than one modulation to any carrier type. For example, PWM cannot be applied to sine, and noise cannot be modulated at all. However, sine and noise may be used as the modulation shape for any type of modulation except FSK. See the following sections or the Specification section for information on carrier waveforms and modulation types and shapes which are supported.

Pressing the MOD key will apply the currently selected modulation to the currently selected carrier waveform and the MOD key will glow yellow. The screen below shows the effect of pressing the MOD key when Sine is the selected waveform and the selected modulation type is AM.

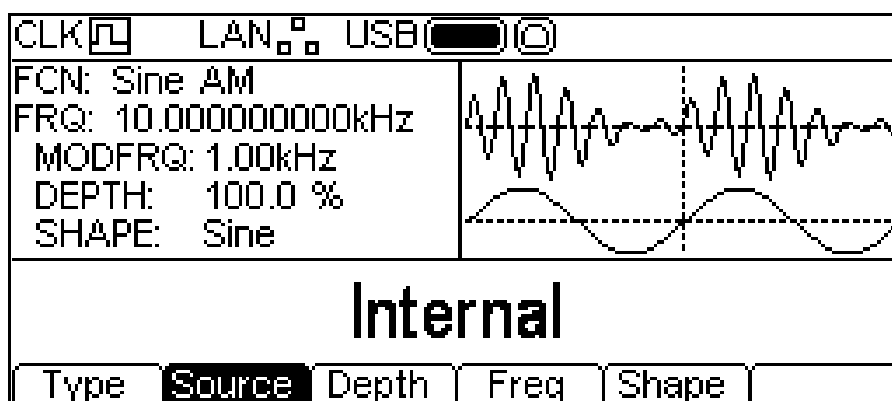

The Parameters Box now shows the current modulation parameters of **MODFRQ**, **DEPTH** and **SHAPE** and **AM** is shown in the **FCN** field. The Graph Box shows the modulating waveform below a representation of the modulated carrier waveform. The Edit Box contains the selected parameter, in this case modulation **Source**.

To change the carrier waveform parameters press the highlighted carrier waveform key which will return the display to the carrier menu as shown below.

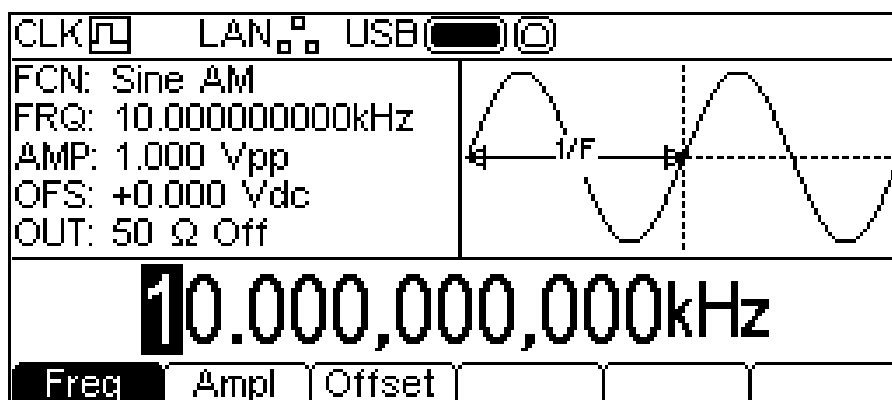

Notice that **AM** still shows in the **FCN** field of the Parameters Box and the MOD key still glows yellow indicating that modulation is still active. To return to the modulation menu to edit the modulation parameters press the MOD key again. To turn off modulation press the MOD key while the modulation menu is displayed.

The following sections discuss the parameter choices for each type of modulation. Only one modulation type may be applied to any one time.

AM

To select AM press the MOD key to turn on modulation and then press the **Type** soft-key to show the display below.

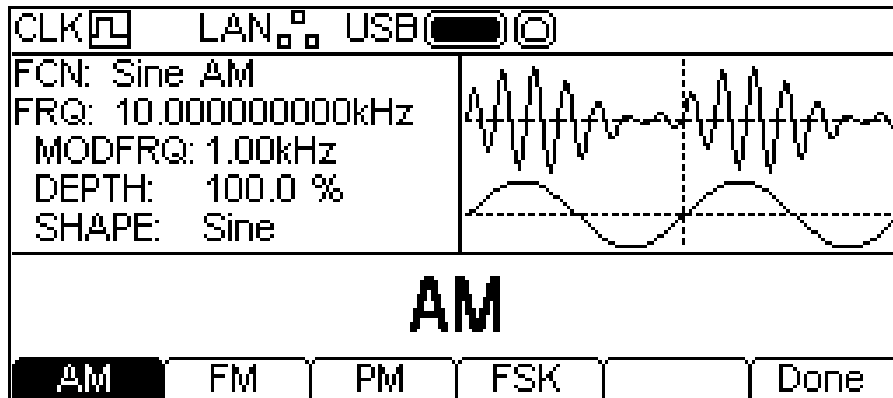

The soft-keys present all of the modulation types which may be applied to the selected carrier waveform. If **AM** is not already selected press the **AM** soft-key followed by the **Done** key to return to the top level modulation menu.

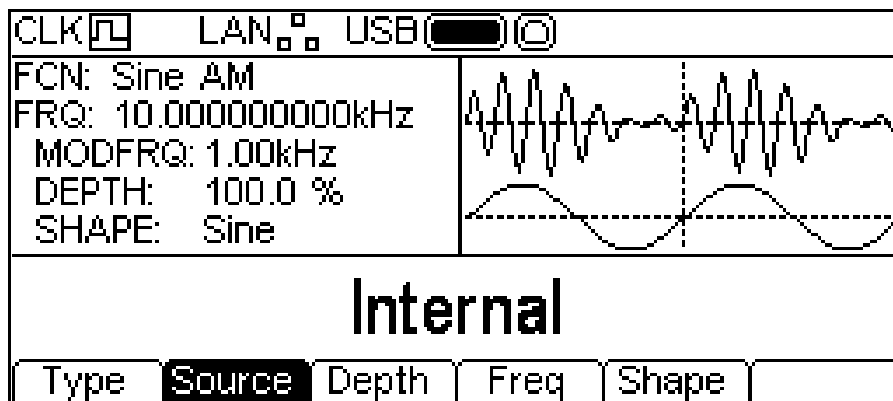

To select the modulation source press the **Source** soft-key. The options are **Internal** or **External**. Internal will use the waveform specified in the shape parameter and the Graph Box will show that shape as the modulating waveform. External will use the signal present at the MOD IN connector and the **Freq** and **Shape** soft-keys will disappear. The Graph Box will always show a sinewave as the modulating waveform if the source is set to External.

To set the modulation depth press the **Depth** soft-key. The Depth parameter will appear in the Edit Box and the modulating waveform in the Graph Box will show that depth is being edited.

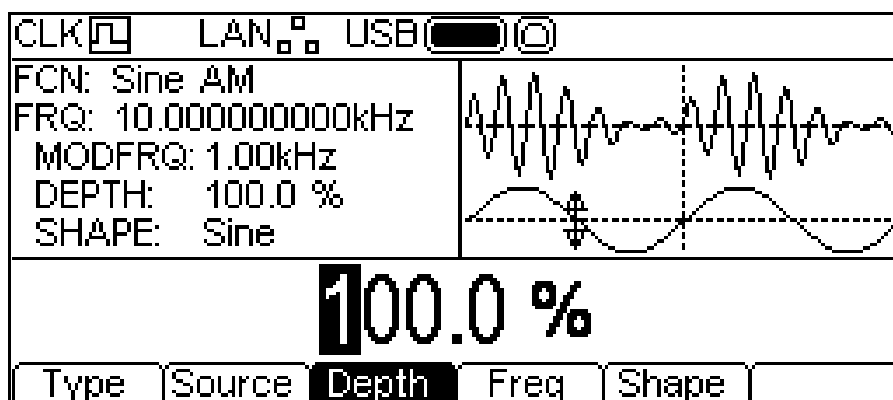

The depth may be changed in either of the ways detailed in General: Numeric Editing.

To set the modulation frequency press the **Freq** soft-key. The frequency parameter will appear in the Edit Box and the modulating waveform in the Graph Box will show that frequency is being edited.

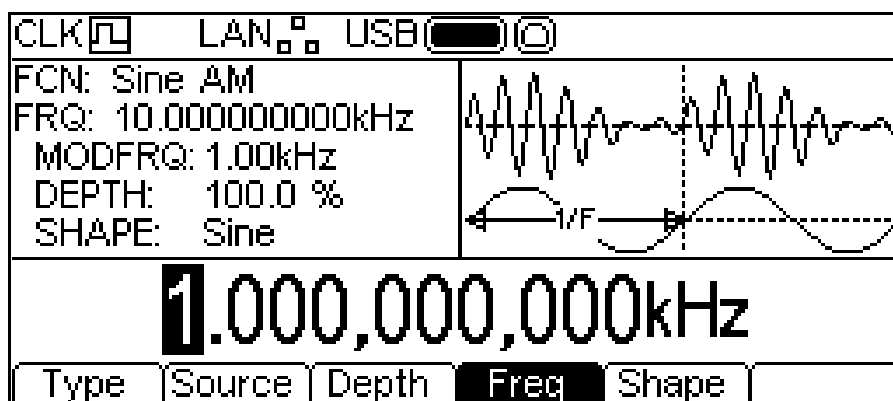

The frequency may be changed in either of the ways detailed in General: Numeric Editing.

To set the modulation shape press the **shape** soft-key. The currently selected shape will appear in the Edit Box and the soft-keys will change to a list of shapes available.

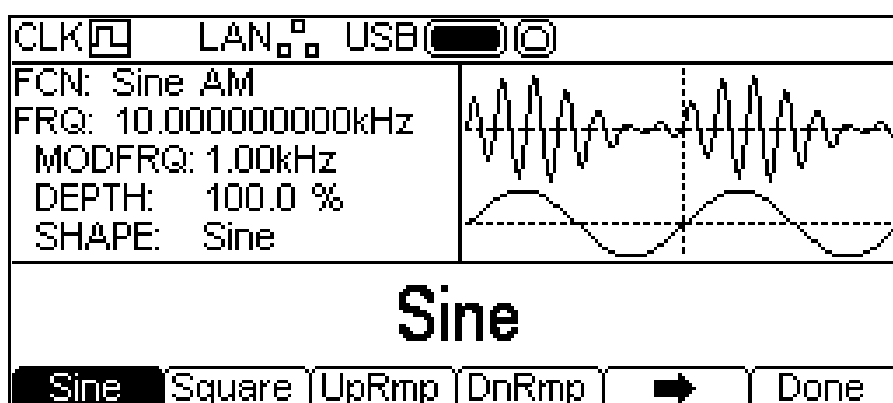

The **➡** soft-key indicates that there are too many options to show all at once so press this key to show more. In this case there are three more lists of shapes which will show with successive presses of the **➡** soft-key.



One more press of the **➡** soft-key will show the first list again. Select the modulation shape required by pressing the appropriate key then press the **Done** soft-key to return to the top level modulation menu.

All the parameters for AM are now set.

FM

To select FM press the MOD key to turn on modulation and then press the **Type** soft key to show the display below.

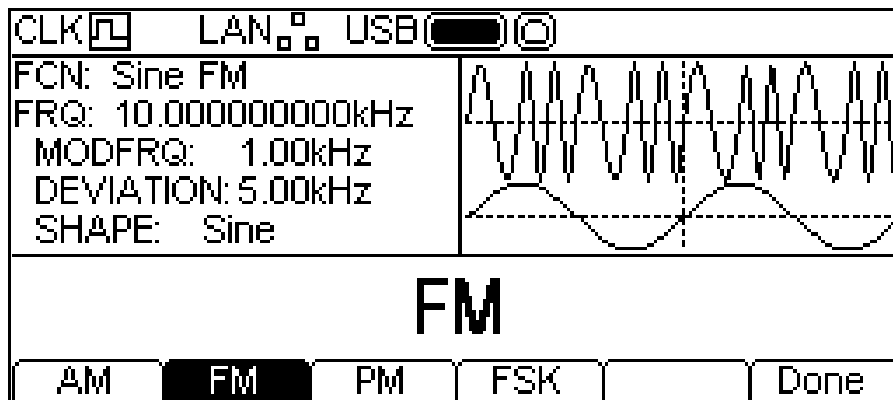

The soft-keys present all of the modulation types which may be applied to the selected carrier waveform. If **FM** is not already selected press the **FM** soft-key followed by the **Done** key to return to the top level modulation menu.

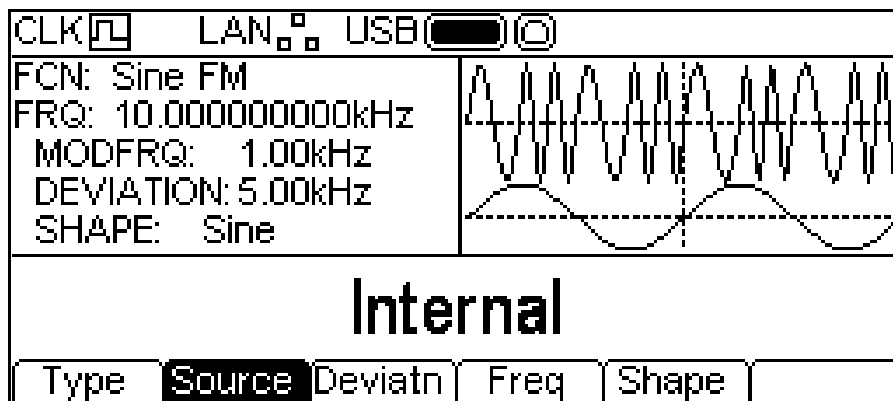

To select the modulation source press the **Source** soft-key. The options are **Internal** or **External**. Internal will use the waveform specified in the shape parameter and the Graph Box will show that shape as the modulating waveform. External will use the signal present at the MOD IN connector and the **Freq** and **Shape** soft-keys will disappear. The Graph Box will always show a sinewave as the modulating waveform if the source is set to External.

To set the frequency deviation press the **Deviatn** soft-key. The deviation parameter will appear in the Edit Box and the modulating waveform in the Graph Box will show that deviation is being edited.

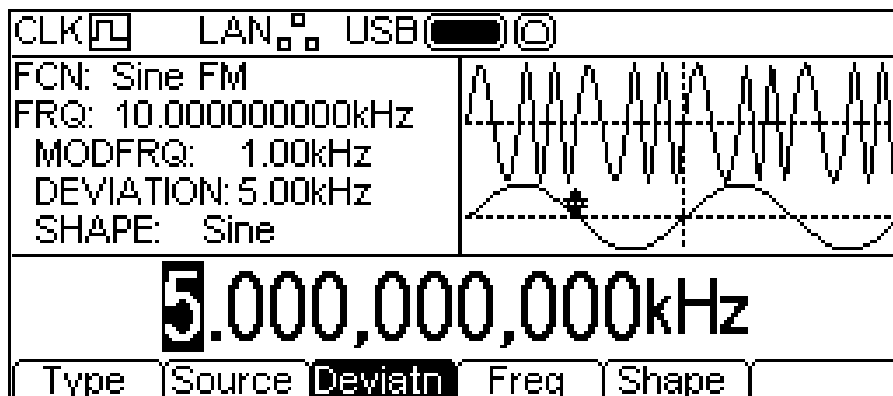

The deviation may be changed in either of the ways detailed in General: Numeric Editing.

To set the modulation frequency press the **Freq** soft-key. The frequency parameter will appear in the Edit Box and the modulating waveform in the Graph Box will show that frequency is being edited.

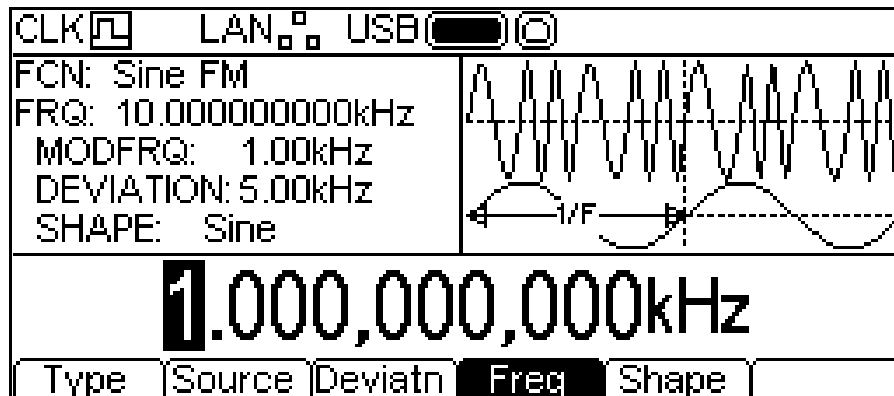

The frequency may be changed in either of the ways detailed in General: Numeric Editing.

To set the modulation shape press the **shape** soft-key. The currently selected shape will appear in the Edit Box and the soft-keys will change to a list of shapes available.

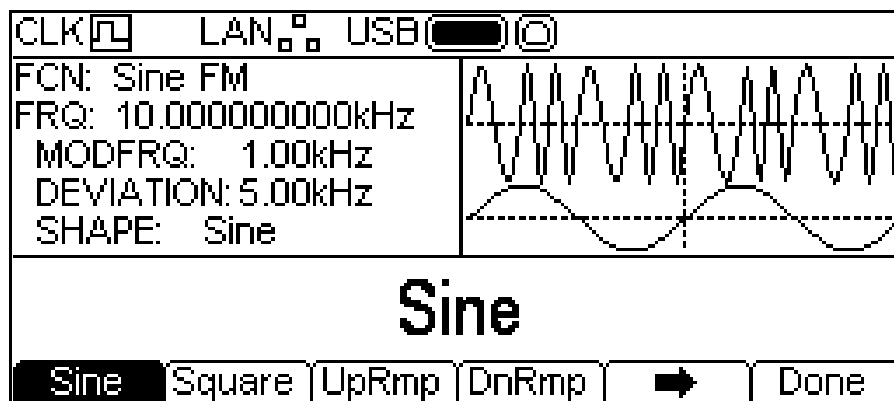

The **➡** soft-key indicates that there are too many options to show all at once so press this key to show more. In this case there are three more lists of shapes which will show with successive presses of the **➡** soft-key.



One more press of the **→** soft-key will show the first list again. Select the modulation shape required by pressing the appropriate key then press the **Done** soft-key to return to the top level modulation menu.

All the parameters for FM are now set.

PM

To select PM press the MOD key to turn on modulation and then press the **Type** soft key to show the display below.

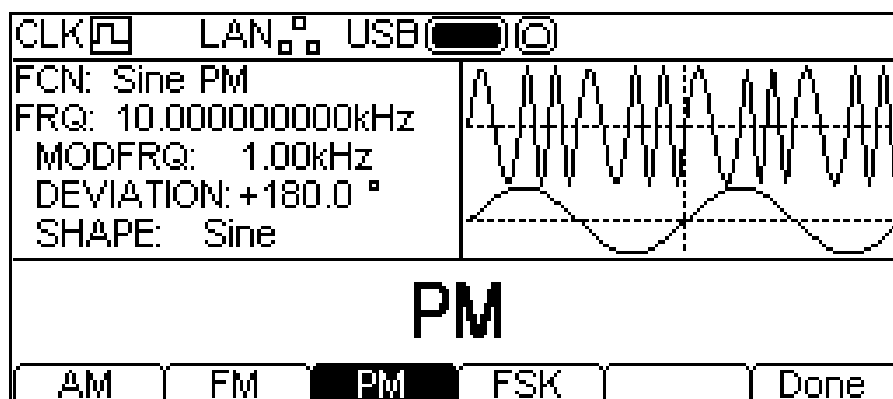

The soft-keys present all of the modulation types which may be applied to the selected carrier waveform. If **PM** is not already selected press the **PM** soft-key followed by the **Done** key to return to the top level modulation menu.

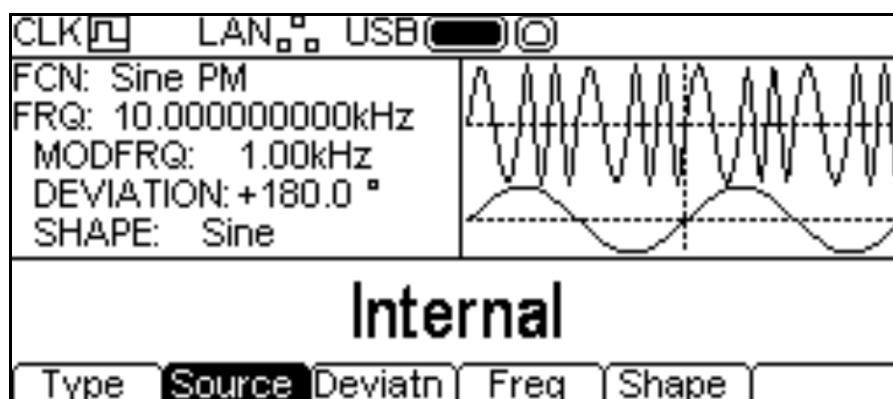

To select the modulation source press the **Source** soft-key. The options are **Internal** or **External**. Internal will use the waveform specified in the shape parameter and the Graph Box will show that shape as the modulating waveform. External will use the signal present at the MOD IN connector and the **Freq** and **Shape** soft-keys will disappear. The Graph Box will always show a sinewave as the modulating waveform if the source is set to External.

To set the phase deviation press the **Deviatn** soft-key. The deviation parameter will appear in the Edit Box and the modulating waveform in the Graph Box will show that deviation is being edited.

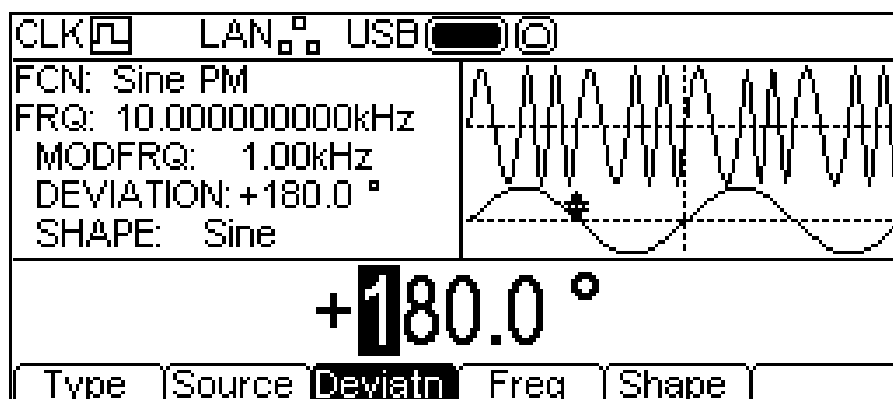

The deviation may be changed in either of the ways detailed in General: Numeric Editing.

To set the modulation frequency press the **Freq** soft-key. The frequency parameter will appear in the Edit Box and the modulating waveform in the Graph Box will show that frequency is being edited.

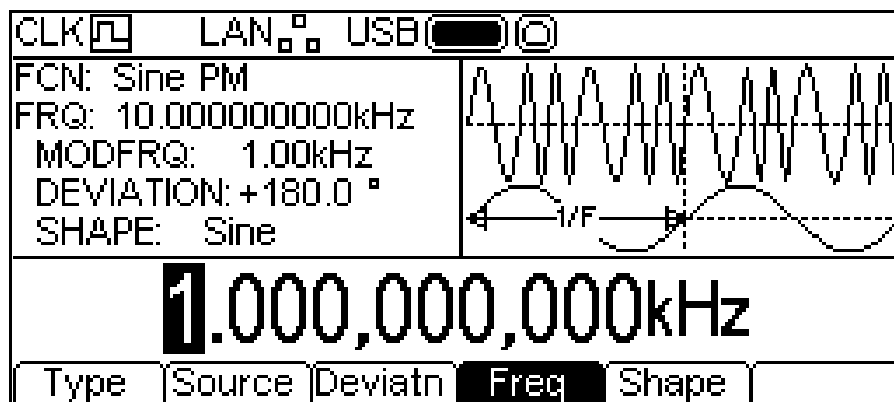

The frequency may be changed in either of the ways detailed in General: Numeric Editing.

To set the modulation shape press the **Shape** soft-key. The currently selected shape will appear in the Edit Box and the soft-keys will change to a list of shapes available.

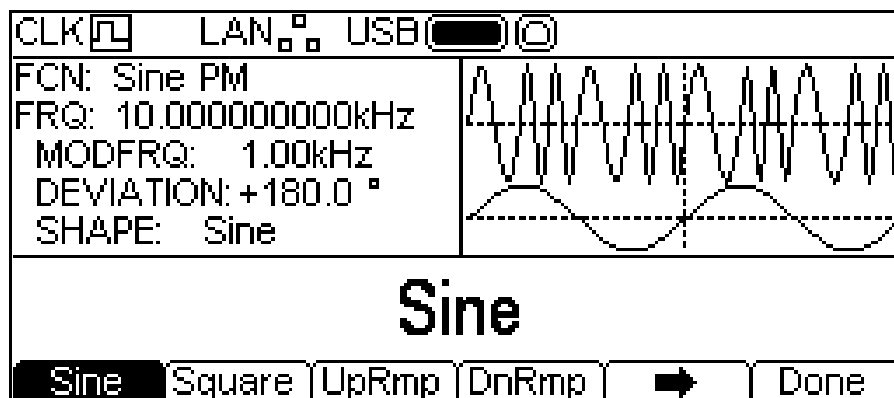

The ➡ soft-key indicates that there are too many options to show all at once so press this key to show more. In this case there are three more lists of shapes which will show with successive presses of the ➡ soft-key.



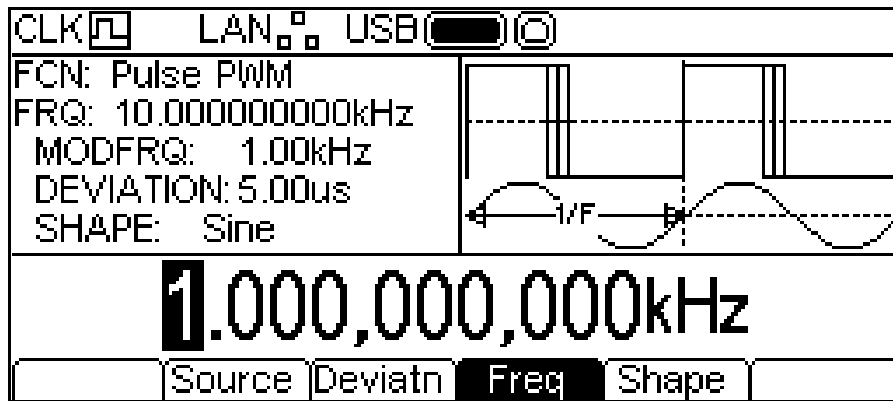

The frequency may be changed in either of the ways detailed in General: Numeric Editing. To set the modulation shape press the **shape** soft-key. The currently selected shape will appear in the Edit Box and the soft-keys will change to a list of shapes available.

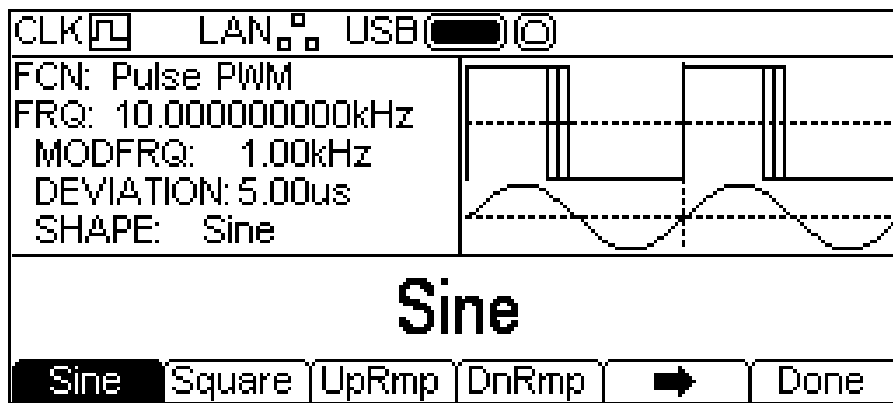

The **➡** soft-key indicates that there are too many options to show all at once so press this key to show more. In this case there are three more lists of shapes which will show with successive presses of the **➡** soft-key.



One more press of the **➡** soft-key will show the first list again. Select the modulation shape required by pressing the appropriate key then press the **Done** soft-key to return to the top level modulation menu.

All the parameters for PWM are now set.

FSK

To select FSK press the MOD key to turn on modulation and then press the **Type** soft key to show the display below.

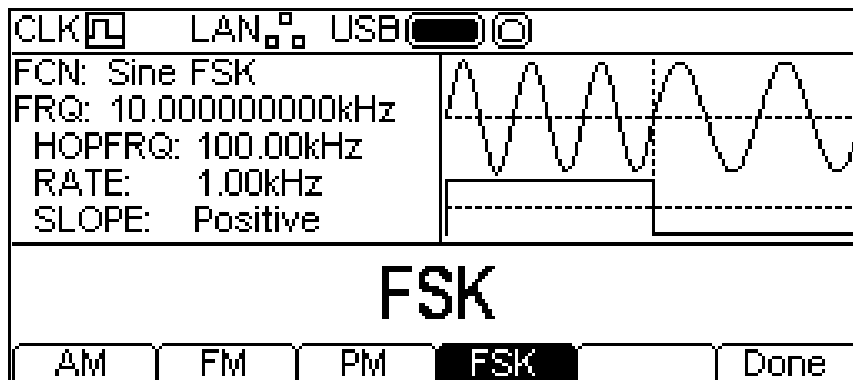

The soft-keys present all of the modulation types which may be applied to the selected carrier waveform. If **FSK** is not already selected press the **FSK** soft-key followed by the **Done** key to return to the top level modulation menu.

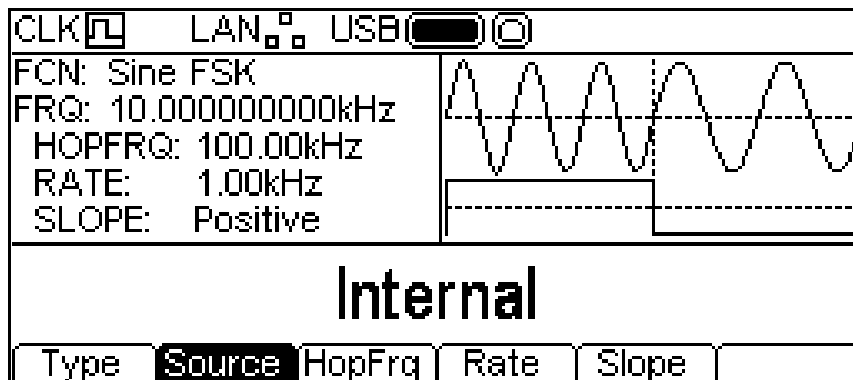

To select the modulation source press the **Source** soft-key. The options are **Internal** or **External**. Internal will use an internally generated trigger signal, external will use the signal present at the TRIG IN connector and the **Rate** soft-key will disappear. The Graph Box will show a switching carrier and a square-wave as the modulating waveform irrespective of the source of the switching signal.

FSK will generate the carrier frequency while the switching signal is false and the hop frequency while the switching signal is true. To set the hop frequency press the **HopFrq** soft-key. The hop frequency parameter will appear in the Edit Box and the modulating waveform in the Graph Box will show that hop frequency is being edited.

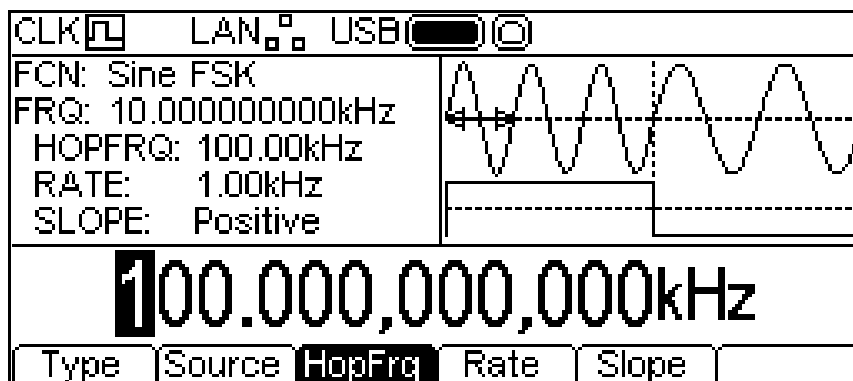

The hop frequency may be changed in either of the ways detailed in General: Numeric Editing.

To set the switching rate press the **Rate** soft-key. The rate parameter will appear in the Edit Box and the modulating waveform in the Graph Box will show that the switching rate is being edited.

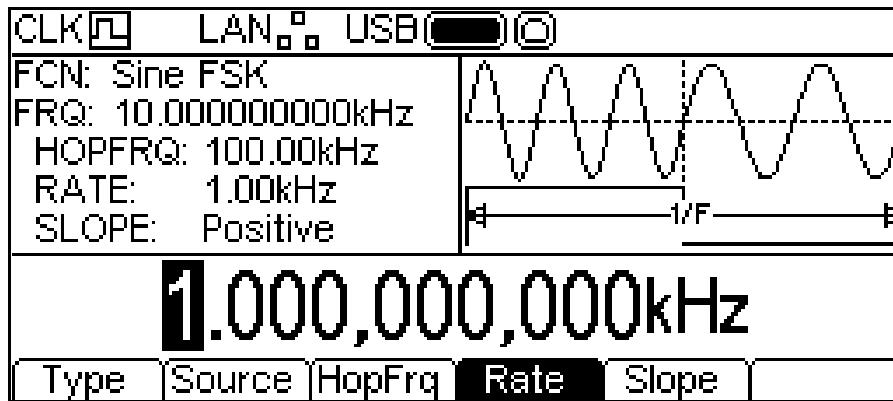

The rate may be changed in either of the ways detailed in General: Numeric Editing.

To set which level of the switching signal will output the hop frequency press the **Slope** soft-key. The currently selected slope will appear in the Edit Box.

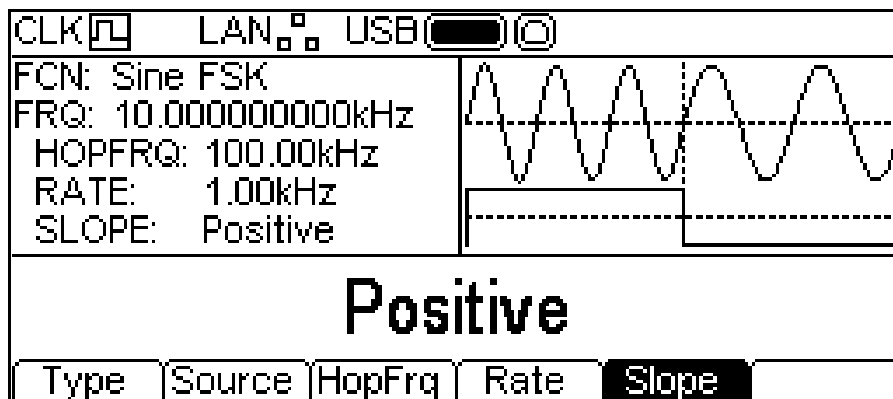

The options are **Positive** or **Negative**. Setting positive will cause FSK to generate the hop frequency while the switching signal is high and the carrier frequency while the switching signal is low. Setting negative will cause FSK to generate the hop frequency while the switching signal is low and the carrier frequency while the switching signal is high.

All the parameters for FSK are now set.

General

All waveforms can be swept with the exception of Pulse and Noise. The sweep function allows the carrier frequency to be swept using small frequency steps from the start frequency to the stop frequency. There are over 16000 steps and this remains constant for all sweep times and frequency spans.

Pressing the SWEEP key will apply the currently selected sweep parameters to the currently selected carrier waveform and the SWEEP key will glow yellow. The screen below shows the effect of pressing the SWEEP key when sine is the selected waveform.

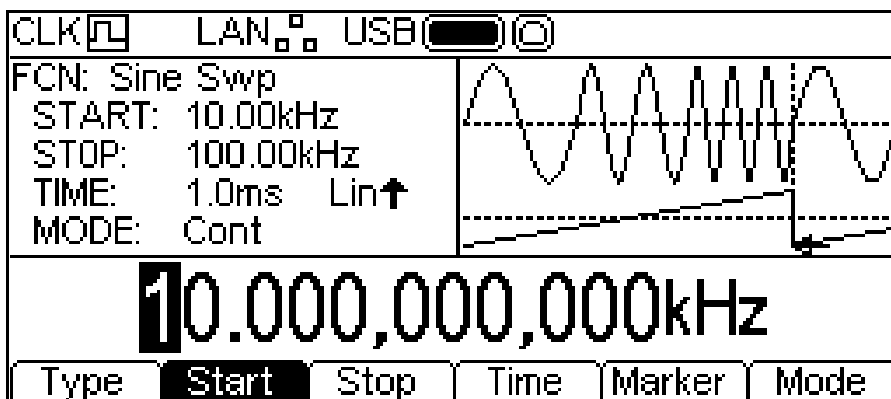

The Parameters Box now shows the current sweep parameters of **START** (frequency), **STOP** (frequency), **TIME** and **MODE** and **Swp** is shown in the **FCN** field. The **TIME** field also shows the sweep type. The Graph Box shows the sweep waveform type below a representation of the swept carrier waveform. The Edit Box contains the selected parameter, in this case start frequency.

To change the carrier waveform parameters press the highlighted carrier waveform key which will return the display to the carrier menu as shown below.

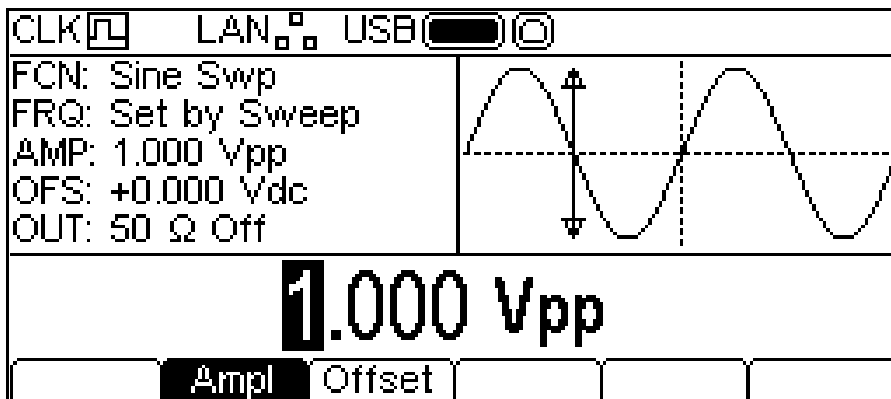

Notice that **Swp** still shows in the **FCN** field of the Parameters Box and the SWEEP key still glows yellow indicating that sweep is still active. To return to the Sweep menu to edit the sweep parameters press the SWEEP key again. To turn off sweep press the SWEEP key while the Sweep menu is displayed.

Notice also that there is no **Freq** soft-key and the FRQ field in the parameters box shows **Set by Sweep**. It is still possible to edit amplitude and dc offset.

The following sections discuss the parameter choices for sweep.

Sweep Type

To set the sweep type press the **Type** soft-key. The currently selected type will appear in the Edit Box and soft-keys will change to a list of sweep types available.

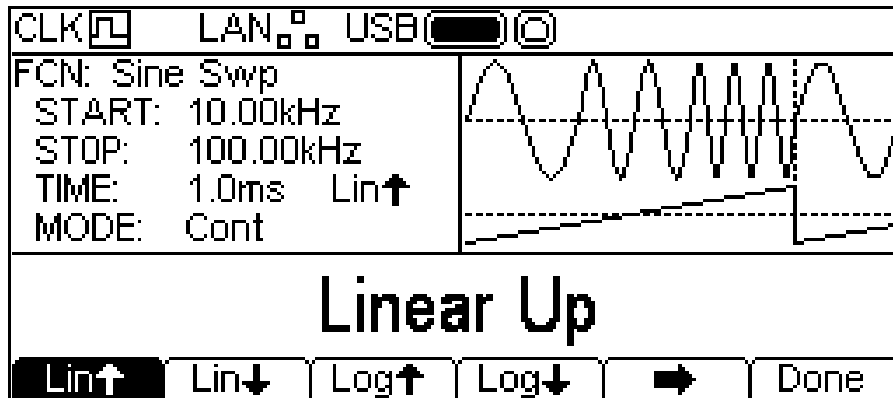

The **→** soft-key indicates that there are too many options to show all at once so press this key to show more. In this case there is one more list of types.



One more press of the **→** soft-key will show the first list again. Select the sweep type required by pressing the appropriate key then press the **Done** soft-key to return to the top level Sweep menu.

The arrows indicate up or down or up/down sweeps. With any of the **Lin** types selected the sweep changes the frequency at a linear rate; with **log** types selected the sweep spends an equal time in each frequency decade.

The up arrows indicate a sweep from start frequency to stop frequency. The down arrows indicate a sweep from stop frequency to start frequency.

Start and Stop Frequency

To set the start or stop frequency press the **Start** or **Stop** soft-keys. The frequency parameter will appear in the Edit Box and the sweep waveform type in the Graph Box will show that start or stop frequency is being edited.

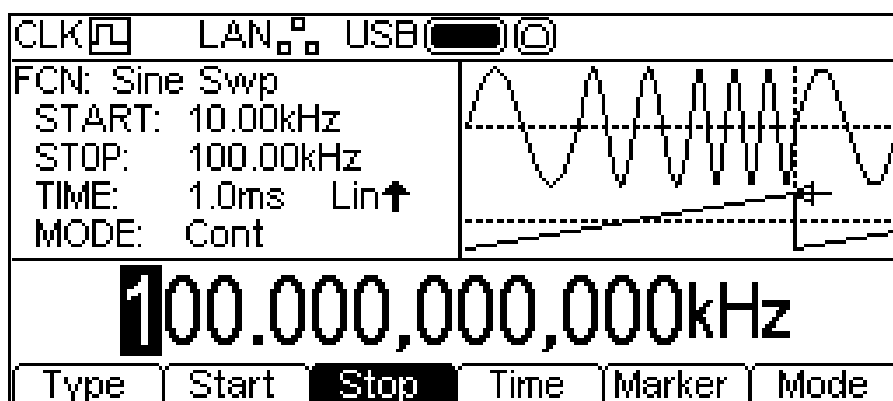

The frequencies may be changed in either of the ways detailed in General: Numeric Editing.

The start frequency must be lower than the stop frequency, if this is not the case an error will be generated.

Centre and Span

The instrument also allows the start and stop frequency parameters to be entered in terms of centre and span. Pressing either the **Start** or **Stop** soft-key while it is highlighted will switch the mode from start/stop to centre/span. To return to start/stop mode press the highlighted **Centre** or **Span** soft-key.

With centre/span mode selected the Edit Box shows the parameter, the Parameters Box shows **CENTRE** and **SPAN** in place of **START** and **STOP** and the Graph Box changes to show the parameter which is being edited.

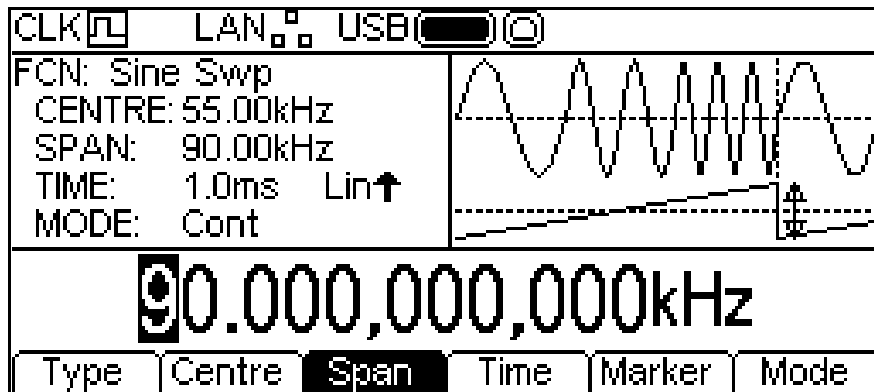

The selected parameter may be changed in either of the ways detailed in General: Numeric Editing.

Sweep Time

To set the sweep time press the **Time** soft-key. The time parameter will appear in the Edit Box and the Graph Box will show that sweep time is being edited.

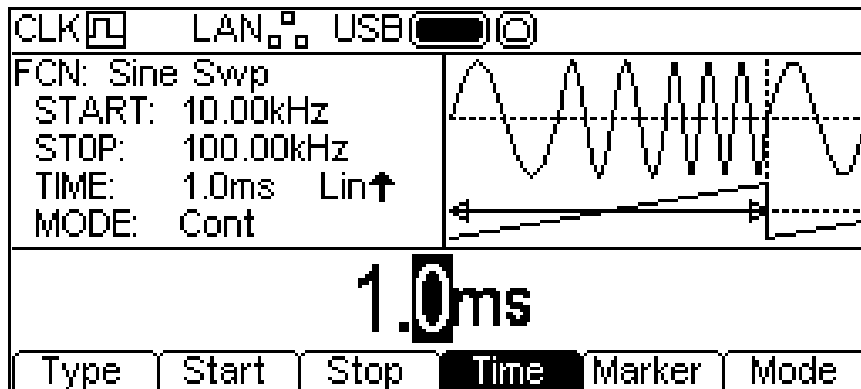

The sweep time may be changed in either of the ways detailed in General: Numeric Editing.

Frequency Marker

The sweep frequency marker may be set to any frequency within the sweep range or it may be turned off. The sweep marker and the sweep sync form a composite signal which appears at the SYNC OUT connector as **Sweep Sync**. This signal goes high at the start of sweep and then goes low as the sweep goes through the marker frequency. If the marker is off the **Sweep Sync** signal goes low at the mid point of the sweep.

To set the frequency marker press the **Marker** soft-key. The marker parameter will appear in the Edit Box and the Graph Box will show that sweep marker is being edited.

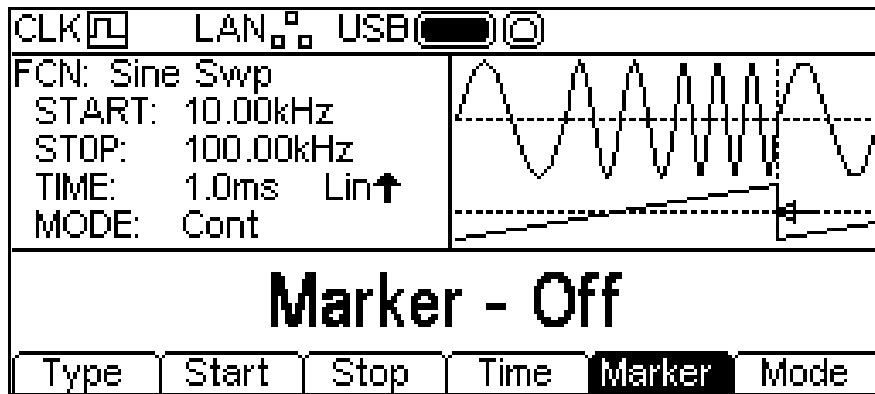

If the marker is disabled the Edit Box will show **Marker - Off**. To enable the marker press the **Marker** soft-key again.

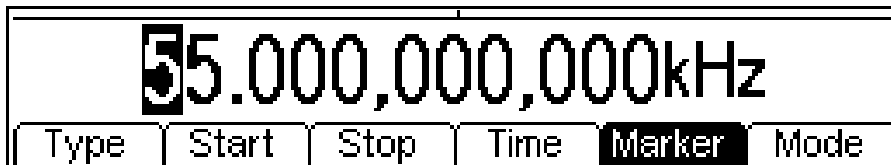

The marker frequency may be changed in either of the ways detailed in General: Numeric Editing.

Sweep Mode

The sweep mode specifies how the sweep will be started. This may be continuous or triggered. The trigger signal for the sweep can be internal from the trigger generator, external from the TRIG IN connector or manual by pressing the TRIGGER key.

To set the mode press the **Mode** soft-key. The mode parameter will appear in the Edit Box.

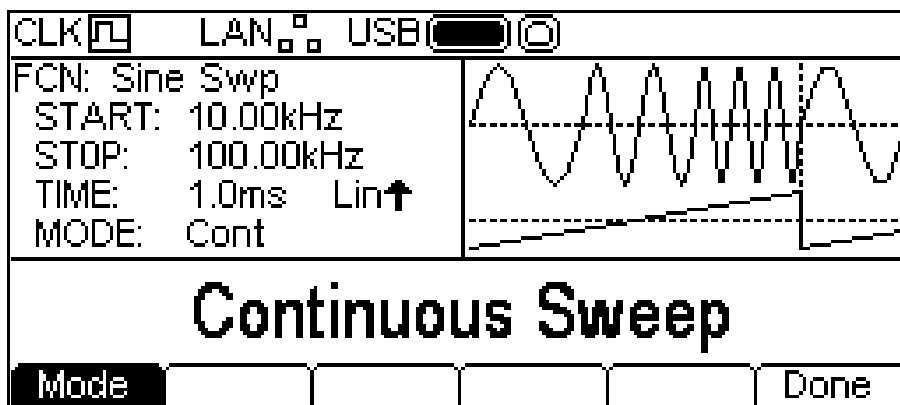

The default mode is Continuous Sweep. In this mode the sweep will proceed to the end and immediately start again with no pause. This is shown in the Graph Box by the sweep type waveform restarting immediately.

Pressing the **mode** soft-key will select the last used trigger mode. The soft-keys will change and a trigger waveform will be added to the Graph Box. The sweep type waveform will also change to show a pause at the end of the sweep. The **MODE** field in the Parameters Box will show the selected trigger mode.

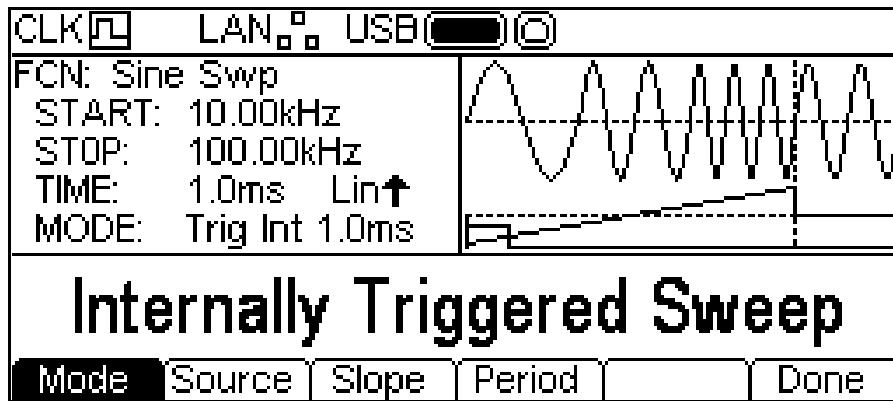

Pressing the **Mode** soft-key again while it is highlighted will return to continuous mode.

Repeated presses of the **Source** key will cycle round the three possible trigger sources: **Internal Trigger** (using the internal trigger generator), **External Trigger** (using the signal at the TRIG IN connector) and **Manual Trigger** (from the TRIGGER key). Internal trigger also has **slope** and **period** keys, external trigger has only a **slope** key and manual trigger has no additional keys.

The **slope** key selects between **Positive Slope** and **Negative Slope**. The trigger waveform in the Graph Box changes to show the edge in use.

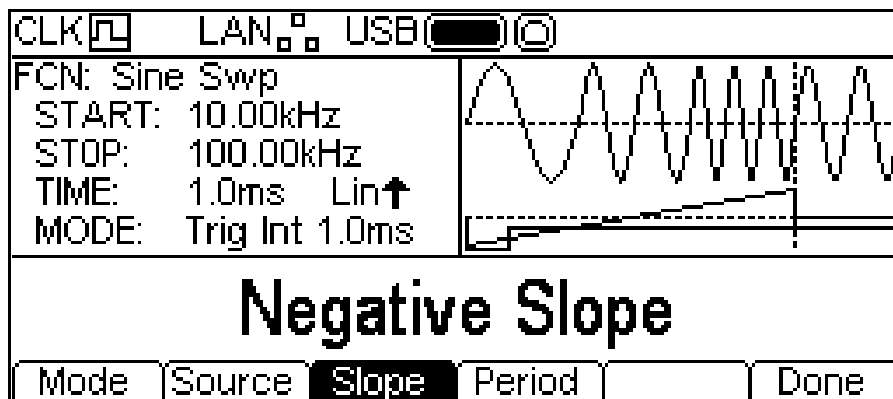

Pressing the **Period** soft-key allows the period of the internal trigger generator to be set. The Edit Box shows the current period and the Graph Box changes to show that the trigger period is being edited.

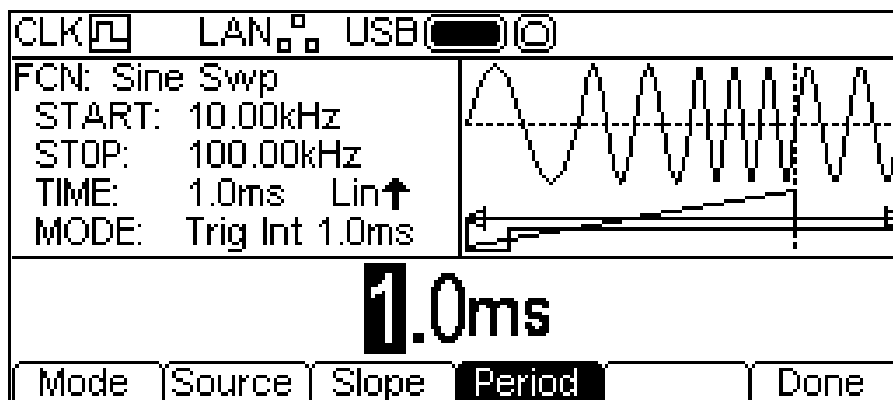

The period may be changed in either of the ways detailed in General: Numeric Editing.

Press the **Done** soft-key to return to the top level Sweep menu.

All the parameters for sweep are now set.

General

All waveforms can be run using the Burst function with the exception of Noise. The burst function allows the carrier waveform to be triggered, produce a user specified number of cycles and then stop and wait for the next trigger.

Alternatively the number of cycles may be Infinite. In this case the trigger starts the waveform and the next trigger stops the waveform.

The Gated Burst function causes the carrier waveform to run while the trigger is true and stop while the trigger is false. The gated function is also available with Noise as the carrier waveform.

In all the above cases, except Noise, the operation will always produce an exact number of cycles of the carrier waveform.

The trigger signal for the burst can be internal from the trigger generator, external from the TRIG IN connector or manual by pressing the TRIGGER key.

Pressing the BURST key will apply the currently selected burst parameters to the currently selected carrier waveform and the BURST key will glow yellow. The screen below shows the effect of pressing the BURST key when sine is the selected waveform.

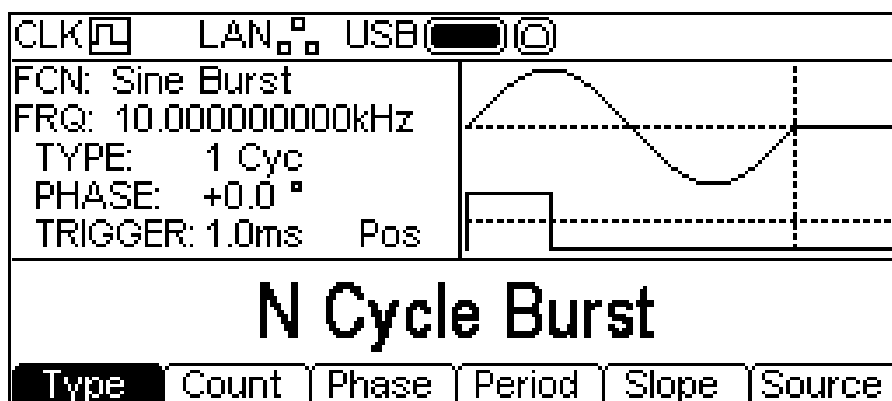

The Parameters Box now shows the current burst parameters of **TYPE**, **PHASE**, and **TRIGGER** and **Burst** is shown in the **FCN** field. The Graph Box shows the burst waveform trigger below a representation of the carrier waveform. The Edit Box contains the selected parameter, in this case type.

To change the carrier waveform parameters press the highlighted carrier waveform key which will return the display to the carrier menu as shown below.

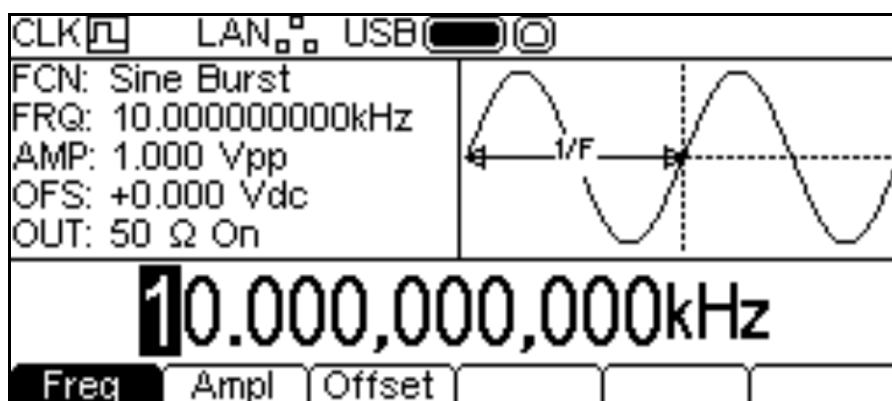

Notice that **Burst** still shows in the **FCN** field of the Parameters Box and the BURST key still glows yellow indicating that burst is still active. To return to the Burst menu to edit the burst parameters press the BURST key again. To turn off burst press the BURST key while the Burst menu is displayed.

The following sections discuss the parameter choices for burst.

Burst Type

To set the burst type press the **Type** soft-key. Each press will select the next type from **N Cycle Burst**, **Infinite Burst** and **Gated Burst**. The currently selected type will appear in the Edit Box, the **TYPE** field in the Parameters Box will show the type and the Graph Box will show the trigger waveform below a representation of the carrier waveform with the burst type applied.

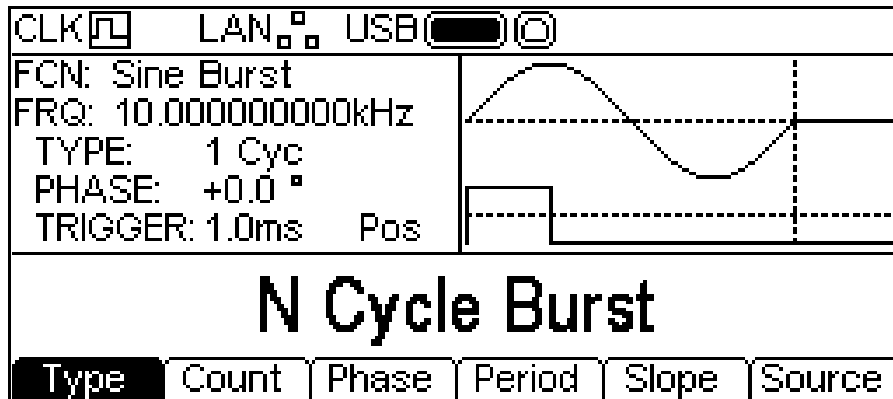

Burst Count

To set the burst count press the **Count** soft-key. The burst count parameter will appear in the Edit Box. Only **N Cycle Burst** has a **Count** soft-key.

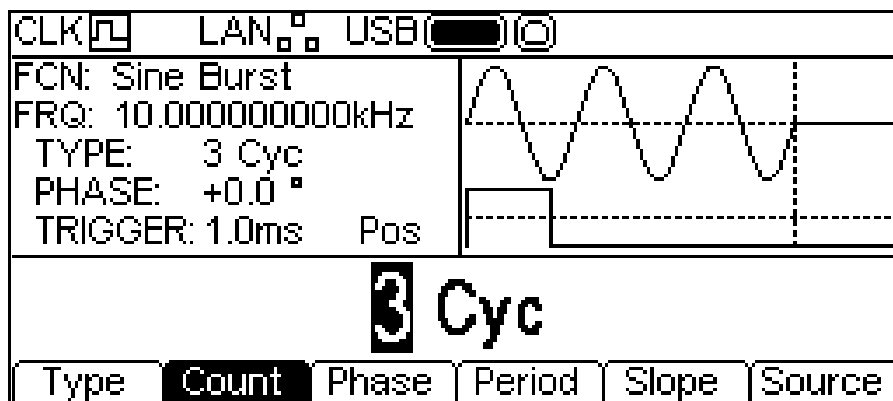

The count may be changed in either of the ways detailed in Numeric Editing Principles. The carrier waveform in the Graph Box will show a representation of the burst as the count is edited.

Burst Phase

To set the carrier start phase press the **Phase** soft-key. The phase parameter will appear in the Edit Box.

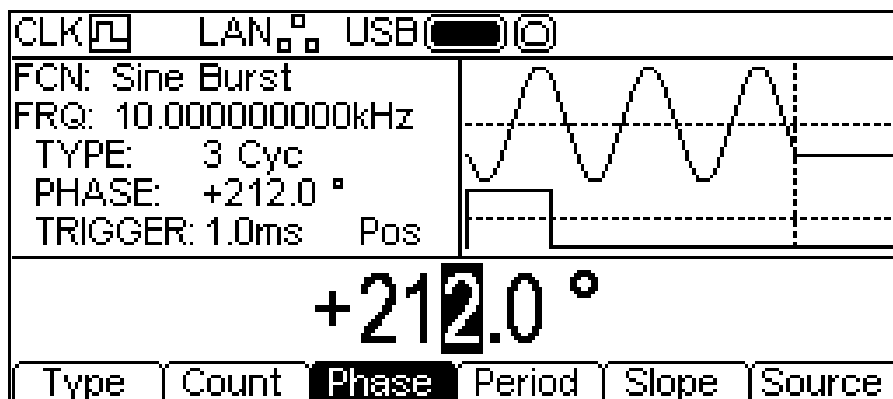

The phase may be changed in either of the ways detailed in General: Numeric Editing. The carrier waveform in the Graph Box will show a representation of the carrier start phase as the phase is edited.

Burst Triggering

The **Source**, **Slope** and **Period** keys allow the burst trigger to be specified. To set the trigger first select a source by pressing the **Source** soft-key which will show the currently selected source in the Edit Box.

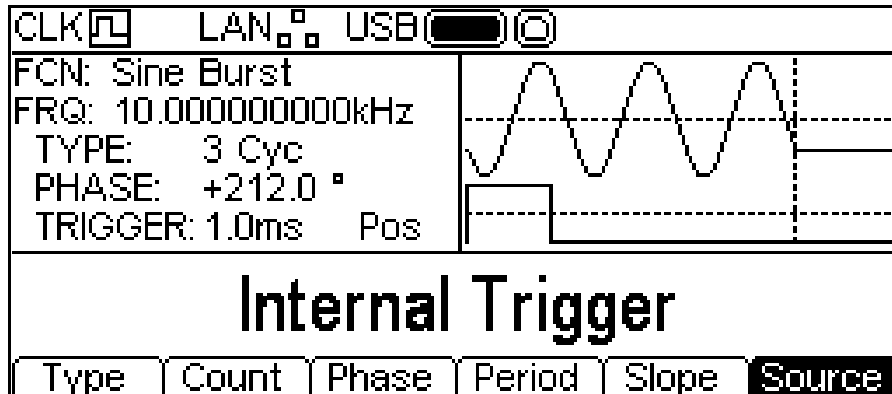

Repeated presses of the **Source** key will cycle round the three possible trigger sources: **Internal Trigger**, **External Trigger** and **Manual Trigger**. Internal trigger also has **slope** and **period** keys, external trigger has only a **slope** key and manual trigger has no additional keys.

The **slope** key selects between **Positive Slope** and **Negative Slope**. The trigger waveform in the Graph Box changes to show the edge in use.

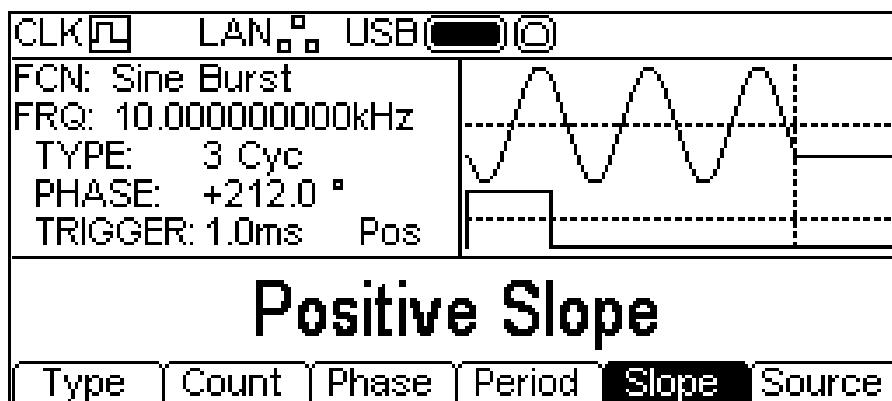

Pressing the **Period** soft-key allows the period of the internal trigger generator to be set. The Edit Box shows the current period and the Graph Box changes to show that the trigger period is being edited.

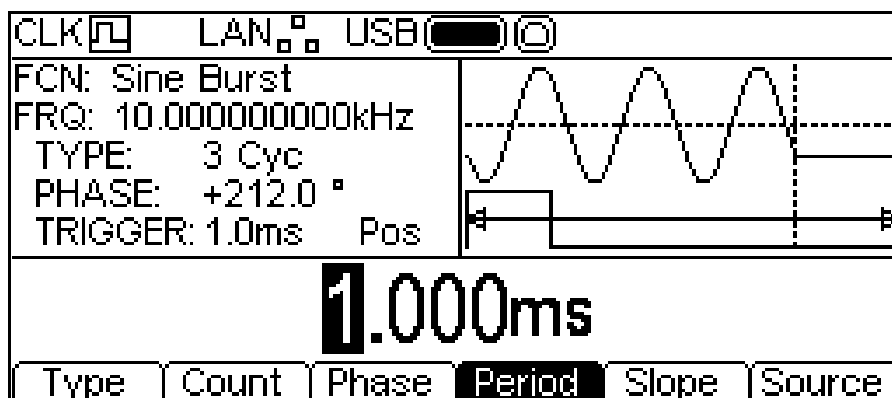

The period may be changed in either of the ways detailed in General: Numeric Editing. All the parameters for burst are now set.

General

Pressing the UTILITY key presents several further menus which allow control of instrument and system capabilities not available directly from the menus described so far.

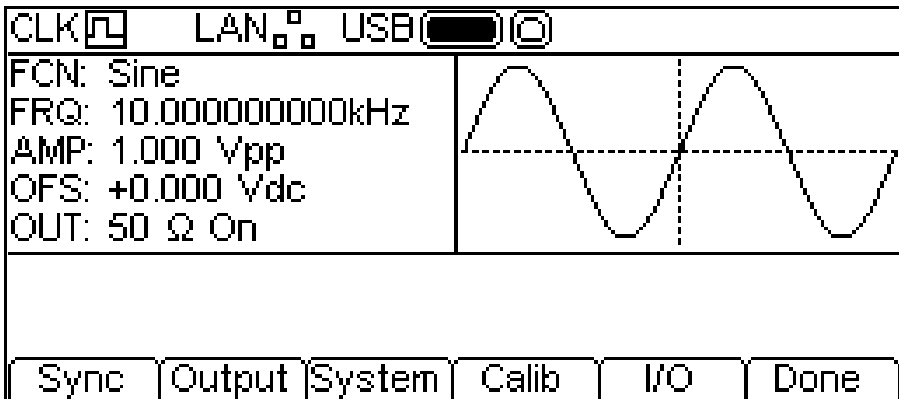

Each of the soft-key selected menus is discussed in the following sections.

Sync Output

Pressing the **sync** key shows the Sync Output menu which controls the signal at the SYNC OUT connector.

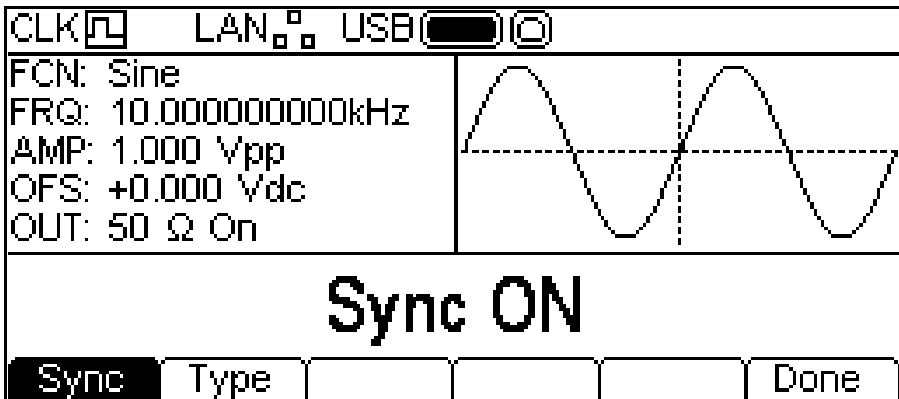

Pressing the **sync** soft-key alternately turns the Sync Output off and on. To set the sync type press the **Type** soft-key. The currently selected type will appear in the Edit Box and the soft-keys will change to a list of sync types available.



The [right arrow] soft-key indicates that there are too many options to show all at once so press this key to show more. In this case there is one more list of types.



One more press of the [right arrow] soft-key will show the first list again. Select the sync type required by pressing the appropriate key then press the [up arrow] soft-key to return to the top level Sync menu or press the UTILITY key to exit the Utility menus.

The available sync types are explained below.

Auto: Automatically sets the most relevant output for the instrument set-up. The chosen type is shown in brackets.

Carrier Sync: A square wave at the same frequency and duty as the carrier waveform. Available for all waveforms except noise.

Modulation Sync: A square-wave at the same frequency as the internal modulation waveform with a duty of 50%. Not available for external modulation.

Sweep Sync: Outputs the sweep trigger and sweep marker signals.

Burst Sync: A square wave coincident with a burst output.

Trigger: A buffered version of the Trigger signal.

Main Output

Pressing the **Output** key shows the Output menu which allows control of the MAIN OUT connector functions.

Range

Pressing the **Range** soft-key will alternate between **Auto** and **Hold**.

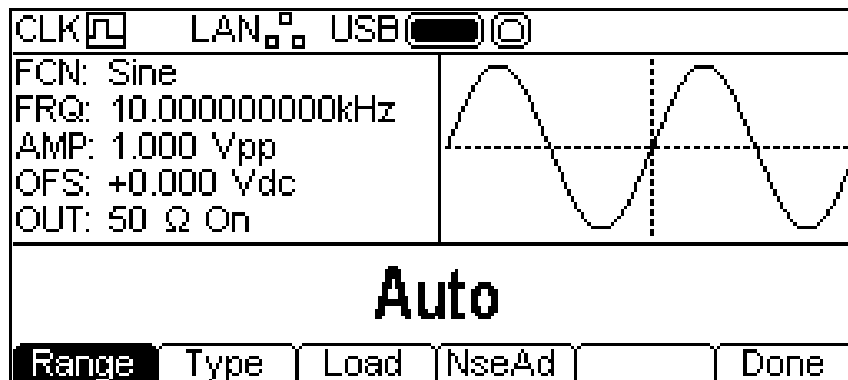

The instrument, by default, automatically selects the optimal settings for the output amplifier and attenuators. This auto-ranging can be disabled and the instrument will use the present amplifier and attenuator settings. Auto-ranging may be disabled to eliminate momentary disruptions in the output waveform caused by switching of the attenuators while changing amplitude. However, turning auto-ranging off has side effects. For example, the amplitude and offset accuracy and resolution (as well as waveform fidelity) may be adversely affected when reducing the amplitude below a range change that would occur with auto-ranging on.

With range set to **Auto** the amplitude and attenuators will switch automatically and optimal performance will be realised.

With range set to **Hold** the current attenuator setting will be held while changing amplitude. The **AMP** field in the Parameters Box will show **AttHld** while range is held.

Type

Pressing the **Type** soft-key will alternate between **Normal** and **Inverse**.

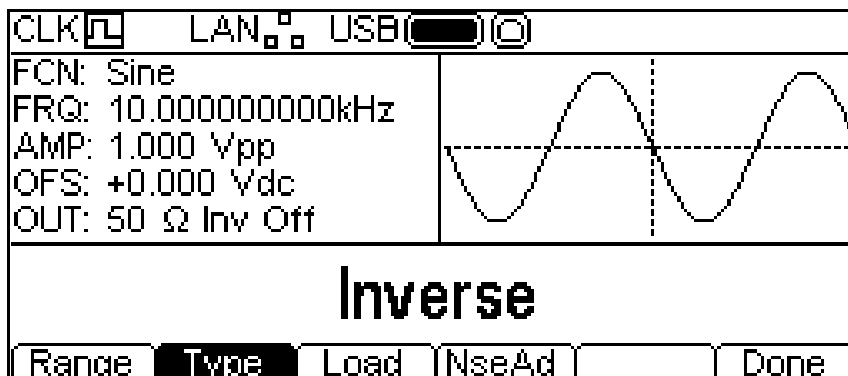

Inverse will invert the carrier waveform at the MAIN OUT connector. This is shown by **Inv** in the **OUT** field of the Parameters Box and the carrier waveform in the Graph Box will be inverted. Inversion is also possible using the +/- key as described in the Continuous Carrier Waveform Operation section.

Load

Pressing the **Load** soft-key will show the current load value in the Edit Box.

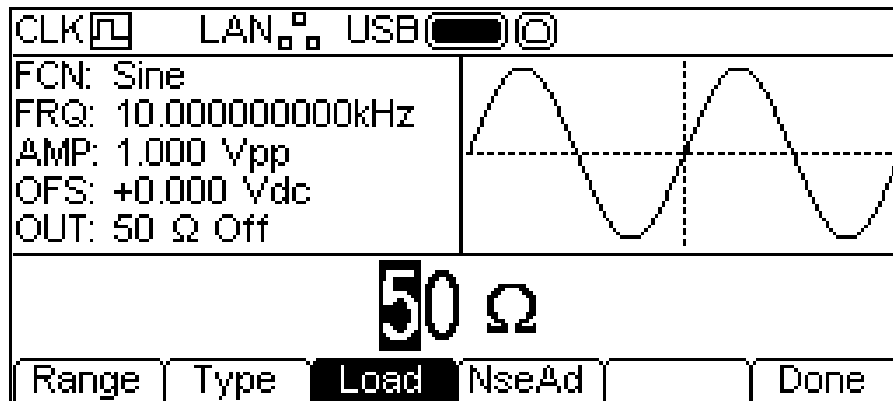

This is the value that is assumed to be loading at the instrument MAIN OUT connector. The value is used to calculate the actual values of amplitude and dc offset. Note that the output impedance of the instrument MAIN OUT connector is fixed at 50Ω.

The value may be changed in either of the ways detailed in General: Numeric Editing.

Pressing the **Load** soft-key will alternate between **High-Z** and the last value entered. With **High-Z** selected the load impedance will be assumed infinite.

Noise Add

Noise may be added to any output waveform except Square, Pulse and Noise. However, it is possible to add noise to the arbitrary square-wave found at **ARB-Load-BuiltIn2-Square**. See the Continuous Carrier Waveform Operation: Arb Load section for more information on built in arbs.

To add noise to the output waveform press the **NseAd** soft-key to show the noise add menu..

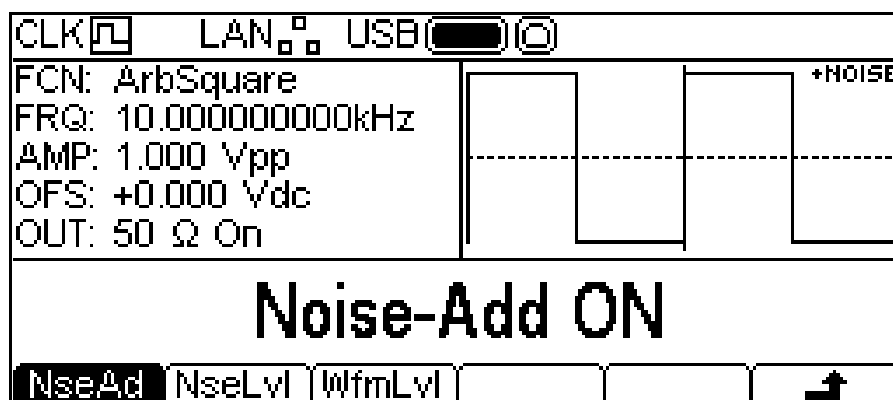

Pressing the **NseAd** soft-key will alternate between **Noise-Add ON** and **Noise-Add OFF**. With noise added the Graph Box shows **+NOISE** in the top right corner and two extra soft-key labels appear, **NseLvl** and **WfmLvl**.

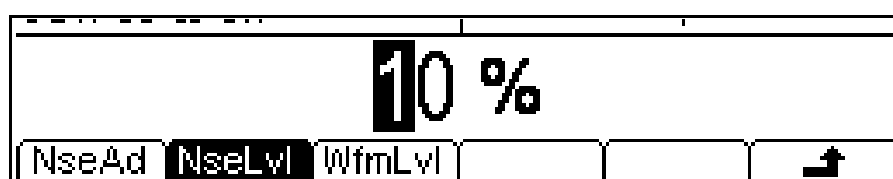

Pressing the **NseLv1** key allows the noise percentage to be set. Pressing the **WfmLv1** key allows the Waveform percentage to be set. These parameters may be changed in either of the ways detailed in General: Numeric Editing. Using the two parameters the ratio may be set anywhere in the range 50% waveform and 50% noise to 99% waveform and 1% noise.

Press the **↩** soft-key to return to the top level output menu or press the **UTILITY** key to exit the utility menus.

System

Pressing the **system** soft-key gives control of some system level functions.

Power On State

Pressing the **PwrOn** soft-key will alternate between **Power-On Default** and **Power-On Latest**.

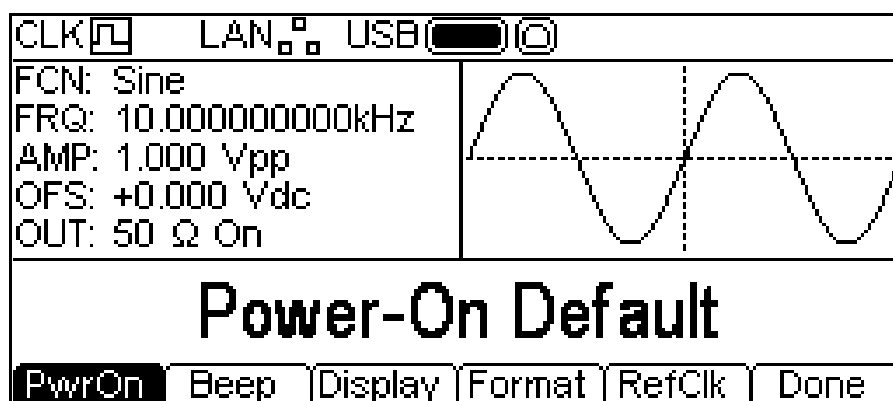

With **Power-On Default** selected the instrument will power up with the factory default parameters loaded.

With **Power-On Latest** selected the instrument will power up with the parameters as they were at the last power down.

Beep State

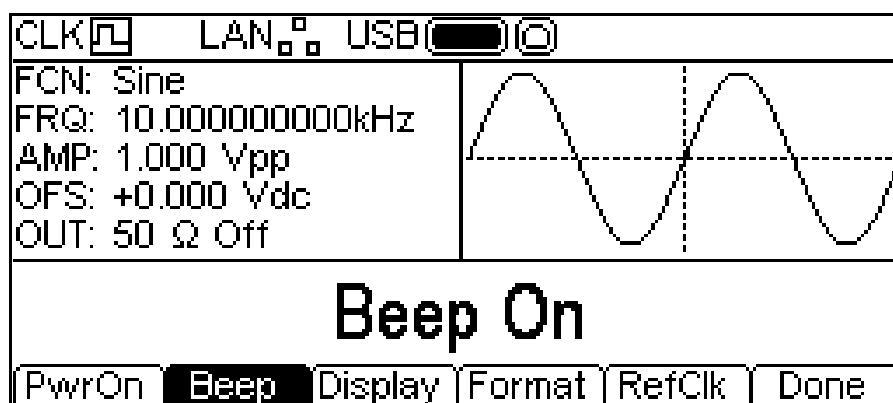

Pressing the **Beep** soft-key will alternate between **Beep ON** and **Beep Off**. With beep on the error and warning messages will be accompanied by a sound. These sounds are suppressed with beep off.

Display Control

Pressing the **Display** soft-key will show the display control menu.

Pressing the **Contra** soft-key allows the display contrast to be adjusted. The parameter may be changed in either of the ways detailed in General – Numeric Editing.

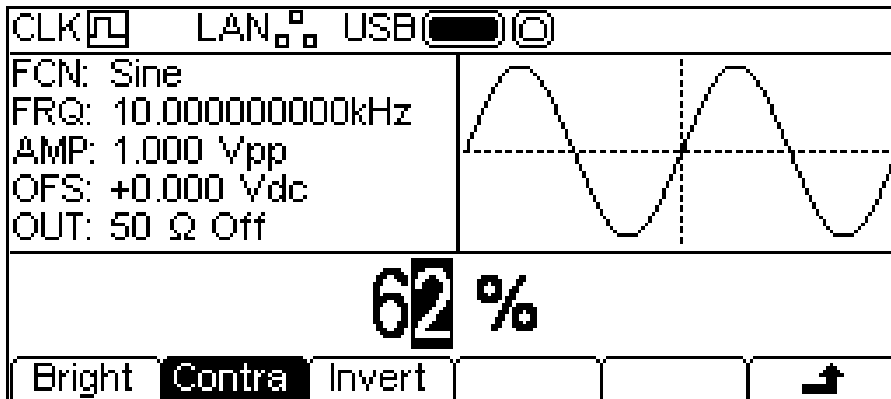

Pressing the **Bright** soft-key allows the display backlight brightness to be adjusted. The parameter may be changed in either of the ways detailed in General: Numeric Editing.

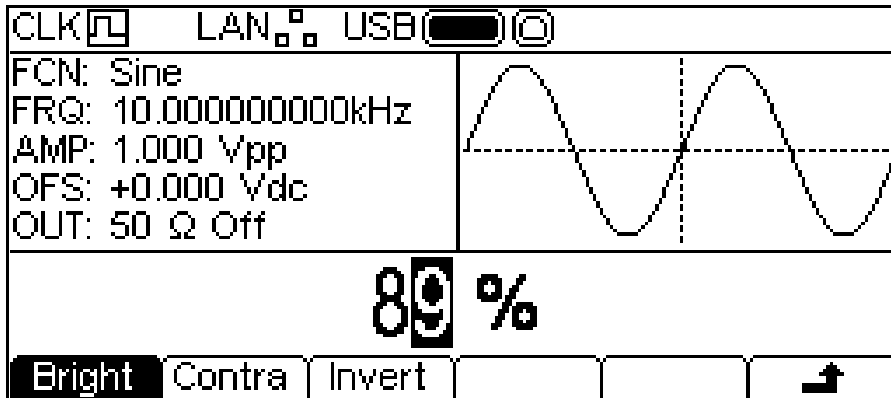

Pressing the **Invert** soft-key will alternately set the display between black-on-white (the default) and white-on-black .

Press the **↑** soft-key to return to the top level System menu or press the UTILITY key to exit the Utility menus.

Number Format

Pressing the **Format** soft-key will show the Format menu.

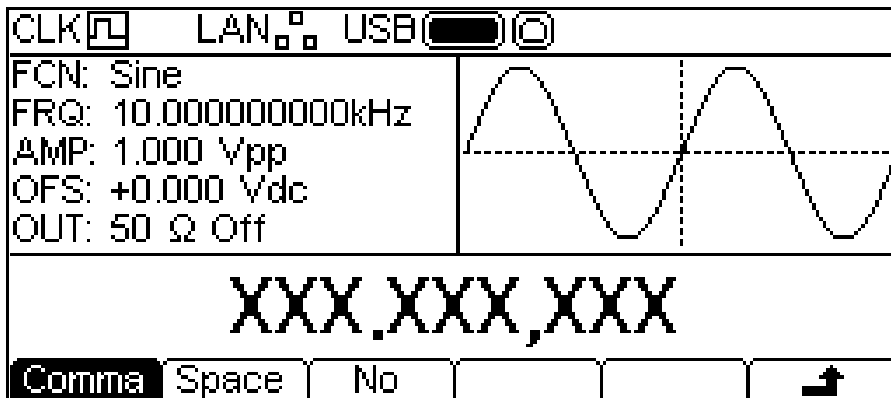

This menu allows the number format used in the Edit Box to be customised. The default is comma format which is selected by pressing the **Comma** soft-key. In comma format, digits after the decimal point are arranged in groups of three with the groups separated by a comma. Pressing the **Space** soft-key will change to space format.



In space format digits after the decimal point are arranged in groups of three with the groups separated by a space. Pressing the **No** soft-key will change to no format.







In no format digits after the decimal point are not grouped.

Press the  soft-key to return to the top level system menu or press the UTILITY key to exit the utility menus.

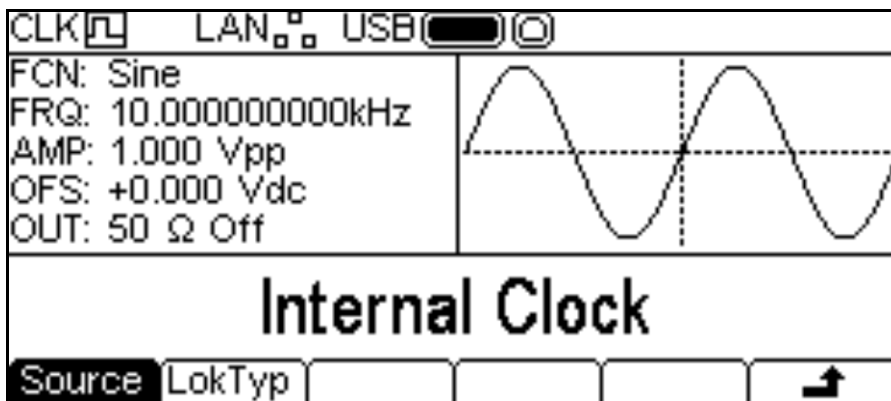
Reference Clock Control

Pressing the **RefClk** soft-key will show the reference clock selection menu.



Pressing the **Source** soft-key will alternately select between **Internal Clock** or **External Clock**. With internal clock selected the instrument will use its internal TCXO as the timing reference for the creation of all waveforms. With external clock selected the signal present at the 10MHz REF IN connector will be used, if it is valid, and the Status Line will show **CLK**  . If the signal at the 10MHz REF IN connector is invalid or not present the warning message **External clock invalid Generator running on internal clock** will pop up and the Status line will show **CLK**  indicating that the generator is running on internal clock. When a valid clock is connected the instrument will use it and pop up the message **External clock detected Generator running on external clock**. If a noisy or otherwise out-of-specification signal is present at the 10MHz REF IN connector the instrument may alternate between the two messages.

Pressing the **LokTyp** soft-key gives access the multi-instrument synchronising capabilities of the instrument.

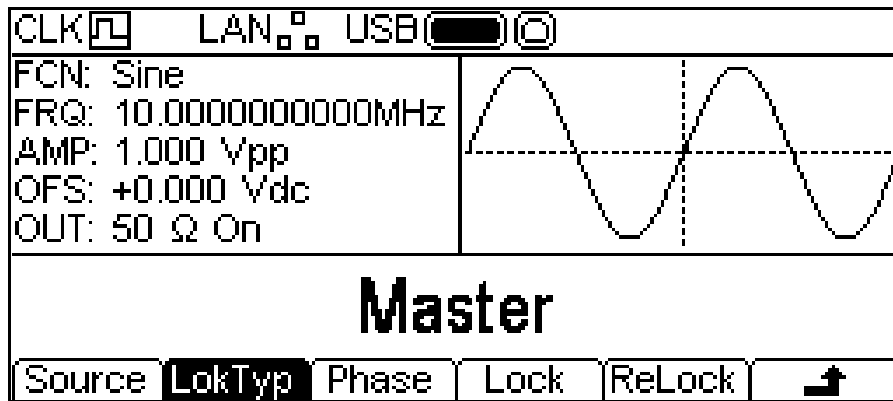

See the Synchronising Two Generators section for details of these options.

Calibration

Pressing the **Calib** soft-key shows the opening screen for instrument calibration.

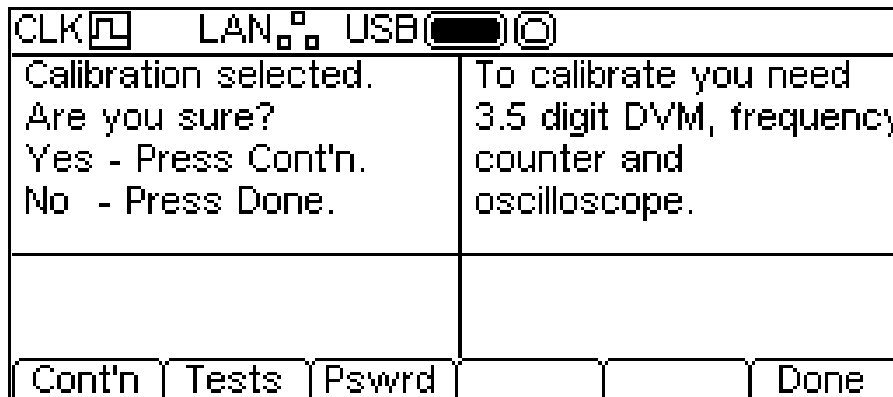

Full details on calibration may be found in the Calibration section.

I/O

Pressing the **I/O** soft-key shows the remote interface menu. This allows activation and control of the installed interfaces.

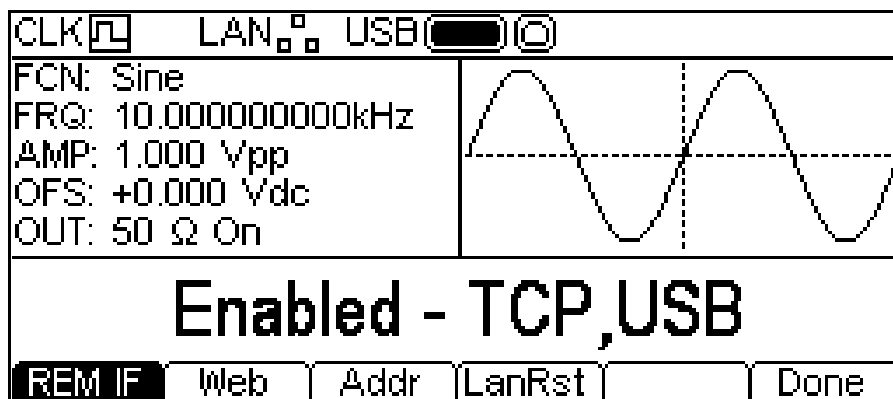

See the Remote Control section for full details of the use of the interfaces.

General

The stores menu gives access to both the instrument's local storage of arbitrary waveforms and parameter set-ups and the external storage of a connected USB flash drive. There are facilities for saving and recalling set-ups to and from local stores, deleting set-ups and arbitrary waveforms and copying waveform and set-up files to and from a USB flash drive. It is possible to save a waveform from a PC to a USB flash drive and then copy the waveform into the instrument for playback.

Flash Drive Files and Folders

The instrument uses the folder called \ARB for all file storage. This folder contains up to three more folders used as follows:

1. \ARB\WAVES. This folder is used to store waveforms. It is the only place where the instrument will look for waveform files. A waveform file has a file extension of .WFM. Files with any other extension will be ignored.
2. \ARB\SETUPS. This folder is used to store set-ups. It is the only place where the instrument will look for set-up files. A set-up file has a file extension of .SU. Files with any other extension will be ignored.
3. \ARB\FW5011. This folder, if present, is used to store instrument firmware updates. This is the only place where the instrument will look for firmware update files. There are several types of file that may be in this folder. They should not be tampered with as they are checked by the firmware during use and, if corrupt, could render the instrument non-functional. After a successful update it is safe to delete the files in this folder. This option is offered by the boot-loader code in the instrument.

The instrument is able to read and write flash drives formatted FAT16 or FAT32. The instrument does not generate or use long filenames. A filename can only be up to eight characters in length. When a new flash drive is attached to the instrument the required folders will be created automatically.

Using the Stores Menu

Pressing the STORES key will show the stores menu.

The screenshot shows the Stores Menu interface. At the top, there are status indicators for CLK, LAN, and USB. Below this, there are two main panels: 'Local: Setups' on the left and 'Disk: Setups' on the right. Each panel has a list of files with a selection arrow pointing to the first item. At the bottom, there are six soft-key labels: Wave, Disk, Copy, Save, Recall, and Delete.

Local: Setups		Disk: Setups	
➔ SETUP1	3002	➔ SETUP1	3002
2 SETUP2	Empty	SETUP3	3002
3 SETUP3	Empty		
4 SETUP4	Empty		
5 SETUP5	Empty		

Wave | Disk | Copy | Save | Recall | Delete

Note that there are now two screen boxes between the Status Line and the Soft-key Labels. The **Local:** Box on the left contains a list of appropriate local files. The **Disk:** Box on the right contains a list of the appropriate files on an attached USB flash drive. If no flash drive is attached the list will read **Please insert the disk**. It is not necessary to attach a flash drive for local only operations.

The top line of each box indicates which file type that the list contains and one box has ➔ (the selection arrow) pointing at the top line. The lists both show ➔ pointing at their selected file. One box is selected and one file from each list is selected. Moving the three selection arrows around defines the file or files that will be operated on by soft-key presses and the direction that data will flow between the files. More information on selections and operations appears in the following sections.

The files are listed by name and the number indicates the size of the file in bytes for a set-up file or the number of points in a waveform file.

There are nine local set-up stores and four local arbitrary waveform stores. The respective lists always show all of the stores even if they are empty. An empty store shows **Empty** instead of a size.

Press the STORES key to exit from the stores menu.

Selections

The first soft-key selects between waveforms and set-ups. When Waveforms are shown the key will be labelled **Setup** and when set-ups are shown the key will be labelled **Wave**.

CLK []		LAN []		USB []	
➔ Local: Waveforms			Disk: Waveforms		
➔	ARB1	4	➔	ARB3	4
2	ARB2	4		CARDIAC	4096
3	ARB3	4		GAUSSIAN	4096
4	ARB4	4		HAVERS~1	4096
				LORENTZ	4096
Setup	Disk	Copy			Delete

The second soft-key selects between local and disk. When the selection arrow is in the **Local:** Box the key will be labelled **Disk** and when the selection arrow is in the **Disk:** Box the key will be labelled **Local**.

The file selection arrows are moved by first selecting the required box, as above. A file is then selected by turning the KNOB until the selection arrow is next to the required filename. If there are more files than will fit on the screen the list will scroll when the arrow reaches the top or bottom of the box.

Operations on Set-up Files

To operate with set-ups ensure that the set-up files are shown by pressing the **Setup** soft-key.

CLK []		LAN []		USB []	
➔ Local: Setups			Disk: Setups		
➔	SETUP1	3002	➔	SETUP1	3002
2	SETUP2	Empty		SETUP3	3002
3	SETUP3	Empty			
4	SETUP4	Empty			
5	SETUP5	Empty			
Wave	Disk	Copy	Save	Recall	Delete

There are nine local set-up stores numbered 1 to 9. The number is shown next to the filename in the **Local:** Box. Initially the files will all be empty. The file names are **SETUP1** to **SETUP9** by default but they may be changed as they are used.

There are four operations available for set-up files as shown by the soft-key labels **Copy**, **Save**, **Recall** and **Delete**. The copy operation will not be available if no flash drive is attached.

Copy

The copy operation allows set-up files to be copied between local storage and an attached USB flash drive.

To copy a file from local to disk:

1. Select the **Local**: Box by pressing the **Local** soft-key.
2. Select the file to be copied.
3. Press the **Copy** soft-key.
4. Optionally modify the name of the file to receive the copy. This will default to the name of the file selected in step 2 above if it is not modified.

The screen below shows an example after performing the above actions. Here the file in store 3 will be saved to a set-up file on disk. The name will be **SETUP3** unless it is changed.

CLK	LAN	USB			
➔ Local: Setups	Disk: Setups				
1 SETUP1 3002	➔ SETUP1 3002				
2 SETUP2 Empty	SETUP14 3002				
➔ SETUP3 3002	SETUP3 3002				
4 SETUP4 Empty					
5 NEW 3002					
Wave	Disk	Copy	Save	Recall	Delete

Pressing the **Copy** soft-key will then show the following:

CLK	LAN	USB		
Copy from: Local	Copy to: Disk			
Setup: SETUP3	Setup: SETUP3			
Size: 3002	Size: 3002			
Edit Name: SETUP3				
	DelChar	Default	Cancel	Execute

The **Copy from:** Box shows that the source is **Local** and shows the file to be copied. The **Copy to:** Box shows the file that will be written to **Disk**. The Edit Box shows the name of the file that will be written and the soft-key labels, KNOB and cursor keys allow the name to be edited.

The **DelChar** key allows characters to be deleted from either end of the name but not from the centre.

The **Default** soft-ket displays the name of the source file again.

The **Cancel** key cancels the copy operation and returns to the top level stores menu.

The **Execute** soft-key starts the copy operation and returns to the top level Stores menu when complete.

The cursor keys will move the edit cursor through the name and turning the KNOB will cycle through all valid characters, numbers and symbols.

To copy a file from disk to local:

1. Select the **Local**: Box by pressing the **Local** soft-key.
2. Select the local store to receive the file from disk.
3. Select the **Disk** Box by pressing the **Disk** soft-key.
4. Select the file to be copied.
5. Press the **Copy** soft-key.
5. Optionally modify the name of the local store to receive the copy. This will default to the name of the file selected in step 4 above if it is not modified.

The screen below shows an example after performing the above actions. Here the set-up in store 3 will be overwritten by the disk file **SETUP14**.

CLK []	LAN []	USB []	[]	[]
Local: Setups		Disk: Setups		
1	SETUP1	3002	NEW	3002
2	SETUP2	Empty	SETUP1	3002
➔	SETUP3	3002	➔ SETUP14	3002
4	SETUP4	Empty	SETUP3	3002
5	NEW	3002		
Wave	Local	Copy		

Pressing the **Copy** soft-key will then show the following.

CLK []	LAN []	USB []	[]	[]
Copy from: Disk		Copy to: Local		
Setup:	SETUP14	Setup:	SETUP14	
Size:	3002	Size:	3002	
Edit Name:		SETUP14		
		DelChar	Default	Cancel Execute

The **Copy from**: Box shows that the source is **Disk** and shows the file to be copied. The **Copy to**: Box shows the file that will be written to the **Local** store. The Edit Box shows the name of the file that will be written and the soft-key labels, KNOB and cursor keys allow the name to be edited.

The **DelChar** key allows characters to be deleted from either end of the name but not from the centre.

The **Default** soft-key displays the name of the source file again.

The **Cancel** key cancels the copy operation and returns to the top level Stores menu.

The **Execute** soft-key starts the copy operation and returns to the top level Stores menu when complete

The cursor keys will move the edit cursor through the name and turning the KNOB will cycle through all valid characters, numbers and symbols.

Save

The save operation allows the current instrument set-up to be saved to a local set-up store. Save will function with or without an attached USB flash drive.

To perform a save operation first select the set-up store for the current instrument state to be saved to.

Pressing the **save** soft-key will show a screen similar to that below.

CLK	LAN	USB	
Save: Current Settings		Save to: Local	
		Setup: SETUP2	
		Size: 3002	
Edit Name:		SETUP2	
		DelChar	Default
		Cancel	Execute

The name offered will be the same as the name in the selected set-up store when the **save** soft-key was pressed. The Edit Box shows the name of the file that will be saved and the soft-key labels. KNOB and cursor keys allow the name to be edited.

The **DelChar** key allows characters to be deleted from either end of the name but not from the centre.

The **Default** soft-key displays the name of the source file again.

The **Cancel** key cancels the save operation and returns to the top level Stores menu.

The **Execute** soft-key starts the save operation and returns to the top level Stores menu when complete.

The cursor keys will move the edit cursor through the name and turning the KNOB will cycle through all valid characters, numbers and symbols.

Recall

The recall operation allows the current instrument set-up to be replaced with the set-up from a local store. Recall will function with or without an attached USB flash drive.

To perform a recall operation first select the set-up store containing the instrument state to recall.

Pressing the **Recall** soft-key will then recall the data and load it as the current instrument set-up.

Delete

The delete operation allows the set-up in the selected store to be deleted. The store will then be marked empty.

Operations on Waveform Files

To operate with waveforms ensure that the waveform files are shown by pressing the **Wave** soft-key.

CLK	LAN	USB	
➔ Local: Waveforms		Disk: Waveforms	
➔ ARB1	4	➔ ARB3	4
2 ARB2	4	CARDIAC	4096
3 ARB3	4	GAUSSIAN	4096
4 ARB4	4	HAVERS-1	4096
		LORENTZ	4096
Setup	Disk	Copy	Delete

There are four local arbitrary waveform stores numbered 1 to 4. The number is shown next to the file name in the **Local**: Box. Initially the files are all set to the default four point square-wave. The file names are set as **ARB1** to **ARB4** by default but they may be changed as they are used.

Each arbitrary waveform store can hold a waveform with a maximum of 65536 points. It is also possible to store a waveform of up to 131072 points in stores 1 or 3. In this case waveforms 2 or 4 will be deleted and will show as below.

Local: Waveforms		Disk: Waveforms	
➔	ARB1 100000	➔	ARB3 4
2	*****		CARDIAC 4096
3	ARB3 4		GAUSSIAN 4096
4	ARB4 4		HAVERS~1 4096
			LORENTZ 4096
Setup	Disk	Copy	Delete

There are two operations available for waveform files as shown by the soft-key labels **Copy** and **Delete**. The copy operation will not be available if no USB flash drive is attached.

Copy

The copy operation allows waveform files to be copied between local storage and an attached USB flash drive.

To copy a file from local to disk:

1. Select the **Local**: Box by pressing the **Local** soft-key.
2. Select the file to be copied.
3. Press the **Copy** soft-key.
4. Optionally modify the name of the file to receive the copy. This will default to the name of the file selected in step 2 above if it is not modified.

The screen below shows an example after performing the above actions. Here the file in store 3 will be saved to a waveform file on disk. The name will be **ARB3** unless it is changed.

Local: Waveforms		Disk: Waveforms	
1	ARB1 4	➔	CARDIAC 4096
2	ARB2 4		GAUSSIAN 4096
➔	ARB3 4		HAVERS~1 4096
4	ARB4 4		LORENTZ 4096
Setup	Disk	Copy	Delete

Pressing the **Copy** soft-key will then show the following.

CLK [] LAN [] USB []	
Copy from: Local	Copy to: Disk
Waveform: ARB3	Waveform: ARB3
Points: 4	Points: 4
Edit Name: ARB3	
	DelChar Default Cancel Execute

The **Copy from:** Box shows that the source is **Local** and shows the file to be copied. The **Copy to:** Box shows the file that will be written to disk. The Edit Box shows the name of the file that will be written and the soft-key labels. KNOB and cursor keys allow the name to be edited.

The **DelChar** key allows characters to be deleted from either end of the name but not from the centre.

The **Default** soft-key displays the name of the source file again.

The **Cancel** key cancels the copy operation and returns to the top level Stores menu.

The **Execute** soft-key starts the copy operation and returns to the top level Stores menu when complete.

The cursor keys will move the edit cursor through the name and turning the KNOB will cycle through all valid characters, numbers and symbols.



To copy a file from disk to local:

1. Select the **Local:** Box by pressing the **Local** soft-key.
2. Select the local store to receive the file from disk.
3. Select the **Disk:** Box by pressing the **Disk** soft-key.
4. Select the file to be copied.
5. Press the **Copy** soft-key.
6. Optionally modify the name of the file to receive the copy. This will default to the name of the file selected in step 4 above if it is not modified

The screen below shows an example after performing the above actions. Here the waveform in store 4 will be overwritten by the disk file GAUSSIAN.

CLK [] LAN [] USB []	
Local: Waveforms	➔ Disk: Waveforms
1 ARB1 4	ARB3 4
2 ARB2 4	CARDIAC 4096
3 ARB3 4	➔ GAUSSIAN 4096
➔ ARB4 4	HAVERS~1 4096
	LORENTZ 4096
Setup	Local Copy

Pressing the **Copy** soft-key will then show the following.

CLK  LAN  USB 	
Copy from: Disk	Copy to: Local
Waveform: GAUSSIAN	Waveform: GAUSSIAN
Points: 4096	Points: 4096
Edit Name:	GAUSSIAN
	DelChar Default Cancel Execute

The **Copy from:** Box shows that the source is **Disk** and shows the file to be copied. The **Copy to:** Box shows the file that will be written to the local store. The Edit Box shows the name of the file that will be written and the soft-key labels. KNOB and cursor keys allow the name to be edited.

The **DelChar** key allows characters to be deleted from either end of the name but not from the centre.

The **Default** soft-key displays the name of the source file again.

The **Cancel** key cancels the copy operation and returns to the top level Stores menu.

The **Execute** soft-key starts the copy operation and returns to the top level Stores menu when complete.

The cursor keys will move the edit cursor through the name and turning the KNOB will cycle through all valid characters, numbers and symbols.

Delete

The delete operation allows the waveform in the selected store to be deleted. The store will contain the default four point square-wave after waveform deletion.

Help Operations

General

The instrument has a comprehensive help system which allows easy access to any Help page. It is possible to get help in two ways:

1. Help menu. Press the HELP key to access a list of help topics which give general information about instrument operations.
2. Context sensitive help. Press and hold down any key, including soft-keys, for two seconds to access the Help page for that key.

There are two types of help screen.

1. The Help menu. This is the screen that gives a list of general help topics.
2. The Help topic screen. This is the screen that displays actual help texts.

The HELP key glows yellow while any Help screen is shown. Pressing the HELP key while it is glowing yellow will exit from the Help menu or topic and return to the screen from which help was initiated. The following sections discuss these two screen types.

Help menu

Pressing the HELP key will display the Help menu.



The Help menu uses all the screen space between the Status Line and the Soft-key Labels and contains a list of help topics. To show a topic use the ← and → soft-keys to move the highlight back or forward through the list to select the required topic, then press the **Select** soft-key to show the topic screen.

Press the ↑ soft-key to exit from the Help menu.

Help Topics

Selecting a Help topic from the Help menu or initiating context sensitive help will show a Help topic screen similar to that shown below.

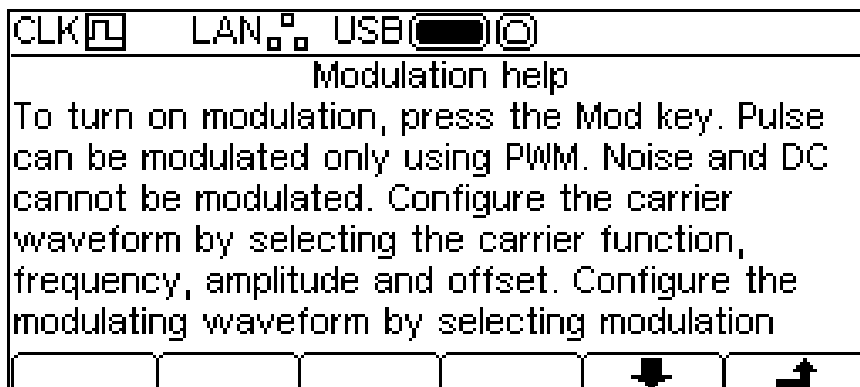

Below the topic heading is the topic text. If there is more text than will fit on the screen press the ↓ soft-key to scroll the text up one line. Continue scrolling until there is no more text indicated by the ↓ soft-key label disappearing. Once the text has been scrolled the ↑ soft-key may be used to scroll the text up one line. Pressing the ↑ soft key will return to the previous screen.

Editing Arbitrary Waveforms

General

The instrument contains some basic editing capabilities for arbitrary waveforms. The supplied Waveform Manager Plus Version 4 Windows application may be used when more comprehensive capabilities for creation and editing are required. Waveforms created in Waveform Manager Plus may be downloaded to the instrument via a remote control interface or they may be transferred using a USB flash drive.

Selecting an Arbitrary Waveform for Editing

To use the instrument to edit an existing arbitrary waveform press the ARB key then press the **Edit** soft-key. The existing arbitrary waveforms appear on the first four soft-keys with the currently selected one highlighted; the name and length are shown in the Edit Box and the selected arb is shown in the Graph Box.



Select the required waveform then press the **Edit** Soft-key to show the edit menu.

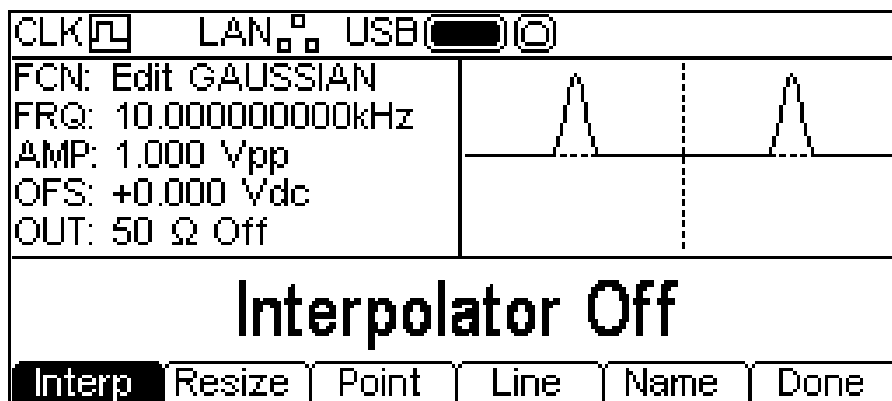

While editing an arbitrary waveform it will be available at the MAIN OUT connector for display on an oscilloscope. There is also a representation shown in the Graph Box and the **FCN** field in the Parameters Box shows **Edit ARBNAME** as a reminder that this waveform is temporarily selected for output.

Editing an Arbitrary waveform

There are five editing options for arbitrary waveforms.

Interpolation

Interpolation is toggled on and off by the **Interp** soft-key. Although the instrument can handle arbitrary waveforms of any length they are always played back using DDS. This requires that they must be forced to a suitable length. The instrument can play a waveform of either 16384 points (16k) or 131072 points (128k). If a waveform is less than or equal to 16k points it will be played back using 16k points, if it greater than 16k points it will be played back using 128k points. So in order to play the waveform it may be necessary to expand it. This expansion may be performed in 2 possible ways. Either the extra points may be created by repeating the same points or linear interpolation may be used.

The **Interp** soft-key allows the type of expansion to be specified. With **Interpolator Off** selected points will be repeated, this is most appropriate for waveforms with fast rising or falling edges. With **Interpolator On** selected linear interpolation will be used as points are added, this is most appropriate for waveforms which are more sinusoidal in nature. For a truly complex waveform it should be created with either 16k or 128k point so that expansion is not required.

Resizing a waveform

A waveform may have its length changed by using the resize option. When a waveform is increased in size new points are added between existing points. The way that the values of these new points are calculated depends on the resize method setting, see below. When a waveform is reduced in size points are simply dropped to achieve the new length.

Pressing the **Resize** soft-key will show the resize menu in the Edit Box and the soft-keys will show the resize options.



The **No.Pts** soft-key allows the new size to be specified. The number of points may be changed in either of the ways detailed in General: Numeric Editing. Press the **Execute** soft-key to resize the waveform and return to the top level edit menu. Pressing the **↑** soft-key will return without resizing.

Pressing the **Method** soft-key will allow the resize method to be set.



When a waveform is increased in size new points are added between existing points. The way that the values of these new points are calculated depends on the resize method setting. The **Repeat Points** method adds points of the same value as the original point in the waveform. The **Interpolate** method draws a straight line between the existing points.

When a waveform is reduced in size points are simply dropped to achieve the new length and the resize method setting has no effect.

Point Editing

Pressing the **Point** soft-key shows the point edit menu in the Edit Box.

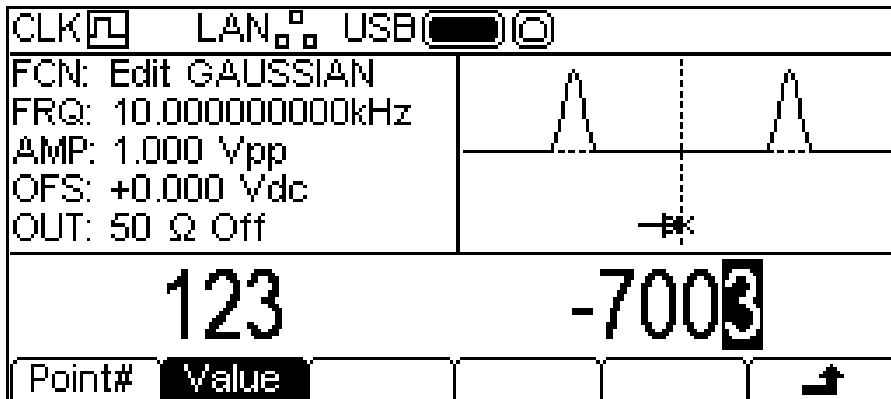

The point edit menu allows individual points in the waveform to be set to any vertical level value. The **Point#** soft-key selects setting of the point number; pressing the **Value** soft-key then enables the value to be changed. The point number and point value may be changed in either of the ways detailed in General: Numeric Editing. The point which is being edited is shown in the Graph Box by an arrow and a **x**. The point value is changed in the actual waveform immediately it is edited.

Line Drawing

Pressing the **Line** soft-key shows the line edit menu in the Edit Box.

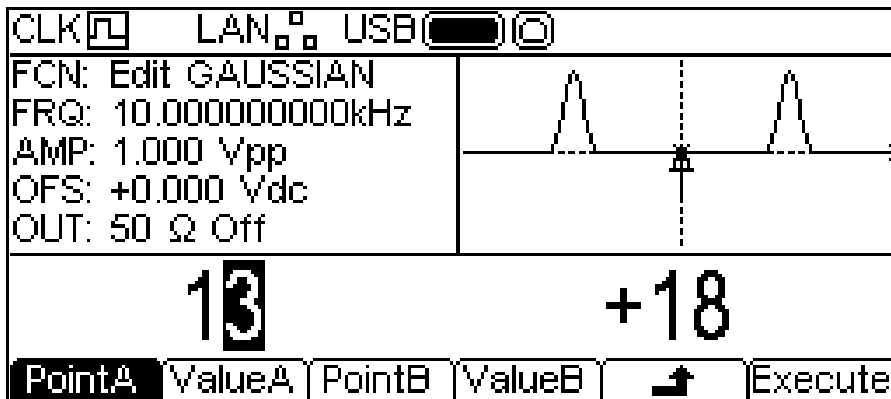

The Line edit menu allows a line to be drawn between any two points in the waveform. The end points of the line may be set to any vertical level value. The **PointA** soft-key selects setting of the first point number; pressing the **ValueA** soft-key then enables the value to be changed. The **PointB** and **ValueB** soft-keys are used to set the second point. The point numbers and point values may be changed in either of the ways detailed in General: Numeric Editing. The point which is being edited is shown in the Graph Box by an arrow and a **x**. The line is drawn in the actual waveform by pressing the **Execute** soft-key after which the instrument will return to the top level edit menu.

Pressing the **↩** soft-key will return without drawing the line.

Naming a Waveform

Pressing the **Name** soft-key shows the name edit menu in the Edit Box.

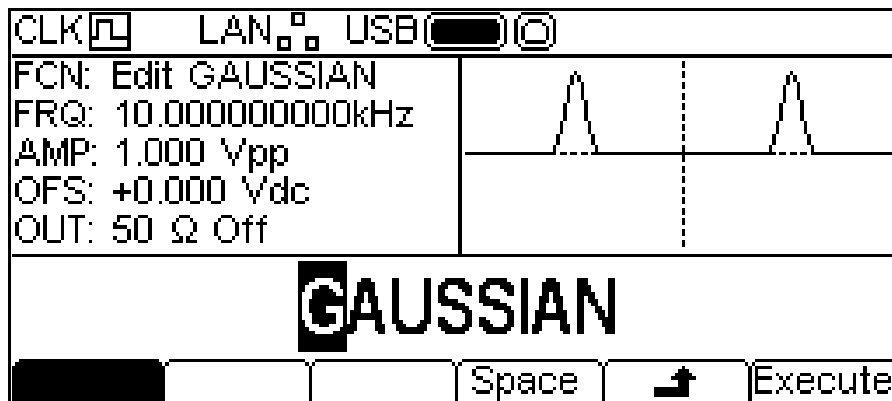

The soft-key labels, KNOB and cursor keys allow the name to be edited.

The **Space** soft-key enters a space character at the cursor position.

The **↕** soft-key cancels the operation and returns to the top level edit menu.

The **Execute** soft-key changes the name and returns to the top level edit menu when complete

The cursor keys will move the edit cursor through the name and turning the KNOB will cycle through all valid characters, numbers and symbols.

Synchronising Two Generators

Two generators can be synchronised together following the procedure outlined below. It is possible to link more than two generators in this way but results are not guaranteed.

Synchronising Principles

Frequency locking is achieved by using the clock output from the master generator to drive the clock input of a slave. The additional connection of an initialising SYNC signal permits the slave to be synchronised such that the phase relationship between master and slave outputs may be specified.

The most practical use of synchronisation will be to provide outputs at the same frequency, or maybe harmonics, but with phase differences.

Connections for Synchronisation

The clock connection arrangement is for the rear panel 10MHz REF OUT of the master (which will be set to **master**) to be connected directly to the 10MHz REF IN socket of the slave (which will be set to **slave**).

Similarly the synchronising connection is from the SYNC OUT of the master to the TRIG IN input of the slave.

It is also possible for the master instrument to have its 10MHz REF IN driven from a frequency reference during synchronisation.

Generator Set-ups

Each generator can have its main parameters set to any value and each generator can be set to any waveform, except noise.

The master is set as follows.

Press **UTILITY-System-Refclk-LokTyp** to show the screen below.

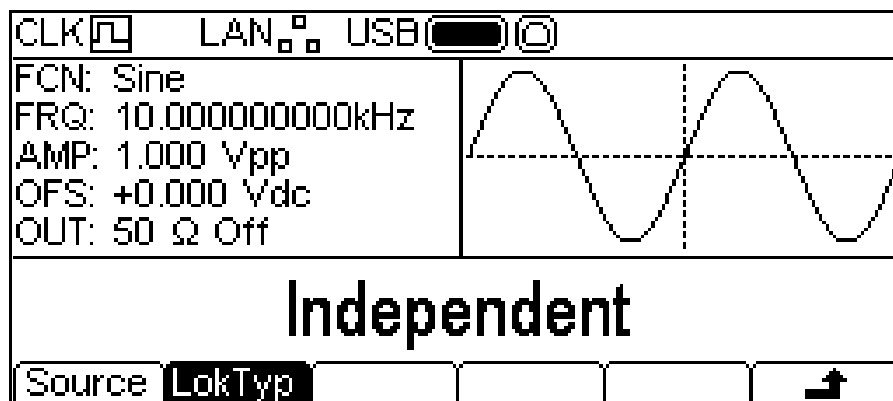

Press the **LokTyp** soft-key repeatedly until the Edit Box shows **Master**. The signal at the MAIN OUT from the generator will stop at the dc offset level.

To set the slave press **UTILITY-System-Refclk-LokTyp** but this time select **slave**. The slave instrument will sound a beep and will switch to using the external clock from the master, as shown by **CLK** (with a square icon) in the Status Line. The signal at the MAIN OUT from the generator will stop at the dc offset level.

Press the **Reset** soft-key on the slave followed by the **Lock** soft-key on the master. The generators will now both output their waveforms, which will be synchronised at a phase of 0° .

The phase relationship between the slave and the master is set from the **UTILITY-System-Refclk** menu. The phase may be changed in either of the ways detailed in General: Numeric Editing.

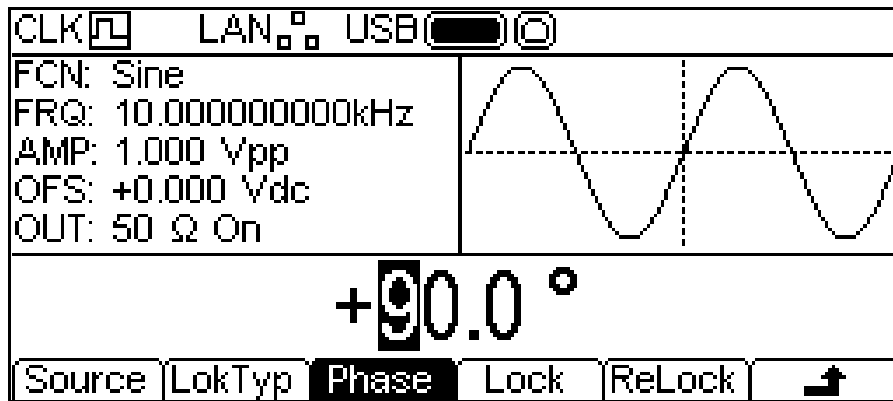

The convention adopted for the phase relationship between generators is that a positive phase setting advances the slave generator with respect to the master and a negative setting delays the slave generator. Phase changes on either generator will not cause a loss of synchronisation.

Hardware delays become increasingly significant as the frequency increases, causing additional phase delay between the master and slave. However, these delays can be largely nulled-out by 'backing-off' the phase settings of the slave.

Resynchronising

If the frequency value of either the master or the slave are changed it will be necessary to resynchronise the generators. This may be done from the **UTILITY-System-Refclk** menu of the master by pressing the **ReLock** soft-key. However, with master selected the **ReLock** soft-key also appears in the top level carrier wave menu as shown below.

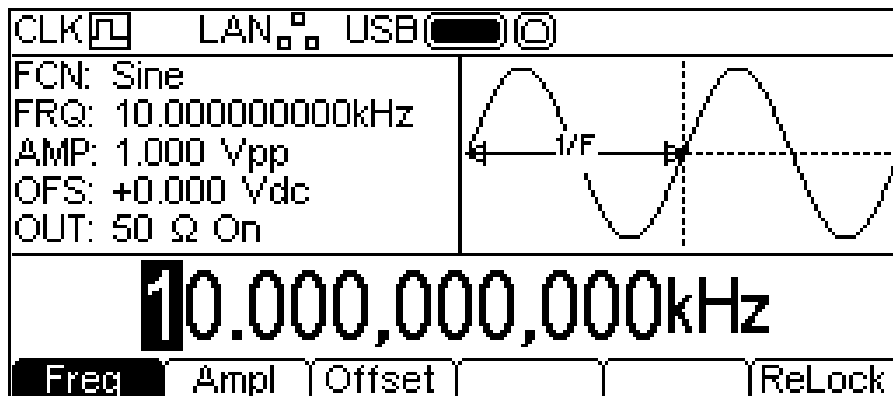

The generators may be resynchronised at any time by pressing either of the **ReLock** soft-keys.

Calibration

All parameters can be calibrated without opening the case, i.e. the generator offers 'closed-box' calibration. All adjustments are made digitally with calibration constants stored in flash memory. The calibration routine requires only a DVM, oscilloscope and a frequency counter and takes no more than a few minutes.

Calibration should be carried out only after the generator has been operating for at least 30 minutes in normal ambient conditions.

Equipment Required

- 3½ digit DVM with 0.25% DC accuracy and 0.5% AC accuracy at 1kHz.
- Universal counter capable of measuring 10.00000MHz with an accuracy of ±0.1ppm.
- Oscilloscope with a bandwidth of at least 100MHz.

Calibration Procedure

Pressing the UTILITY key followed by the **Calib** soft-key shows the opening screen for instrument calibration.

CLK <input type="checkbox"/>	LAN <input type="checkbox"/>	USB <input type="checkbox"/>		
Calibration selected. Are you sure? Yes - Press Cont'n. No - Press Done.	To calibrate you need 3.5 digit DVM, frequency counter and oscilloscope.			
Cont'n	Tests	Pswrd		Done

The software provides for a 4-digit password in the range 0000 to 9999 to be used to access the calibration procedure. If the password is left at the factory default of 0000 no messages are shown and calibration can proceed as described in the Calibration Routine section; only if a non-zero password has been set will the user be prompted to enter the password.

Setting the Password

On opening the Calibration screen press the **Pswrd** soft-key to show the password screen:

New Password					
					<input type="text"/>

Enter a 4-digit password from the keyboard; the Edit Box will show the message Confirm. Re-enter the password and the message **NEW PASSWORD STORED** will pop up for two seconds before returning to the top level calibration menu.

Using the Password to Access Calibration or Change the Password

With the password set, pressing **calib** on the utility screen will now show:

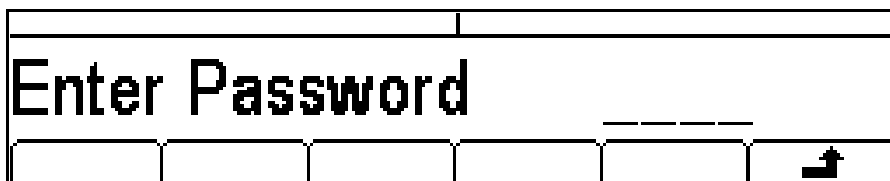

When the correct password has been entered from the keyboard the display changes to the opening screen of the calibration routine and calibration can proceed as described in the Calibration Routine section. If an incorrect password is entered the message **Incorrect Password Please Try Again** will pop up for two seconds before the display reverts to the Utility menu.

With the opening screen of the calibration routine displayed after correctly entering the password, the password can be changed by pressing **Pswrd** soft-key and following the procedure described in Setting the Password. If the password is set to 0000 again, password protection is removed.

The password is held in flash memory and will not be lost when the memory battery back-up is lost. In the event of the password being forgotten, contact the manufacturer for help in resetting the instrument.

Calibration Routine

The calibration procedure proper is entered by pressing **Cont'n** on the top level Calibration menu; pressing **Done** returns the display to the Utility menu. Pressing **Tests** calls a menu of basic hardware checks used at production test; these are largely self-explanatory but details can be found in the Service Manual if required.

At each calibration step the display changes to prompt the user to adjust the KNOB or cursor keys, until the reading on the specified instrument is at the value given. The cursor keys provide coarse adjustment, and the KNOB fine adjustment. Pressing **➡** increments the procedure to the next step; pressing **⬅** decrements back to the previous step. Alternatively, pressing **Cancel** returns the display to the final calibration screen at which the user can choose to either **Save**, **recall** or **Restart**.

Each calibration step allows a calibration value to be calibrated. The screen messages specify the instrument to use for measurement, the connector to connect it to, the value to adjust for and the method of adjustment

The full procedure is as follows:

STEP 1	DC offset zero.	Adjust for 0V ± 3mV
STEP 2	DC offset at + full scale.	Adjust for + 10V ± 10mV
STEP 3	DC offset at – full scale.	Check for –10V ± 50mV
STEP 4	Multiplier zero.	Adjust for minimum Volts AC
STEP 5	Multiplier offset.	Adjust for 0V ± 3mV
STEP 6	Waveform offset Filter 1.	Adjust for 0V ± 3mV
STEP 7	Output level at full-scale Filter 1	Adjust for 10V ± 10mV
STEP 8	Waveform offset Filter 2	Adjust for 0V ± 3mV
STEP 9	Output level at full-scale Filter 2	Adjust for 10V ± 10mV
STEP 10	20dB attenuator (A)	Adjust for 1V ± 1mV
STEP 11	20dB attenuator (B)	Adjust for 1V ± 1mV
STEP 12	10dB attenuator	Adjust for 3.162V ± 3mV

STEP 13	Sine amplitude flatness	Note reading
STEP 14	Level 1 MHz	Adjust for same reading
STEP 15	Level 2MHz	Adjust for same reading
STEP 16	Level 5MHz	Adjust for same reading
STEP 17	Level 10MHz	Adjust for same reading
STEP 18	Level 15MHz	Adjust for same reading
STEP 19	Level 20MHz	Adjust for same reading
STEP 20	Level 25MHz	Adjust for same reading
STEP 21	Level 30MHz	Adjust for same reading
STEP 22	Level 35MHz	Adjust for same reading
STEP 23	Level 40MHz	Adjust for same reading
STEP 24	Level 43MHz	Adjust for same reading
STEP 25	Level 45MHz	Adjust for same reading
STEP 26	Level 47MHz	Adjust for same reading
STEP 27	Level 50MHz	Adjust for same reading
STEP 28	Square-wave high level	Adjust for $10V \pm 10mV$
STEP 29	Square-wave low level	Adjust for $-10V \pm 10mV$
STEP 30	Rise time (0)	Adjust for 50ns
STEP 31	Rise time (0)	Adjust for 100ns
STEP 32	Rise time (1)	Adjust for 100ns
STEP 33	Rise time (1)	Adjust for 2 μ s
STEP 34	Rise time (2)	Adjust for 2 μ s
STEP 35	Rise time (2)	Adjust for 40 μ s
STEP 36	Fall time (0)	Adjust for 50ns
STEP 37	Fall time (0)	Adjust for 100ns
STEP 38	Fall time (1)	Adjust for 100ns
STEP 39	Fall time (1)	Adjust for 2 μ s
STEP 40	Fall time (2)	Adjust for 2 μ s
STEP 41	Fall time (2)	Adjust for 40 μ s
STEP 42	Square-wave symmetry 50%	Adjust for $50\mu s \pm 0.1\mu s$
STEP 43	Square-wave symmetry 75%	Adjust for $75\mu s \pm 0.1\mu s$
STEP 44	Square-wave symmetry 25MHz	Adjust for $50\% \pm 1\%$
STEP 45	Square-wave symmetry 35MHz	Adjust for $50\% \pm 1\%$
STEP 46	Square-wave symmetry 43MHz	Adjust for $50\% \pm 1\%$
STEP 47	Square-wave symmetry 50MHz	Adjust for $50\% \pm 1\%$
STEP 48	MOD offset	Adjust for $5V \pm 50mV$
STEP 49	MOD full scale	Adjust for $8V \pm 50mV$
STEP 50	Ref clock calibration	Adjust for $10.00000 \text{ MHz} \pm 1\text{ppm}$

Remote Calibration

Calibration of the instrument may be performed over the LAN, USB or GPIB interface. To completely automate the process the multimeter, oscilloscope and universal counter will also need to be remote controlled and the controller will need to run a calibration program unique to this instrument.

The remote calibration commands allow a simplified version of manual calibration to be performed by issuing commands from the controller. The controller must send the CALADJ command repeatedly and read the dmm or frequency meter until the required result for the selected calibration step is achieved. The CALSTEP command is then issued to accept the new value and move to the next step.

While in remote calibration mode very little error checking is performed and it is the controllers responsibility to ensure that everything progresses in an orderly way. Only the following commands should be used during calibration.

WARNING: Using any other commands while in calibration mode may give unpredictable results and could cause the instrument to lock up, requiring the power to be cycled to regain control.

CALIBRATION <cpd>, [nr1] The calibration control command. <cpd> can be one of three sub-commands:-

START - Enter calibration mode; this command must be issued before any other calibration commands will be recognised.

SAVE - Finish calibration, save the new values and exit calibration mode.

ABORT - Finish calibration, do not save the new values and exit calibration mode.

[nr1] represents the 4-digit calibration password. The password is only required with CALIBRATION START and then only if a non-zero password has been set from the instrument's keyboard. The password will be ignored, and will give no errors, at all other times.

It is not possible to set or change the password using remote commands.

CALADJ <nr1> Adjust the selected calibration value by <nr1>. The value must be in the range -100 to +100. Once an adjustment has been completed and the new value is as required the CALSTEP command must be issued for the new value to be accepted.

CALSTEP Step to the next calibration point.

CALVAL? Returns the value from level calibration. Valid for steps 13 to 27 only otherwise returns -1

For general information on remote operation and remote command formats, refer to the following sections.

Remote Interface Operation

The instrument can be remotely controlled via its USB, LAN or GPIB (optional) interfaces.

USB remote control operates in a similar way to an RS232 interface but via the USB connector. Software supplied with the instrument sets up the controlling computer to treat the USB connection as a virtual COM port. Application software on the computer can then access the instrument via that COM port.

The LAN interface is designed to meet LXI (LAN eXtensions for Instrumentation) version 1.2; the instrument is Class C compliant. Remote control using the LAN interface is possible using the TCP/IP Sockets protocol. The instrument also contains a basic Web server which provides information on the instrument and allows it to be configured from a web browser. Simple command line control from the browser is also possible.

The instrument is supplied with USB and LAN as standard; GPIB is an option. All interfaces are live at initial power up but access to individual interfaces may be restricted using the menus on the front panel or the configuration options on the web pages. To control the restriction of interfaces from the front panel select Utility-I/O to show the screen below.

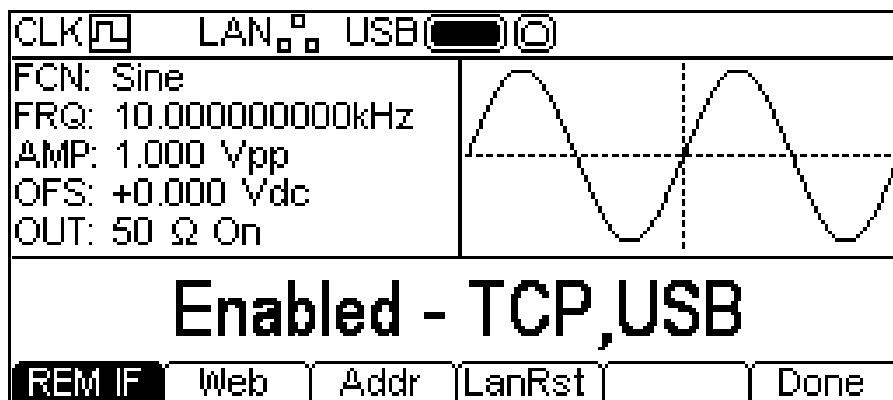

The default is for all available interfaces to be enabled as shown. The **REM IF** softkey may be used to select the interfaces required. Pressing the **REM IF** key will cycle round the possibilities, in this case **Enabled - TCP,USB**, **Enabled - TCP only** and **Enabled - USB Only**. TCP is used instead of LAN because the LAN itself is not disabled and could still be used to access the instrument web server, Disabling TCP does, however, disable the web page command line control of the instrument.

The web page access may also be disabled independently by pressing the **Web** soft-key. Alternate presses will produce **Enabled - WEBPAGE** and **Disabled - WEBPAGE**.

Address Selection

The instrument address capability is strictly required only by the GPIB interface. However, use can be made of the ADDRESS? command over any of the interfaces to easily identify which instrument is being controlled by a particular COM port (for USB) or TCP socket (for LAN). Note that the LAN interface also has a separate 'Identify' function, accessible from the instrument's web pages, that flashes the instrument's display until the function is cancelled.

The address is set from the instrument's front panel or web pages. To set the address from the front panel press the **Addr** soft-key on the Utility-I/O menu which will show the following.

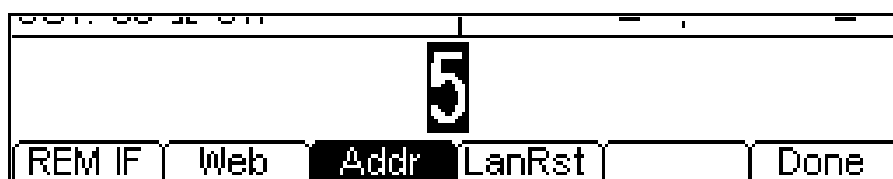

The address may be changed in either of the ways detailed in Numeric Editing Principles.

Remote/Local Operation

At power-on the instrument will be in the local state so the REM indicator is not displayed on the Status Line. In this state all front panel operations are possible. When the instrument receives a command from an interface the remote state will be entered and the REM indicator is displayed on Status Line. In this state the front panel is locked out and remote commands only will be processed. The instrument may be returned to the local state by pressing the LOCAL key; however, the effect of this action will only remain until the instrument receives another character from the interface, when the remote state will once again be entered. Returning to Local by this action will keep the settings at their last remotely set values.

USB Interface

The USB interface is a virtual COM port which can be controlled by a PC as if it was an RS232 device. The instrument is supplied with a CD containing an .inf file for the standard Microsoft drivers available in Windows 2000, XP, Vista and Windows 7; the installation wizard will install the driver (32-bit or 64-bit) appropriate to the PC's operating system. Any updates are available via the TTI website, www.tti-test.com.

Installation of the interface driver is achieved by connecting the instrument to a PC via a standard USB cable. The Windows' plug and play functions should automatically recognise the addition of new hardware attached to the USB interface and, if this is the first time the connection has been made, prompt for the location of a suitable driver. Provided that the standard Windows prompts are followed correctly Windows will install the appropriate driver and establish a virtual COM port within the PC. The number of the new COM port will depend upon the number of co-existing COM ports within the PC. The virtual COM port can be driven by Windows applications in exactly the same way as a standard COM port, except that the Baud rate setting of the virtual COM port is ignored.

The driver will remain installed on the PC so that the establishment of a virtual COM port is done automatically each time the instrument is connected to the PC via USB in the future.

Further virtual COM ports are created for each additional instrument connected to the PC via USB. Each instrument is assigned a separate virtual COM port when it is first connected and the same COM port will be assigned each time that instrument is subsequently connected; the PC software makes use of the unique code embedded in each instrument to link it to the same virtual COM port irrespective of which physical USB port it is connected to.

Use can also be made of the ADDRESS? command to easily identify which instrument is being controlled by a particular COM port. Although the addressing capability is ignored in USB operation the address can still be set and used as an identifier; set each USB-connected instrument to a different address and send the ADDRESS? command from each virtual COM port to confirm which instrument is connected to that port.

LAN Interface

The LAN interface is designed to comply with the LXI standard version 1.2 and contains the interfaces and protocols described below. Since it is possible to misconfigure the LAN interface, making it impossible to communicate with the instrument over LAN, a LAN Configuration Initialise (LCI) mechanism is provided via the menus from the front panel to reset the instrument's interfaces to the factory default. The default setting is for the instrument to attempt to obtain settings via DHCP if available or, if DHCP times out (30 seconds), via Auto-IP. In the very unlikely event that an Auto-IP address cannot be found a static IP address of 192.168.0.100 is assigned. Resetting the LAN removes any password protection which has been set on the web page.

To reset the LAN interface press the **LanRst** soft-key on the Utility-I/O menu.

For more information on LXI standards refer to www.lxistandard.org/home.

LAN Connection

To use the LAN interface, the IP address of the unit must be known. There is a LXI Discovery Tool on the supplied CD-ROM which can be used to display the IP addresses (and other associated information) of all connected devices that comply with the VXI-11 discovery protocol. This tool is a Windows PC application that should be installed and run on the controlling PC with the unit either connected directly to the PC network connector or via a router. Connecting via a router is recommended as this is significantly quicker to assign an IP address; connecting directly to the PC will begin to assign an IP address only after a 30 second DHCP time-out. Double clicking on any entry in the list of devices discovered will open the PC's web browser and display the Home page of that device.

There are also tools for LAN discovery included as part of the National Instruments Measurement and Automation Explorer package and the Agilent Vee application.

It is also possible to discover the assigned IP address from the Help menu by choosing option 3 and scrolling the screen down to the IP address.

Web Server; Configuration Password Protection

The unit contains a basic web server. This provides information on the instrument and allows it to be configured. The Configure page can be password protected to deter unauthorised changes to the remote operation configuration; the default configuration is 'no password'.

The Configure page itself explains how to set the password. The password can be up to 15 characters long. The password will, however, be reset to the default (no password) if the front panel is used to reset all the LAN parameters to their factory default.

The web pages also have an 'Identify' function which allows the user to send an identifying command to the instrument which causes its display to flash until the command is cancelled.

ICMP Ping Server

The unit contains an ICMP server allowing the instrument to be 'pinged' via either its host name or IP address.

VXI-11 Discovery Protocol

The instrument has very limited support of VXI-11 which is sufficient for the discovery protocol and no more.

The instrument implements a Sun RPC Port-mapper on TCP port 111 and UDP port 111 as defined in RPC1183. The calls supported are: NULL, GET PORT and DUMP.

On TCP port 1024 a very simple VXI-11 protocol is implemented sufficient only for instrument discovery. This implements the following calls: CREATE LINK, DEVICE_WRITE, DEVICE_READ and DESTROY_LINK.

Once a link has been created anything written to the device is ignored and any read from the device returns the identification string as would be expected from a "*IDN?" of the form

'Manufacturer, Model, Serial No., XX.xx – YY.yy' – ZZ.zz

where 'XX.xx' is the revision of the main firmware and 'YY.yy' is the revision of the remote interface firmware and 'ZZ.zz' is the revision of the USB flash drive firmware.

VISA Resource Name

Because of the limited support for VXI-11(Discovery Protocol only), the instrument must be referred to by its raw socket information when used in software packages which communicate via a VISA resource name. For example, an instrument at IP address 192.168.1.100 would normally have a VISA resource name of "TCPIP0::192.168.1.100::inst0::INSTR" but for this instrument the name must be modified to read "TCPIP0::192.168.1.100::9221::SOCKET" where 9221 is the TCP port used by this instrument for control and monitoring, see below.

XML Identification Document URL

As required by the LXI Standard, the instrument provides an XML identification document that can be queried via a GET at “http://<hostname>:80/lxi/identification” that conforms to the LXI XSD Schema (available at <http://www.lxistandard.org/InstrumentIdentification/1.0>) and the W3C XML Schema Standards (<http://www.w3.org/XML/Schema>). This document describes the instrument.

TCP Sockets

The instrument uses 1 socket on TCP port 9221 for instrument control and monitoring. Text commands are sent to this port as defined in ‘Remote Commands’ and any replies are returned via the same port.

LAN Status indication

The **LAN** field in the Status Line can show multiple status indications. When there is no LAN connection, for example no cable connected, the field will show **LAN**. While the system is attempting to connect the icon will flash. When successfully connected with remote control enabled the field will show **LAN**. If connected but remote control is disabled it will show **LAN**. Finally an unsuccessful attempt to connect will show **LAN**.

GPIB Interface

The GPIB interface 24-way connector is located on the instrument rear panel. The pin connections are as specified in IEEE Std. 488.1-1987 and the instrument complies with IEEE Std. 488.1-1987 and IEEE Std. 488.2-1987.

GPIB Subsets

This instrument contains the following IEEE 488.1 subsets:

Source Handshake	SH1
Acceptor Handshake	AH1
Talker	T6
Listener	L4
Service Request	SR1
Remote Local	RL2
Parallel Poll	PP1
Device Clear	DC1
Device Trigger	DT0
Controller	C0
Electrical Interface	E2

GPIB IEEE Std. 488.2 Error Handling – Query Error Register

The IEEE 488.2 UNTERMINATED error (addressed to talk with nothing to say) is handled as follows. If the instrument is addressed to talk and the response formatter is inactive and the input queue is empty then the UNTERMINATED error is generated. This will cause the Query Error bit to be set in the Standard Event Status Register, a value of 3 to be placed in the Query Error Register and the parser to be reset. See the Status Reporting section for further information.

The IEEE 488.2 INTERRUPTED error is handled as follows. If the response formatter is waiting to send a response message and a <PROGRAM MESSAGE TERMINATOR> has been read by the parser or the input queue contains more than one END message then the instrument has been INTERRUPTED and an error is generated. This will cause the Query Error bit to be set in the Standard Event Status Register, a value of 1 to be placed in the Query Error Register and the response formatter to be reset thus clearing the output queue. The parser will then start parsing the next <PROGRAM MESSAGE UNIT> from the input queue. See the Status Reporting section for further information.

The IEEE 488.2 DEADLOCK error is handled as follows. If the response formatter is waiting to send a response message and the input queue becomes full then the instrument enters the DEADLOCK state and an error is generated. This will cause the Query Error bit to be set in the Standard Event Status Register, a value of 2 to be placed in the Query Error Register and the response formatter to be reset thus clearing the output queue. The parser will then start parsing the next <PROGRAM MESSAGE UNIT> from the input queue. See the Status Reporting section for further information.

GPIB Parallel Poll

Complete parallel poll capabilities are offered on this instrument. The Parallel Poll Enable Register is set to specify which bits in the Status Byte Register are to be used to form the *ist* local message. The Parallel Poll Enable Register is set by the *PRE <nrf> command and read by the *PRE? command. The value in the Parallel Poll Enable Register is ANDed with the Status Byte Register; if the result is zero then the value of *ist* is 0 otherwise the value of *ist* is 1.

The instrument must also be configured so that the value of *ist* can be returned to the controller during a parallel poll operation. The instrument is configured by the controller sending a Parallel Poll Configure command (PPC) followed by a Parallel Poll Enable command (PPE). The bits in the PPE command are shown below:

bit 7 =	X	don't care
bit 6 =	1	Parallel poll enable
bit 5 =	1	
bit 4 =	0	
bit 3 =	Sense	sense of the response bit; 0 = low, 1 = high
bit 2 =	?	bit position of the response
bit 1 =	?	
bit 0 =	?	

Example. To return the RQS bit (bit 6 of the Status Byte Register) as a 1 when true and a 0 when false in bit position 1 in response to a parallel poll operation send the following commands

*PRE 64<pmt>, then PPC followed by 69H (PPE)

The parallel poll response from the instrument will then be 00H if RQS is 0 and 01H if RQS is 1.

During parallel poll response the DIO interface lines are resistively terminated (passive termination). This allows multiple devices to share the same response bit position in either wired-AND or wired-OR configuration, see IEEE 488.1 for more information.

Status Reporting

A separate error and status model is maintained for each interface instance; an interface instance is defined as a potential connection. USB and GPIB are inherently single connections so represent one interface instance each. LAN, however, allows for multiple simultaneous connections and therefore represents multiple interface instances. One interface instance is allocated to the TCP socket interface and one more is allocated to the Web page interface. Having a separate model for each interface instance ensures that data does not get lost as many commands e.g. '*ESR?' clear the contents on read.

Error status is maintained using a set of registers; these are described in the following paragraphs and shown on the Status Model at the end of this section.

Standard Event Status and Standard Event Status Enable Registers

These two registers are implemented as required by the IEEE Std. 488.2.

Any bits set in the Standard Event Status Register which correspond to bits set in the Standard Event Status Enable Register will cause the ESB bit to be set in the Status Byte Register.

The Standard Event Status Register is read and cleared by the *ESR? command. The Standard Event Status Enable register is set by the *ESE <nrf> command and read by the *ESE? command.

It is a bit field where each bit has the following significance.

- Bit 7: Power On. Set when power is first applied to the instrument.
- Bit 6: User Request (Not used).
- Bit 5: Command Error. Set when a syntax type error is detected in a command from the bus. The parser is reset and parsing continues at the next byte in the input stream
- Bit 4: Execution Error. Set when an error is encountered while attempting to execute a completely parsed command. The appropriate error number will be reported in the Execution Error Register, see Error Messages section
- Bit 3: Not used.
- Bit 2: Query Error. Set when a query occurs. The appropriate error number will be reported in the Query Error Register, see Query Error Register section.
- Bit 1: Not used.
- Bit 0: Operation Complete: Set in response to the '*OPC' command.

Execution Error Register

This register contains a number representing the last error encountered over the current interface. The Execution Error Register is read and cleared using the 'EER?' command. On power up this register is set to 0 for all interface instances.

Status Byte Register and Service Request Enable Register

These two registers are implemented as required by the IEEE STD. 488.2.

Any bits set in the Status Byte Register which correspond to bits set in the Service Request Enable Register will cause the RQS/MSS bit to be set in the Status Byte Register, thus generating a Service Request on the bus.

The Status Byte Register is read either by the *STB? command, which will return MSS in bit 6, or by a Serial Poll which will return RQS in bit 6. The Service Request Enable register is set by the *SRE <nrf> command and read by the *SRE? command.

- Bit 7 - Not used.
- Bit 6 - RQS/MSS. This bit, as defined by IEEE Std. 488.2, contains both the Requesting Service message and the Master Status Summary message. RQS is returned in response to a Serial Poll and MSS is returned in response to the *STB? command.
- Bit 5 - ESB. The Event Status Bit. This bit is set if any bits set in the Standard Event Status Register correspond to bits set in the Standard Event Status Enable Register.
- Bit 4 - MAV. The Message Available Bit. This will be set when the instrument has a response message formatted and ready to send to the controller. The bit will be cleared after the Response Message Terminator has been sent.
- Bit 3 - Not used.
- Bit 2 - Not used.
- Bit 1 - Not used
- Bit 0 - Not used

Status Model

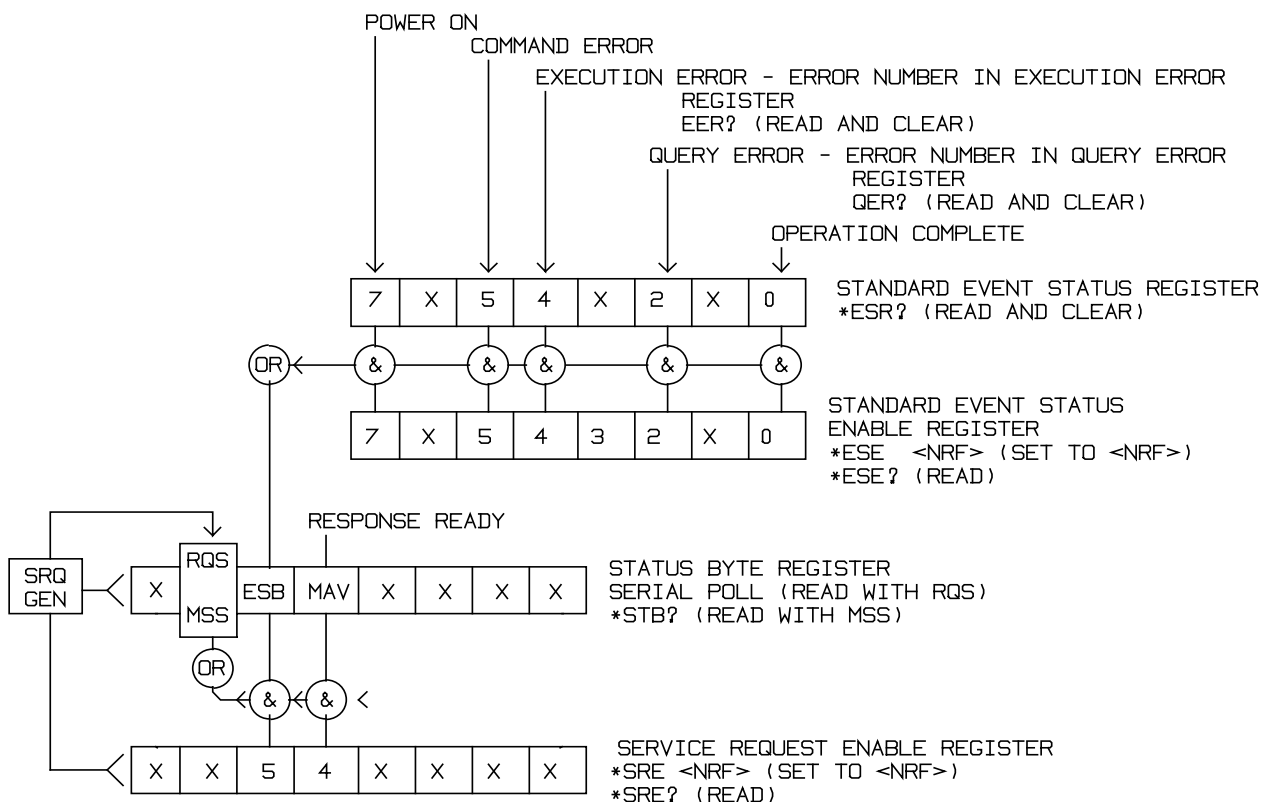

Power-on and Remote Operation Default Settings

The following instrument status values are set at power on:

Status Byte Register	= 0
Service Request Enable Register †	= 0
Standard Event Status Register	= 128 (pon bit set)
Standard Event Status Enable Register †	= 0
Execution Error Register	= 0
Query Error Register	= 0
Parallel Poll Enable Register †	= 0

† Registers marked thus are specific to the GPIB section of the instrument and are of limited use via other interfaces.

The instrument will be in local state with the front panel controls active.

The instrument parameters at power-on are always the same as at last switch off with the exception of the output status. By default the output is always off at power on but the user may change this from the front panel to be the same at power on as it was at switch off, see Power On State paragraph in the Utility Menus - System section.

The *RST (reset) interface command resets the instrument to the Remote Operation Default settings.

Remote Commands

USB/LAN Remote Command Format

USB input to the instrument is buffered in a 256 byte input queue which is filled, under interrupt, in a manner transparent to all other instrument operations. USB interface conforms with USB 2.0 Full Speed.

LAN input to the instrument is buffered in a 1500 byte input queue which is filled, under interrupt, in a manner transparent to all other instrument operations. LAN interface conforms with LXI (LAN eXtensions for Instrumentation) version 1.2.

Commands must be sent as specified in the commands list and must be terminated with the command terminator code 0AH (Line Feed, LF). Commands may be sent in groups with individual commands separated from each other by the code 3BH (;). The group must be terminated with command terminator 0AH (Line Feed, LF).

Responses from the instrument to the controller are sent as specified in the commands list. Each response is terminated by a <RESPONSE MESSAGE TERMINATOR> which is 0DH (Carriage Return, CR) followed by 0AH (Line Feed, LF).

<WHITE SPACE> is defined as character codes 00H to 20H inclusive.

<WHITE SPACE> is ignored except in command identifiers. e.g. '*C LS' is not equivalent to '*CLS'. The high bit of all characters is ignored. The commands are case insensitive.

GPIB Remote Command Formats

GPIB input to the instrument is buffered in a 256 byte input queue which is filled, under interrupt, in a manner transparent to all other instrument operations. The queue contains raw (un-parsed) data which is taken, by the parser, as required. Commands (and queries) are executed in order and the parser will not start a new command until any previous command or query is complete. There is no output queue which means that the response formatter will wait, indefinitely if necessary, until the instrument is addressed to talk and the complete response message has been sent, before the parser is allowed to start the next command in the input queue.

Commands are sent as <PROGRAM MESSAGES> by the controller, each message consisting of zero or more <PROGRAM MESSAGE UNIT> elements separated by <PROGRAM MESSAGE UNIT SEPARATOR> elements.

A <PROGRAM MESSAGE UNIT> is any of the commands in the remote commands list.

A <PROGRAM MESSAGE UNIT SEPARATOR> is the semi-colon character ';' (3BH).

<PROGRAM MESSAGES> are separated by <PROGRAM MESSAGE TERMINATOR> elements which may be any of the following:

NL	The new line character (0AH)
NL^END	The new line character with the END message
^END	The END message with the last character of the message

Responses from the instrument to the controller are sent as <RESPONSE MESSAGES>. A <RESPONSE MESSAGE> consists of one <RESPONSE MESSAGE UNIT> followed by a <RESPONSE MESSAGE TERMINATOR>.

A <RESPONSE MESSAGE TERMINATOR> is the new line character with the END message NL^END.

Each query produces a specific <RESPONSE MESSAGE> which is listed along with the command in the remote commands list.

<WHITE SPACE> is ignored except in command identifiers. e.g. '*C LS' is not equivalent to '*CLS'. <WHITE SPACE> is defined as character codes 00H to 20H inclusive with the exception of the NL character (0AH). The high bit of all characters is ignored. The commands are case insensitive.

Command List

This section lists all commands and queries implemented in this instrument.

Note that there are no dependent parameters, coupled parameters, overlapping commands, expression program data elements or compound command program headers; each command is completely executed before the next command is started. All commands are sequential and the operation complete message is generated immediately after execution in all cases.

The following nomenclature is used:

- <rmt> <RESPONSE MESSAGE TERMINATOR>
- <cpd> <CHARACTER PROGRAM DATA>, i.e. a short mnemonic or string such as ON or OFF.
- <nrf> A number in any format. e.g. 12, 12.00, 1.2 e1 and 120 e-1 are all accepted as the number 12. Any number, when received, is converted to the required precision consistent with the use then rounded to obtain the value of the command.
- <nr1> A number with no fractional part, i.e. an integer.
- [..] Any item(s) enclosed in these brackets are optional parameters. If more than one item is enclosed then all or none of the items are required.

The commands which begin with a * are implemented as specified by IEEE Std 488.2 as Common commands. All will function when used on the other interfaces but some may be of little use.

The Operation Complete bit (bit 0) in the Standard Event Status Register is only ever set by the *OPC command. The *OPC (or the *OPC?) command can be used for device synchronisation due to the sequential nature of remote operations.

Continuous Carrier Wave Commands

- | | |
|----------------|--|
| WAVE <cpd> | Set the output waveform type to <SINE>, <SQUARE>, <RAMP>, <TRIANG> <PULSE>, <NOISE> or <ARB>. |
| FREQ <nrf> | Set the waveform frequency to <nrf> Hz |
| PER <nrf> | Set the waveform period to <nrf> Sec |
| AMPLRNG <cpd> | Set the amplitude range to <AUTO> or <HOLD> |
| AMPUNIT <cpd> | Set the amplitude units to <VPP>, <VRMS> or <DBM>. |
| AMPL <nrf> | Set the amplitude to <nrf> in the units as specified by the AMPUNIT command. |
| HILVL <nrf> | Set the amplitude-high-level to <nrf> Volts |
| LOLVL <nrf> | Set the amplitude-low-level to <nrf> Volts |
| DCOFFS <nrf> | Set the dc offset to <nrf> Volts |
| OUTPUT <cpd> | Set the output to <ON>, <OFF>, <NORMAL> or <INVERT> |
| ZLOAD <cpd> | Set the output load, which the generator is to assume for amplitude and dc offset entries, to <1..10,000>Ohms or <OPEN>. |
| SQRSYMM <nrf> | Set the square waveform symmetry to <nrf> % |
| RMPSYMM <nrf> | Set the ramp waveform symmetry to <nrf> % |
| SYNCOUT <cpd> | Set the sync output to <ON>, <OFF> |
| SYNCTYPE <cpd> | Set the sync type to <AUTO>, <CARRIER>, <MODULATION>, <SWEEP>, <BURST> or <TRIGGER> |

Pulse Generator Commands

PULSFREQ <nrf>	Set the pulse waveform frequency to <nrf> Hz
PULSPER <nrf>	Set the pulse waveform period to <nrf> Sec
PULSWID <nrf>	Set the pulse waveform width to <nrf> Sec
PULSSYMM <nrf>	Set the pulse waveform symmetry to <nrf> %
PULSEEDGE <nrf>	Set the pulse waveform edges (positive and negative edge) to <nrf> micro Sec. Value zero sets to the minimum value allowed.
PULSRANGE <cpd>	Set the pulse rise and fall range to <1>, <2> or <3>. 1 sets the range from 5ns to 99.9ns 2 sets the range from 100ns to 1.999us 3 sets the range from 2us to 40us
PULSRISE <nrf>	Set the pulse waveform positive edge to <nrf> micro Sec
PULSFALL <nrf>	Set the pulse waveform negative edge to <nrf> micro Sec
PULSDLY <nrf>	Set the pulse waveform delay to <nrf> Sec

Noise Generator Commands

NOISADD <cpd>	Select <ON> to add the noise to the output waveform and <OFF> to remove the noise from the output waveform.
NOISLVL <nr1>	Set the output noise level to <nr1> %
WAVELVL <nr1>	Set the output waveform level to <nr1> %

Arbitrary Waveform Commands

ARBDCOFFS <nrf>	Set the arbitrary dc waveform offset to <nrf> Volts
ARBLOAD <cpd>	Set the output waveform type to <DC>, <SINC>, <EXPRISE>, <LOGRISE> <RAMPUP>, <RAMPDN>, <TRIANG>, <SQUARE>, <ARB1>, <ARB2>, <ARB3>, <ARB4>, <"USERNAME1">, <"USERNAME1">, <"USERNAME2">, <"USERNAME3"> or <"USERNAME4">.
ARBRESIZE <cpd>,<nr1>	Change the size of arbitrary waveform <cpd> to <nr1>.
ARBDEF <cpd1>,<cpd2>,<cpd3>	Define an arbitrary waveform with user specified waveform name and waveform point interpolation state, where. <cpd1> is ARB1, ARB2, ARB3 or ARB4 <cpd2> is "user specified waveform name" <cpd3> is waveform point interpolation ON or OFF
ARB1 <bin>	Load data to an existing arbitrary waveform memory location ARB1. The data consists of two bytes per point with no characters between bytes or points. The point data is sent high byte first. The data block has a header which consists of the # character followed by several ascii coded numeric characters. The first of these defines the number of ascii characters to follow and these following characters define the length of the binary data in bytes. The instrument will wait for data indefinitely If less data is sent. If more data is sent the extra is processed by the command parser which results in a command error.
ARB2 <bin>	See ARB1 description.
ARB3 <bin>	See ARB1 description.

ARB4 <bin>	See ARB1 description.
ARB1DEF?	Returns user specified waveform name, waveform point interpolation state and waveform length of ARB1.
ARB2DEF?	See ARB1DEF? description.
ARB3DEF?	See ARB1DEF? description.
ARB4DEF?	See ARB1DEF? description.
ARB1?	Returns the data from an existing arbitrary waveform location ARB1. The data consists of two bytes per point with no characters between bytes or points. The point data is sent high byte first. The data block has a header which consists of the # character followed by several ascii coded numeric characters. The first of these defines the number of ascii characters to follow and these following characters define the length of the binary data in bytes.
ARB2?	See ARB1? description.
ARB3?	See ARB1? description.
ARB4?	See ARB1? description.

Modulation Commands

MOD <cpd>	Set modulation to <OFF>, <AM>, <FM>, <PM>, <FSK> or <PWM>
MODAMSHAPE <cpd>	Set AM waveform shape to <SINE>, <SQUARE>, <RAMPUP>, <RAMPDN>, <TRIANG>, <NOISE>, <DC>, <SINC>, <EXPRISE>, <LOGRISE>, <ARB1>, <ARB2>, <ARB3> or <ARB4>
MODFM SHAPE <cpd>	Set FM waveform shape to <SINE>, <SQUARE>, <RAMPUP>, <RAMPDN>, <TRIANG>, <NOISE>, <DC>, <SINC>, <EXPRISE>, <LOGRISE>, <ARB1>, <ARB2>, <ARB3> or <ARB4>
MODPM SHAPE <cpd>	Set PM waveform shape to <SINE>, <SQUARE>, <RAMPUP>, <RAMPDN>, <TRIANG>, <NOISE>, <DC>, <SINC>, <EXPRISE>, <LOGRISE>, <ARB1>, <ARB2>, <ARB3> or <ARB4>
MODPWM SHAPE <cpd>	Set PWM waveform shape to <SINE>, <SQUARE>, <RAMPUP>, <RAMPDN>, <TRIANG>, <NOISE>, <DC>, <SINC>, <EXPRISE>, <LOGRISE>, <ARB1>, <ARB2>, <ARB3> or <ARB4>
MODAM SRC <cpd>	Set AM waveform source to <INT> or <EXT>
MODFM SRC <cpd>	Set FM waveform source to <INT> or <EXT>
MODPM SRC <cpd>	Set PM waveform source to <INT> or <EXT>
MODPWM SRC <cpd>	Set PWM waveform source to <INT> or <EXT>
MODAM FREQ <nrf>	Set AM waveform frequency to <nrf> Hz
MODFM FREQ <nrf>	Set FM waveform frequency to <nrf> Hz
MODPM FREQ <nrf>	Set PM waveform frequency to <nrf> Hz
MODPWM FREQ <nrf>	Set PWM waveform frequency to <nrf> Hz
MODAM DEPTH <nrf>	Set AM waveform depth to <nrf> %
MODFM DEV <nrf>	Set FM waveform deviation to <nrf> Hz
MODPM DEV <nrf>	Set PM waveform deviation to <nrf> degree
MODPWM DEV WDT <nrf>	Set PWM waveform deviation to <nrf> sec
MODPWM DEV SYM <nrf>	Set PWM waveform deviation to <nrf> %

MODFSKSRC <cpd>	Set FSK waveform source to <INT> or <EXT>
MODHOPFREQ <nrf>	Set HOP frequency to <nrf> Hz
MODFSKRATE <nrf>	Set FSK rate to <nrf> Hz
MODPOLFSK <cpd>	Set FSK slope to <POS> or <NEG>

Sweep Commands

SWPTYPE <cpd>	Set the sweep type to <LINUP>, <LINDN>, <LINUPDN>, <LINDNUP>, <LOGUP>, <LOGDN>, <LOGUPDN> or <LOGDNUP>
SWPMODE <cpd>	Set the sweep mode to <CONT> or <TRIG>.
SWPTRGSRC <cpd>	Set the sweep trigger source to <INT>, <EXT> or <MAN>.
SWPTRGPER <nrf>	Set the sweep trigger period to <nrf> sec.
SWPTRGPOL <cpd>	Set the sweep trigger slope to <POS> or <NEG>.
SWPBEGFREQ <nrf>	Set the sweep start frequency to <nrf> Hz.
SWPENDFREQ <nrf>	Set the sweep stop frequency to <nrf> Hz.
SWPCNTFREQ <nrf>	Set the sweep centre frequency to <nrf> Hz.
SWSPNFREQ <nrf>	Set the sweep frequency span to <nrf> Hz.
SWPMKR <cpd>	Set the sweep marker to <ON> or <OFF>.
SWPMKRFREQ <nrf>	Set the sweep marker to <nrf> Hz.
SWPTIME <nrf>	Set the sweep time to <nrf> sec.
SWP <cpd>	Set the sweep to <ON> or <OFF>.

Burst Commands

BSTTRGSRC <cpd>	Set the burst trigger source to <INT>, <EXT> or <MAN>.
BSTPER <nrf>	Set the burst trigger period to <nrf> sec.
BSTTRGPOL <cpd>	Set the burst trigger slope to <POS> or <NEG>.
BSTCOUNT <nr1>	Set the burst count to <nr1> cycles, maximum 1048575 cycles.
BSTPHASE <nrf>	Set the burst phase to <nrf> degree.
BST <cpd>	Set the burst to <OFF>, <NCYC>, <GATED> or <INFINITE>.

Clock and Synchronising Commands

CLKSRC <cpd>	Set the clock source to <INT> or <EXT>.
CLKSRC?	Returns the clock source <INT> or <EXT>.
LOCKMODE <cpd>	Set the synchronising mode to <MASTER>, <SLAVE> or <INDEP>.
SLVRST	Set the SLAVE generator ready to be synchronised.
MSTLOCK	Send signal to SLAVE generator to get synchronised.
MSTRELOCK	Resynchronise the two generators in MASTER-SLAVE mode.

System and Status Commands

*CLS	Clear Status. Clears the Status structure. This indirectly clears the Status Byte Register.
*ESE <nrf>	Set the Standard Event Status Enable Register to the value of <nrf>
*ESE?	Returns the value in the Standard Event Status Enable Register in <nr1> numeric format. The syntax of the response is <nr1><rmt>
*ESR?	Returns the value in the Standard Event Status Register in <nr1> numeric format. The register is then cleared. The response is <nr1><rmt>. See Status Reporting section for details.

*IST?	Returns ist local message as defined by IEEE Std. 488.2. The syntax of the response is 0<rmt>, if the local message is false, or 1<rmt>, if the local message is true.
*OPC	Sets the Operation Complete bit (bit 0) in the Standard Event Status Register. This will happen immediately the command is executed because of the sequential nature of all operations.
*OPC?	Query Operation Complete status. The response is always 1<rmt> and will be available immediately the command is executed because all commands are sequential.
*PRE <nrf>	Set the Parallel Poll Enable Register to the value <nrf>.
*PRE?	Returns the value in the Parallel Poll Enable Register in <nr1> numeric format. The syntax of the response is <nr1><rmt>
*SRE <nrf>	Set the Service Request Enable Register to <nrf>.
*SRE?	Returns the value of the Service Request Enable Register in <nr1> numeric format. The syntax of the response is <nr1><rmt>
*STB?	Returns the value of the Status Byte Register in <nr1> numeric format. The syntax of the response is <nr1><rmt>
*WAI	Wait for Operation Complete true. As all commands are fully executed before the next is started this command takes no additional action.
*TST?	The PSU has no self test capability and the response is always 0 <rmt>
EER?	Query and clear Execution Error Register. The response format is nr1<rmt>.
QER?	Query and clear Query Error Register. The response format is nr1<rmt>
*LRN?	Returns the complete setup of the instrument as a binary data block. To re-install the setup the block should be returned to the instrument exactly as it is received. The syntax of the response is LRN <bin>. The settings in the instrument are not affected by execution of the *LRN? Command.
LRN <bin>	Install data from a previous *LRN? command.
*RST	Resets the instrument parameters to their default values.
*RCL <nr1>	Recalls a previously stored instrument set-up file from the specified non-volatile memory location.
*SAV <nr1>	Saves the complete instrument set-up file to the specified non-volatile memory location.
*TRG	This command is the same as pressing the MAN/SYNC key. Its effect will depend on the context in which it is asserted.
*IDN?	Returns the instrument identification. The exact response is determined by the instrument configuration and is of the form of <Manufacturer, Model, Serial No., XX.xx – YY.yy’ – ZZ.zz> where ‘XX.xx’ is the revision of the main firmware and ‘YY.yy’ is the revision of the remote interface firmware and ‘ZZ.zz’ is the revision of the USB flash drive firmware
ADDRESS?	Returns the bus address of the instrument; This is the address used by GPIB, if fitted, or may be used as a general identifier over the other interfaces. The response format is <nr1><rmt>.
BEEPMODE <cpd>	Set beep mode to <ON>, <OFF>, <WARN>, or <ERROR>.
BEEP	Sound one beep.
LOCAL	Returns the instrument to local operation and unlocks the keyboard.

Calibration Specific Commands

See the calibration section for details of calibration specific commands.

Error Messages

Each error message has a number; only this number is reported via the remote control interfaces. Error message numbers are placed in the Execution Error Register where they can be read via the remote interfaces.

Remote Commands Summary

*CLS	clears status byte register of the interface
*ESE <nrf>	sets the standard event status enable register to the value of <nrf>
*ESE?	returns the value in the standard event status enable register in <nr1>
*ESR?	returns the value in the standard event status register in <nr1>
*IDN?	returns the instrument identification
*IST?	returns IST local message as defined by IEEE Std. 488.2
*LRN?	returns the complete setup of the instrument as a binary data block
*OPC	sets the Operation Complete bit (bit 0) in the standard event status register
*OPC?	returns always 1 to indicate the completion of sequential execution of commands
*PRE <nrf>	sets the parallel poll enable register to the value <nrf>
*PRE?	returns the value in the parallel poll enable register in <nr1> numeric format
*RCL <nrf>	recalls the instrument setup contained in store <nrf>
*RST	resets the instrument parameters to their default values
*SAV <nrf>	saves the complete instrument setup to the setup-file named <nrf>
*SRE <nrf>	sets the service request enable register to <nrf>
*SRE?	returns the value of the service request enable register in <nr1> numeric format
*STB?	returns the value of the status byte register in <nr1> numeric format
*TRG	this command is the same as pressing the TRIGGER key
*TST?	the generator has no self-test capability and the response is always 0<rmt>
*WAI	waits for operation complete and executed before the next is started
ADDRESS?	returns the instruments address
AMPL <nrf>	sets the amplitude to <nrf> in the units as specified by the AMPUNIT command
AMPLRNG <cpd>	sets the amplitude range to <AUTO> or <HOLD>
AMPUNIT <cpd>	sets the amplitude units to <VPP>, <VRMS> or <DBM>
ARB1 <bin>	loads the binary-data to an existing arbitrary waveform memory location ARB1
ARB2 <bin>	loads the binary-data to an existing arbitrary waveform memory location ARB2
ARB3 <bin>	loads the binary-data to an existing arbitrary waveform memory location ARB3
ARB4 <bin>	loads the binary-data to an existing arbitrary waveform memory location ARB1
ARB1?	returns the binary-data from an existing arbitrary waveform memory location ARB1
ARB2?	returns the binary-data from an existing arbitrary waveform memory location ARB2
ARB3?	returns the binary-data from an existing arbitrary waveform memory location ARB3
ARB4?	returns the binary-data from an existing arbitrary waveform memory location ARB4
ARB1DEF?	returns user specified waveform name, waveform point interpolation state and waveform length of ARB1
ARB2DEF?	returns user specified waveform name, waveform point interpolation state and waveform length of ARB2
ARB3DEF?	returns user specified waveform name, waveform point interpolation state and waveform length of ARB3

ARB4DEF?	returns user specified waveform name, waveform point interpolation state and waveform length of ARB4
ARBDCOFFS <nrf>	sets the arbitrary dc waveform offset to <nrf> Volts
ARBDEF <cpd1>,<cpd2>,<cpd3>	sets user specified waveform name <cpd2> and waveform point interpolation state <cpd3> of arbitrary waveform memory location <cpd1>
ARBLOAD	<cpd> sets the output waveform type to <DC>, <SINC>, <EXPRISE>, <LOGRISE> <RAMPUP>, <RAMPDN>, <TRIANG>, <SQUARE>, <ARB1>, <ARB2>, <ARB3>, <ARB4>, <"USRNAME1">, <"USERNAME2">, <"USERNAME3"> or <"USERNAME4">
ARBRESIZE <cpd>,<nrf>	changes the size of arbitrary waveform <cpd> to <nrf>
BEEP	sounds one beep
BEEPMODE <cpd>	sets beep mode to <ON>, <OFF>, <WARN>, or <ERROR>
BST <cpd>	sets the burst to <OFF>, <NCYC>, <GATED> or <INFINITE>
BSTCOUNT <nrf>	sets the burst count to <nrf> cycles, maximum 1048575 cycles
BSTPER <nrf>	sets the burst trigger period to <nrf> sec
BSTPHASE <nrf>	sets the burst phase to <nrf> degree
BSTTRGPOL <cpd>	sets the burst trigger slope to <POS> or <NEG>
BSTTRGSRC <cpd>	sets the burst trigger source to <INT>, <EXT> or <MAN>
CALADJ <nrf>	adjust the selected calibration value by <nrf>
CALIBRATION <cpd>,<nrf>	sets the calibration mode to <START>, <SAVE> or <ABORT>. <nrf> represents the calibration password
CALSTEP	step to the next calibration point
CALVAL?	returns the value from level calibration steps
CLKSRC <cpd>	sets the clock source to <INT> or <EXT>.
CLKSRC?	returns the clock source <INT> or <EXT>.
DCOFFS <nrf>	sets the dc offset to <nrf> Volts
EER?	query and clear execution error number register
FREQ <nrf>	sets the waveform frequency to <nrf> Hz
HILVL <nrf>	sets the amplitude-high-level to <nrf> Volts
LOCAL	returns the instrument to local operation and unlocks the keyboard
LOCKMODE <cpd>	sets the synchronising mode to <MASTER>, <SLAVE> or <INDEP>
LOLVL <nrf>	sets the amplitude-low-level to <nrf> Volts
LRN	install data from a previous *LRN? command.
MOD <cpd>	sets modulation to <OFF>, <AM>, <FM>, <PM>, <FSK> or <PWM>
MODAMDEPTH <nrf>	sets AM waveform depth to <nrf> %
MODAMFREQ <nrf>	sets AM waveform frequency to <nrf> Hz
MODAMSHAPE <cpd>	sets AM waveform shape to <SINE>, <SQUARE>, <RAMPUP>, <RAMPDN>, <TRIANG>, <NOISE>, <DC>, <SINC>, <EXPRISE>, <LOGRISE>, <ARB1>, <ARB2>, <ARB3> or <ARB4>
MODAMSRC <cpd>	sets AM waveform source to <INT> or <EXT>
MODFMDEV <nrf>	sets FM waveform deviation to <nrf> Hz

MODFMFREQ <nrf>	sets FM waveform frequency to <nrf> Hz
MODFM SHAPE <cpd>	sets FM waveform shape to <SINE>, <SQUARE>, <RAMPUP>, <RAMPDN>, <TRIANG>, <NOISE>, <DC>, <SINC>, <EXPRISE>, <LOGRISE>, <ARB1>, <ARB2>, <ARB3> or <ARB4>
MODFMSRC <cpd>	sets FM waveform source to <INT> or <EXT>
MODFSKRATE <nrf>	sets FSK rate to <nrf> Hz
MODFSK SRC <cpd>	sets FSK waveform source to <INT> or <EXT>
MODHOPFREQ <nrf>	sets HOP frequency to <nrf> Hz
MODPMDEV <nrf>	sets PM waveform deviation to <nrf> degree
MODPMFREQ <nrf>	sets PM waveform frequency to <nrf> Hz
MODPM SHAPE <cpd>	sets PM waveform shape to <SINE>, <SQUARE>, <RAMPUP>, <RAMPDN>, <TRIANG>, <NOISE>, <DC>, <SINC>, <EXPRISE>, <LOGRISE>, <ARB1>, <ARB2>, <ARB3> or <ARB4>
MODPMSRC <cpd>	sets PM waveform source to <INT> or <EXT>
MODPOLFSK <cpd>	sets FSK slope to <POS> or <NEG>
MODPWMDEVSYM <nrf>	sets PWM waveform deviation to <nrf> %
MODPWMDEVWDT <nrf>	sets PWM waveform deviation to <nrf> sec
MODPWMFREQ <nrf>	sets PWM waveform frequency to <nrf> Hz
MODPWM SHAPE <cpd>	sets PWM waveform shape to <SINE>, <SQUARE>, <RAMPUP>, <RAMPDN>, <TRIANG>, <NOISE>, <DC>, <SINC>, <EXPRISE>, <LOGRISE>, <ARB1>, <ARB2>, <ARB3> or <ARB4>
MODPWMSRC <cpd>	sets PWM waveform source to <INT> or <EXT>
MSTLOCK	sends signal to SLAVE generator to get synchronised
MSTRELOCK	resynchronises the two generators in MASTER-SLAVE mode
NOISADD <cpd>	select <ON> to add the noise to the output waveform and <OFF> to remove the noise from the output waveform
NOISLVL <nrf>	sets the output noise level to <nr1> %
OUTPUT <cpd>	sets the output to <ON>, <OFF>, <NORMAL> or <INVERT>
PER <nrf>	sets the waveform period to <nrf> Sec
PULSDLY <nrf>	sets the pulse waveform delay to <nrf> Sec
PULSEEDGE <nrf>	sets the pulse waveform edges (positive and negative edge) to <nrf> micro Sec. Value zero sets to the minimum value allowed
PULSFALL <nrf>	sets the pulse waveform negative edge to <nrf> micro Sec
PULSFREQ <nrf>	sets the pulse waveform frequency to <nrf> Hz
PULSPER <nrf>	sets the pulse waveform period to <nrf> Sec
PULSRANGE <cpd>	sets the pulse rise and fall range to <1>, <2> or <3>.
PULSRISE <nrf>	sets the pulse waveform positive edge to <nrf> micro Sec
PULSSYMM <nrf>	sets the pulse waveform symmetry to <nrf> %
PULSWID <nrf>	sets the pulse waveform width to <nrf> Sec
QER?	query and clear query error register

RMPSYMM <nrf>	sets the ramp waveform symmetry to <nrf> %
SQRSYMM <nrf>	sets the square waveform symmetry to <nrf> %
SLVRST	sets the SLAVE generator ready to be synchronised
SWP <cpd>	sets the sweep to <ON> or <OFF>
SWPBEGFREQ <nrf>	sets the sweep start frequency to <nrf> Hz
SWPCNTFREQ <nrf>	sets the sweep centre frequency to <nrf> Hz
SWPENDFREQ <nrf>	sets the sweep stop frequency to <nrf> Hz
SWPMKR <cpd>	sets the sweep marker to <ON> or <OFF>
SWPMKRFREQ <nrf>	sets the sweep marker to <nrf> Hz
SWPMODE <cpd>	sets the sweep mode to <CONT> or <TRIG>
SWPSPNFREQ <nrf>	sets the sweep frequency span to <nrf> Hz
SWPTIME <nrf>	sets the sweep time to <nrf> sec
SWPTRGPER <nrf>	sets the sweep trigger period to <nrf> sec
SWPTRGPOL <cpd>	sets the sweep trigger slope to <POS> or <NEG>
SWPTRGSRC <cpd>	sets the sweep trigger source to <INT>, <EXT> or <MAN>
SWPTYPE <cpd>	sets the sweep type to <LINUP>, <LINDN>, <LINUPDN>, <LINDNUP>, <LOGUP>, <LOGDN>, <LOGUPDN> or <LOGDNUP>
SYNCOUT <cpd>	sets the sync output to <ON>, <OFF>
SYNCTYPE <cpd>	sets the sync type to <AUTO>, <CARRIER>, <MODULATION>, <SWEEP>, <BURST> or <TRIGGER>
WAVE <cpd>	sets the output waveform type to <SINE>, <SQUARE>, <RAMP>, <TRIANG>, <PULSE>, <NOISE> or <ARB>
WAVELVL <nrf>	sets the output waveform level to <nr1> %
ZLOAD <cpd>	sets the output load, which the generator is to assume for amplitude and dc offset entries, to <1..10,000> or <OPEN>

Appendix 1. Information, Warning and Error Messages

In the following list where [VALUE] appears a numeric value will be inserted in the message which is appropriate for the parameter currently being edited. Message numbers that are omitted are reserved and not currently used. Some numbers can produce two different messages depending on the current instrument editing mode, these are indicated by 'or' in the list.

Error Messages

- 1 Firmware Update / Battery Fail. Initialised to factory default state.
- 2 Frequency invalid. Upper limit [VALUE].
 or Period invalid. Lower limit [VALUE].
- 4 Frequency invalid. Lower limit [VALUE].
 or Period invalid. Upper limit [VALUE].
- 6 Frequency invalid. Limited by Square duty cycle.
 or Period invalid. Limited by Square duty cycle.
- 8 Frequency invalid. Frequency cannot be less than deviation.
 or Period invalid. Frequency cannot be less than deviation.
- 10 Frequency invalid. Freq+Dev upper limit [VALUE].
 or Period invalid. Freq+Dev upper limit [VALUE].
- 12 Carrier frequency cannot be edited when Sweep is on.
 or Carrier period cannot be edited when Sweep is on.
- 14 Frequency invalid. Cannot exceed 10MHz for Finite Burst.
 or Period invalid. Cannot be less than 100ns for Finite Burst.
- 16 Frequency invalid. Cannot exceed 10MHz for Gated Burst.
 or Period invalid. Cannot be less than 100ns for Gated Burst.
- 20 Amplitude invalid. Upper limit [VALUE].
- 21 Amplitude invalid. 0dB Range Hold. Upper limit [VALUE].
- 22 Amplitude invalid. 10dB Range Hold. Upper limit [VALUE].
- 23 Amplitude invalid. 20dB Range Hold. Upper limit [VALUE].
- 24 Amplitude invalid. 30dB Range Hold. Upper limit [VALUE].
- 25 Amplitude invalid. 40dB Range Hold. Upper limit [VALUE].
- 26 Amplitude invalid. 50dB Range Hold. Upper limit [VALUE].
- 27 Amplitude invalid. Lower limit [VALUE].
- 28 Amplitude invalid. 0dB Range Hold. Lower limit [VALUE].
- 29 Amplitude invalid. 10dB Range Hold. Lower limit [VALUE].
- 30 Amplitude invalid. 20dB Range Hold. Lower limit [VALUE].
- 31 Amplitude invalid. 30dB Range Hold. Lower limit [VALUE].
- 32 Amplitude invalid. 40dB Range Hold. Lower limit [VALUE].
- 33 Amplitude invalid. 50dB Range Hold. Lower limit [VALUE].

-
- 34 Offset invalid. Upper limit [VALUE].
 - 35 Offset invalid. Lower limit [VALUE].
 - 36 Arb DC Offset invalid. Upper limit [VALUE].
 - 37 Arb DC Offset invalid. Lower limit [VALUE].
 - 38 High level invalid. Upper limit [VALUE].
 - 40 High level invalid. 0dB Range Hold. Upper limit [VALUE].
 - 41 High level invalid. 10dB Range Hold. Upper limit [VALUE].
 - 42 High level invalid. 20dB Range Hold. Upper limit [VALUE].
 - 43 High level invalid. 30dB Range Hold. Upper limit [VALUE].
 - 44 High level invalid. 40dB Range Hold. Upper limit [VALUE].
 - 45 High level invalid. 50dB Range Hold. Upper limit [VALUE].
 - 46 High level invalid. Lower limit [VALUE].
 - 47 High level invalid. 0dB Range Hold. Lower limit [VALUE].
 - 48 High level invalid. 10dB Range Hold. Lower limit [VALUE].
 - 49 High level invalid. 20dB Range Hold. Lower limit [VALUE].
 - 50 High level invalid. 30dB Range Hold. Lower limit [VALUE].
 - 51 High level invalid. 40dB Range Hold. Lower limit [VALUE].
 - 52 High level invalid. 50dB Range Hold. Lower limit [VALUE].
 - 53 Low level invalid. Upper limit [VALUE].
 - 54 Low level invalid. 0dB Range Hold. Upper limit [VALUE].
 - 55 Low level invalid. 10dB Range Hold. Upper limit [VALUE].
 - 56 Low level invalid. 20dB Range Hold. Upper limit [VALUE].
 - 57 Low level invalid. 30dB Range Hold. Upper limit [VALUE].
 - 58 Low level invalid. 40dB Range Hold. Upper limit [VALUE].
 - 59 Low level invalid. 50dB Range Hold. Upper limit [VALUE].
 - 60 Low level invalid. Lower limit [VALUE].
 - 62 Low level invalid. 0dB Range Hold. Lower limit [VALUE].
 - 63 Low level invalid. 10dB Range Hold. Lower limit [VALUE].
 - 64 Low level invalid. 20dB Range Hold. Lower limit [VALUE].
 - 65 Low level invalid. 30dB Range Hold. Lower limit [VALUE].
 - 66 Low level invalid. 40dB Range Hold. Lower limit [VALUE].
 - 67 Low level invalid. 50dB Range Hold. Lower limit [VALUE].
 - 68 Output load invalid. Upper limit [VALUE].
 - 69 Output load invalid. Lower limit [VALUE].
 - 70 Duty cycle invalid. Upper limit [VALUE].
 - 71 Duty cycle invalid. Lower limit [VALUE].
 - 72 Duty cycle fixed for frequencies above 25MHz.

-
- 73 Ramp symmetry invalid. Upper limit 100.0%.
 - 74 Ramp symmetry invalid. Lower limit 0.0%.
 - 75 Noise percentage invalid. Upper limit 50%.
 - 76 Noise percentage invalid. Lower limit 0%.
 - 77 Waveform percentage invalid. Upper limit 100%.
 - 78 Waveform percentage invalid. Lower limit 50%.
 - 79 Noise level + waveform level cannot exceed 100%.
 - 80 Noise cannot be added to Square.
 - 81 Noise cannot be added to Pulse.
 - 82 Noise cannot be added to Noise.
 - 83 Frequency invalid for Square. Square frequency upper limit [VALUE].
or Period invalid for Square. Square period lower limit [VALUE].
 - 85 Frequency invalid for Square. Square frequency lower limit [VALUE].
or Period invalid for Square. Square period upper limit [VALUE].
 - 87 Frequency invalid for Ramp. Ramp frequency upper limit [VALUE].
or Period invalid for Ramp. Ramp period lower limit [VALUE].
 - 89 Frequency invalid for Ramp. Ramp frequency lower limit [VALUE].
or Period invalid for Ramp. Ramp period upper limit [VALUE].
 - 91 Frequency invalid for Arb. Arb frequency upper limit [VALUE].
or Period invalid for Arb. Arb period lower limit [VALUE].
 - 93 Frequency invalid for Arb. Arb frequency lower limit [VALUE].
or Period invalid for Arb. Arb period upper limit [VALUE].
 - 95 Cannot add Noise to Square. Turn NoiseAdd off to output Square.
 - 96 Cannot add Noise to Pulse. Turn NoiseAdd off to output Pulse.
 - 97 Cannot add Noise to Noise. Turn NoiseAdd off to output Noise.
 - 98 PWM invalid for Sine. Turn Mod off to output Sine.
 - 99 PWM invalid for Square. Turn Mod off to output Square.
 - 100 PWM invalid for Ramp. Turn Mod off to output Ramp.
 - 101 PWM invalid for Arb. Turn Mod off to output Arb.
 - 102 Hop frequency invalid for Square. Square frequency upper limit [VALUE].
 - 103 Hop frequency invalid for Ramp. Ramp frequency upper limit [VALUE].
 - 104 Hop frequency invalid for Arb. Arb frequency upper limit [VALUE].
 - 105 Deviation invalid for Square. Square Dev+Freq upper limit [VALUE].
 - 106 Deviation invalid for Ramp. Ramp Dev+Freq upper limit [VALUE].
 - 107 Deviation invalid for Arb. Arb Dev+Freq upper limit [VALUE].
 - 108 Only PWM valid for Pulse. Turn Mod off to output Pulse.
 - 109 Modulation invalid for Noise. Turn Mod off to output Noise.

-
- 110 Sweep frequencies invalid for Square. Square frequency upper limit [VALUE].
 - 111 Sweep frequencies invalid for Ramp. Ramp frequency upper limit [VALUE].
 - 112 Sweep frequencies invalid for Arb. Arb frequency upper limit [VALUE].
 - 113 Sweep invalid for Pulse. Turn Sweep off to output Pulse.
 - 114 Sweep invalid for Noise. Turn Sweep off to output Noise.
 - 115 Only Gated Burst is valid for Noise.
 - 116 DC cannot be selected if Mod, Sweep or Burst is on.
 - 117 Frequency invalid. Lower limit [VALUE].
or Period invalid. Upper limit [VALUE].
 - 119 Frequency invalid. Upper limit [VALUE].
or Period invalid. Lower limit [VALUE].
 - 121 Period cannot be less than Delay+Width+Deviation+Rise+Fall.
or Period cannot be less than Delay+Width+Rise+Fall.
 - 123 Period cannot be less than Delay+Width+Deviation+2*Fall.
or Period cannot be less than Delay+Width+2*Fall.
 - 125 Period cannot be less than Delay+Width+Deviation+[MIN WIDTH VALUE].
or Period cannot be less than Delay+Width+[MIN WIDTH VALUE].
 - 127 Width cannot exceed Period-Delay-Deviation-[MIN WIDTH VALUE].
or Width cannot exceed Period-Delay-[MIN WIDTH VALUE].
 - 129 Width-Deviation invalid. Lower limit [MIN WIDTH VALUE].
or Width time invalid. Lower limit [MIN WIDTH VALUE].
 - 131 Width cannot exceed Period-Delay-Deviation-Rise-Fall.
or Width cannot exceed Period-Delay-Rise-Fall.
 - 133 Width cannot exceed Period-Delay-Deviation-2*Fall.
or Width cannot exceed Period-Delay-2*Fall.
 - 135 Width cannot be less than Deviation+Rise+Fall.
or Width cannot be less than Rise+Fall.
 - 137 Width cannot be less than Deviation+2*Rise.
or Width cannot be less than 2*Rise.
 - 139 Delay cannot exceed Period-Width-Deviation-[MIN WIDTH VALUE].
or Delay cannot exceed Period-Width-[MIN WIDTH VALUE].
 - 141 Delay time invalid. Lower limit 0ns.
 - 142 Delay cannot exceed Period-Width-Deviation-Rise-Fall.
or Delay cannot exceed Period-Width-Rise-Fall.
 - 144 Delay cannot exceed Period-Width-Deviation-2*Fall.
or Delay cannot exceed Period-Width-2*Fall.
 - 146 Rise time invalid. Upper limit [VALUE].
 - 147 Rise time invalid. Lower limit [VALUE].
-

-
- 148 Rise+Fall cannot exceed Width-Deviation.
 - or Rise+Fall cannot exceed Width.
 - 150 Rise time cannot exceed Width-Deviation/2.
 - or Rise time cannot exceed Width/2.
 - 152 Rise+Fall cannot exceed Period-Delay-Width-Deviation.
 - or Rise+Fall cannot exceed Period-Delay-Width.
 - 154 Fall time invalid. Upper limit [VALUE].
 - 155 Fall time invalid. Lower limit [VALUE].
 - 156 Fall time cannot exceed Period-Delay-Width-Deviation/2.
 - or Fall time cannot exceed Period-Delay-Width/2.
 - 158 Edge time invalid. Upper limit 40 μ s.
 - 159 Edge time invalid. Lower limit [VALUE].
 - 160 Modulation frequency invalid. Upper limit 20kHz.
 - 161 Modulation frequency invalid. Lower limit 1 μ Hz.
 - 162 Amplitude depth invalid. Upper limit 120%.
 - 163 Amplitude depth invalid. Lower limit 0%.
 - 164 Phase deviation invalid. Upper limit +360 degrees.
 - 165 Phase deviation invalid. Lower limit -360 degrees.
 - 166 Frequency deviation invalid. Freq+Dev upper limit [VALUE].
 - 167 Frequency deviation invalid. Lower limit [VALUE].
 - 168 Frequency deviation cannot exceed carrier frequency.
 - 169 Deviation cannot exceed Period-Delay-Width-[MIN WIDTH VALUE].
 - 171 Deviation cannot exceed Width-[MIN WIDTH VALUE].
 - 172 Deviation invalid. Lower limit 0ns.
 - 173 Deviation cannot exceed Period-Delay-Width-Rise-Fall.
 - 174 Deviation cannot exceed Period-Delay-Width-2*Fall.
 - 175 Deviation cannot exceed Width-Rise-Fall.
 - 176 Deviation cannot exceed Width-2*Rise.
 - 177 Hop frequency invalid. Upper limit [VALUE].
 - 178 Hop frequency invalid. Lower limit [VALUE].
 - 179 FSK rate invalid. Upper limit 100kHz.
 - 180 FSK rate invalid. Lower limit 2mHz.
 - 181 Unable to Modulate Noise.
 - 182 Unable to Modulate DC.
 - 183 Sweep time invalid. Upper limit 500s.
 - 184 Sweep time invalid. Lower limit 1ms.
 - 185 Sweep trigger period invalid. Upper limit 500s.
 - 186 Sweep trigger period invalid. Lower limit 1ms.
-

-
- 187 Stop frequency invalid. Upper limit [VALUE].
 - or Frequency invalid. Centre+Span/2 upper limit [VALUE].
 - 189 Start frequency invalid. Upper limit [VALUE].
 - or Stop frequency invalid. Lower limit [VALUE].
 - 191 Start frequency invalid. Lower limit [VALUE].
 - or Frequency invalid. Centre-Span/2 lower limit [VALUE].
 - 193 Marker frequency invalid. Upper limit [VALUE].
 - 194 Marker frequency invalid. Lower limit [VALUE].
 - 195 Unable to Sweep Noise.
 - 196 Unable to Sweep Pulse.
 - 197 Unable to Sweep DC.
 - 198 Burst count invalid. Upper limit 1048575.
 - 199 Burst count invalid. Lower limit 1.
 - 200 Phase invalid. Upper limit +360 degrees.
 - 201 Phase invalid. Lower limit -360 degrees.
 - 202 Burst trigger period invalid. Upper limit 500s.
 - 203 Burst trigger period invalid. Lower limit 1µs.
 - 204 Unable to Burst DC.
 - 205 Only Gated Burst allowed for Noise.
 - 206 Only Infinite Burst allowed for current frequency.
 - 208 Amplitude value invalid. Upper limit +8191.
 - 209 Amplitude value invalid. Lower limit -8192.
 - 210 Point number invalid. Last defined point [VALUE].
 - 211 Point number invalid. Least defined point 1.
 - 212 Number of points invalid. Upper limit [VALUE].
 - 213 Number of points invalid. Lower limit 1.
 - 214 Arbs cannot be edited if Mod, Sweep or Burst is on.
 - 215 Please specify a filename in Short-FileNameSFN format.
 - 216 Clock source cannot be changed when generator is set as Slave.
 - 217 Generator cannot be Master/Slave when FM/FSK/Sweep/Burst is on.
 - 218 Generator cannot be Master/Slave for Pulse/Noise/DC waveforms.
 - 219 Sync cannot be changed when generator is set as Master.
 - 220 Unable to perform Burst when generator is set as Master/Slave.
 - 221 Unable to perform Sweep when generator is set as Master/Slave.
 - 222 Unable to output Pulse when generator is set as Master/Slave.
 - 223 Unable to output Noise when generator is set as Master/Slave.
 - 224 DC cannot be selected when generator is set as Master/Slave.
 - 225 FM cannot be selected when generator is set as Master/Slave.
-

-
- 226 FSK cannot be selected when generator is set as Master/Slave.
 - 227 Incorrect password. Please try again.
 - 228 Password did not match. Please try again.
 - 229 Unsupported USB device. Device current limit to 500mA.
 - 230 Unsupported USB device. Please insert USB-Flash disk only.
 - 231 Unsupported remote command.
 - 232 Unsupported remote command Parameter.
 - 233 The specified parameter is not valid for this current modulation, sweep or burst function.
 - 234 The specified ARB location is not available.
 - 236 Please insert USB-Flash disk and try again.
 - 237 USB-Flash disk files limit to 1260
 - 238 Please edit different file name as the current file already exist.
 - 239 FATAL ERROR: Invalid waveform location.
 - 240 FATAL ERROR: Invalid setup location.
 - 241 Unsupported waveform file or the file may be corrupted, please wait.
 - 242 Unsupported setup file or the file may be corrupted, please wait.
 - 243 OUTPUT OVERLOAD ERROR. Output turned off for safety.
 - 244 Unsupported command on the Webpage.
 - 245 Unable to Recall instrument setup. The specified location is empty.
 - 246 Test failed at address [VALUE]. Data written [VALUE]. Data read back [VALUE].
 - 247 Modulation is not allowed for NOISE.
 - 248 Only PWM is allowed for Pulse or PWM is allowed only for Pulse

Warning Messages

- 1 Carrier frequency changed to maximum allowed for selected waveform.
or Carrier period changed to minimum allowed for selected waveform.
- 3 Carrier frequency changed to minimum allowed for selected waveform.
or Carrier period changed to maximum allowed for selected waveform.
- 5 Duty cycle has been changed. Upper limit for current frequency is 60%.
- 6 Duty cycle has been changed. Lower limit for current frequency is 40%.
- 7 Duty cycle has been changed. Fixed to 50% for current frequency.
- 8 Current Arb shape ignored. Arb shape is as defined in Tests menu.
- 9 Current Arb shape changed to default Exponential Rise.
- 10 Arb stored at Arb2 will be erased for desired number of points.
- 11 Arb stored at Arb4 will be erased for desired number of points.
- 12 Freq Dev changed to maximum allowed for current frequency setting.
- 13 Freq Dev changed to minimum allowed for current frequency setting.
- 14 Hop frequency changed to maximum allowed for selected waveform.
- 15 Hop frequency changed to minimum allowed for selected waveform.

-
- 16 Deviation changed to maximum allowed for current settings.
 - 17 AM internal waveform shape changed to default Sine.
 - 18 FM internal waveform shape changed to default Sine.
 - 19 PM internal waveform shape changed to default Sine.
 - 20 PWM internal waveform shape changed to default Sine.
 - 21 Current Arb shape changed to default Exp to allow Modulation.
 - 22 Current Arb shape changed to default Exp to allow Sweep.
 - 23 Current Arb shape changed to default Exp to allow Burst.
 - 24 Frequency parameters changed to allow Sweep for current waveform.
 - 25 Marker frequency changed to fall between start/stop frequencies.
 - 26 Burst type has been changed.
 - 27 Burst trigger source changed. Current trigger source is internal.
 - 28 External clock invalid. Generator running on internal clock.
 - 29 External clock detected. Generator running on external clock.
 - 30 Wrong key pressed. Press keys as instructed.
 - 31 Generator is set as Master.
 - 32 Generator is set as Slave.
 - 33 Current Arb shape changed to default Exp to allow phase lock.
 - 34 Current Mod type changed to default AM to allow phase lock.
 - 35 Instrument is not calibrated.
 - 36 Calibration values cleared. Please power-cycle the instrument.
 - 37 USB-Flash disk waveform files limited to 1260.
 - 38 USB-Flash disk setup files limited to 1260.
 - 39 Please press again to overwrite.
 - 40 File was created from 1-CHN-Model. Please press again to copy.
 - 41 File was created from 25MHz-Model. Please press again to copy.
 - 42 File was created from different firmware. Please press again to copy.
 - 43 Arb stored at Arb2 will be erased. Please press EXECUTE to overwrite.
 - 44 Arb stored at Arb4 will be erased. Please press EXECUTE to overwrite.
 - 45 Negative Vpp/Vrms not allowed. Sign has been changed to positive.

Information Messages

- 501 Key test successful.
- 502 New password stored.
- 503 Select a unit to enter value or press Cancel.
- 504 Please reduce the files on USB-Flash disk and try again.
- 505 Test data has been written to RAM.
- 506 RAM test successful.

Appendix 2. Factory Default Settings

Output Configuration	Factory Setting
Function	Sine wave
Frequency	10kHz
Amplitude / Offset	1 Vpp / 0.000 Vdc
Output Units	Vpp
Output Termination	50Ω
Autorange	On
Modulation	Factory Setting
Carrier AM, FM, PM, FSK	10 kHz Sine wave
Carrier PWM	10 kHz Pulse
Mod. Waveform AM	1 kHz Sine wave
Mod. Waveform FM, PM, PWM	1 kHz Sine wave
AM Depth	100%
FM Deviation	5 kHz
PM Deviation	180 degrees
FSK Hop Frequency	100 kHz
FSK Rate	1 kHz
PWM Width Deviation	1 μs
Modulation State	Off
Sweep	Factory Setting
Start / Stop Frequency	10 kHz / 100 kHz
Sweep Time	1 ms
Sweep Mode	Linear
Sweep State	Off
Burst	Factory Setting
Burst Count	1 Cycle
Burst Period	1 ms
Burst Start Phase	0 degrees
Burst State	Off
System-Related Operations	Factory Setting
Power-Down Recall	Disabled
Display Mode	On
Error Queue	Errors are Cleared
Stored States, Stored Arbs	No Change
Output State	Off

Triggering Operations

Trigger Source

Factory Setting

Internal Immediate

Remote Interface Configuration**Factory Setting**

GPIB Address

5

DHCP

On

Auto IP

On

IP Address

192.168.1.100

Subnet Mask

255.255.0.0

Default Gateway

0.0.0.0

DNS Server

0.0.0.0

Host Name

none

Domain Name

*none***Calibration****Factory Setting**

Calibration State

Not protected

Appendix 3. Waveform Manager Plus Version 4 Arbitrary Waveform Creation and Management Software

The Waveform Manager Plus Version 4 program allows construction, editing, exchange, translation and storage of many types of waveform data. It is compatible with many popular DSOs and all TTI waveform generation products.

Waveforms may be generated by equation entry, freehand drawing, combining existing waveforms or any combinations of these methods.

Data upload and download are possible via LAN, USB or GPIB subject to a compatible GPIB card being correctly installed and configured in your PC.

Files can also be uploaded/downloaded to the usb flash drive and the flash drive then used directly with the instrument.

Both upload and download of waveform data are possible.

Text data may be read from the Windows clipboard and used to create a waveform. The text data format is very free and will allow most lists of numbers, with or without intervening text, to be read as waveform data points. Waveform data may also be pasted to the clipboard for insertion into other programs.

Waveform data may also be read from files conforming to the CSV file format.

Waveforms are displayed in fully scaleable windows and may be manipulated graphically. Any number of waveforms in any of the supported types may be displayed simultaneously.

On-line help is available in three ways.

1. The help menu contains a contents option from which you can go to any section of the on-line help file or browse particular areas or the whole file. It is also possible to use the Index and Find operations of the Windows help system to search for items which are not listed directly in the contents section.
2. Some dialog boxes have a Help button which, when clicked, will open the on-line help file at the section containing the description of that dialog box.
3. From most windows/dialogues the F1 key will open the help file at the relevant section.

Waveform Manager Plus allows you to keep waveforms for different projects separate from each other on your hard drive. A project may be placed anywhere, in any directory folder and all waveform files for that project will be stored in a structure below that directory. A project is identified by a user defined name. Each project maintains its own library of expressions.

Maintenance

The Manufacturers or their agents overseas will provide a repair service for any unit developing a fault. Where owners wish to undertake their own maintenance work, this should only be done by skilled personnel in conjunction with the service guide which may be obtained directly from the Manufacturers or their agents overseas.

Cleaning

If the instrument requires cleaning use a cloth that is only lightly dampened with water or a mild detergent.

WARNING! TO AVOID ELECTRIC SHOCK, OR DAMAGE TO THE INSTRUMENT, NEVER ALLOW WATER TO GET INSIDE THE CASE. TO AVOID DAMAGE TO THE CASE NEVER CLEAN WITH SOLVENTS.

Web link

For the latest version of this instruction manual, IVI driver and any applicable firmware updates go to <http://www.tti-test.com/go/tgx>



Thurlby Thandar Instruments Ltd.

Glebe Road • Huntingdon • Cambridgeshire • PE29 7DR • England (United Kingdom)

Telephone: +44 (0)1480 412451 • Fax: +44 (0)1480 450409

International web site: www.tti-test.com • UK web site: www.tti.co.uk

Email: info@tti-test.com